



**ELECTRO-HYDRAULIC
MOBILE COLUMN LIFTS**

HYDROLIFT S4



SERVING THE SHOP® SINCE 1925



INNOVATIVE FEATURES.

Each column has identifying numbering and a led indicator that shows column operation in real time. All information on the column's state can be checked directly on the App.

FIRST ON THE MARKET.

App to set the lift and the layout of the columns. The configuration system for columns by App ensures enhanced safety, speed and simplicity in operations.

TOTALLY SAFE.

Mechanical Safety Latch System with reduced pitch and increased contact width for greater safety during lifting procedures and to improve parking functions.

ELECTRO-HYDRAULIC DEVICE

that interrupts descent movement if an obstacle is under a platform.

EXTENDED WIDTH compared to the previous version.

SAFETY VALVES to protect against overloading and rupture of hydraulic pipes.





Lift Operation is managed using a **CONTROL PUSH-BUTTON PANEL** on each column.



DESCENT SPEED control valve.



IP 54 PROTECTION rated electrical system. Low voltage control and safety circuit.

COMPACT AND SOLID DESIGN.

Powerful hydraulic unit for effortless lifting, paired with all day battery for seamless work.



HYDRAULIC TROLLEY

for improved column mobility during handling, engagement under the vehicle and parking.



FORKLIFT POCKETS

to facilitate lifting with forklifts.

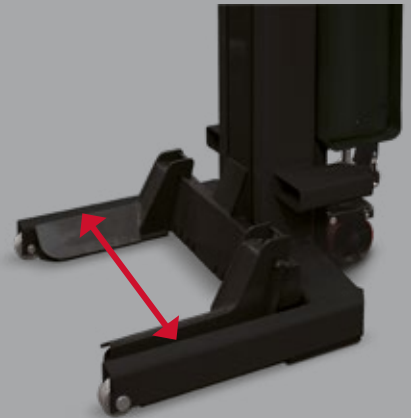

ADJUSTABLE FORKS

to operate on light and heavy commercial vehicles with wheels of different dimensions.



CONFIGURATION OF THE AVAILABLE COLUMNS

and creation of separate groups in case the vehicle requires different lift heights.

Software updates over-the-air. Available for Android and iOS.

REAL-TIME STATUS.

Mobile column waiting for connection

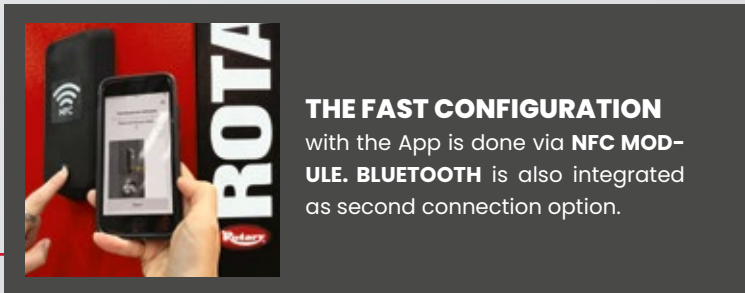

THE FAST CONFIGURATION with the App is done via **NFC MODULE**. **BLUETOOTH** is also integrated as second connection option.

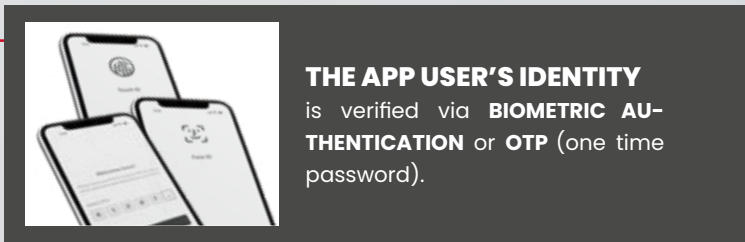

THE APP USER'S IDENTITY is verified via **BIOMETRIC AUTHENTICATION** or **OTP** (one time password).

Mobile column showing error



SIMPLIFIED TROUBLESHOOTING.

Identification of column error status and direct link to manual.

Mobile column paired and ready to use

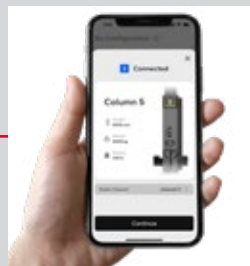

ACCESSORIES



119777

Traverse load capacity 16.4 t.



120260

Traverse king pin adapter, load capacity 16.4 t.



122911

Front and rear adapters for lifting various tractors and agricultural vehicles, load capacity 16.4 t.



127615

Trolley for the tractor adapter set.



M75-JCYB-KIT

Wheel fork extension for lifting motorhomes, 150 mm, load capacity reduced to 4 t.

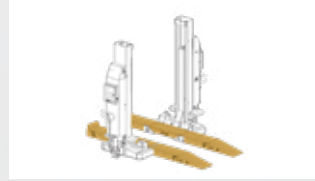

M140124BG

Drive-on ramp kit for forklift trucks, accessible from one side.

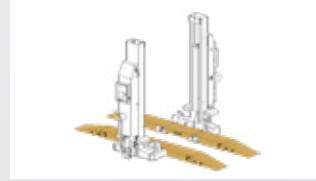

M140127BG

Drive-on ramp kit for forklift trucks, accessible from one side.

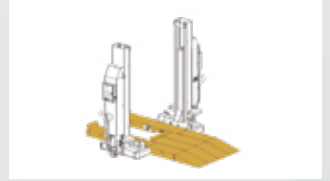

M140153BG

Drive-on ramp kit for three-wheel forklift, accessible from one side.



M110175BG

Trolley for drive-on kit for forklift trucks.



S260A1

Support Trestle ST-7.5-M (safety stand), load capacity 7.5 t.



S270A1

Support Trestle ST-100-M (safety stand), load capacity 10 t.



S270A2

Support Trestle ST-100-S (safety stand), load capacity 10 t.



VSG.MCHYD.903051

Mobile electronic control device.



VSG.MCHYD.903082

Rainproof protective cover for 6.5 - 7.5 t hydraulic mobile columns



VSG.MCHYD.903129

Rainproof protective cover for 8.5 t hydraulic mobile columns.



VSG.MCHYD.903075

LED Lighting kit.

TECHNICAL DATA

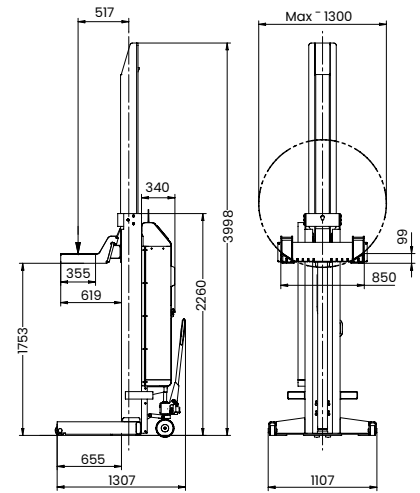

	HydroLift S4 2-6.5	HydroLift S4 4-6.5	HydroLift S4 6-6.5	HydroLift S4 8-6.5	HydroLift S4 2-7.5	HydroLift S4 4-7.5	HydroLift S4 6-7.5	HydroLift S4 8-7.5
	ROT. HYD65.192332	ROT. HYD65.192301	ROT. HYD65.192318	ROT. HYD65.192325	ROT. HYD75.197795	ROT. HYD75.197764	ROT. HYD75.197771	ROT. HYD75.197788
Capacity	13000 kg	26000 kg	39000 kg	52000 kg	15000 kg	30000 kg	45000 kg	60000 kg
Lifting capacity per lifting unit	6500 kg	6500 kg	6500 kg	6500 kg	7500 kg	7500 kg	7500 kg	7500 kg
Communication of columns	wireless							
Number of lifting units	2	4	6	8	2	4	6	8
Stroke	1753 mm							
Lifting time loaded	65 s							
Lowering time loaded	54 s							
Lift cycles fully loaded	14							
Min. wheel diameter	570 mm							
Max. wheel diameter	1300 mm							
Driving power per cylinder unit	3 kW							
Weight per column	640 kg							
Surface coating	powder							
Power supply	230 V 50 - 60 Hz							
Width	1107 mm							
Depth	1307 mm							
Height	2260 mm							
Total weight	1280 kg	2560 kg	3840 kg	5120 kg	1280 kg	2560 kg	3840 kg	5120 kg

TECHNICAL DATA

	HydroLift S4 2-8.5	HydroLift S4 4-8.5	HydroLift S4 6-8.5	HydroLift S4 8-8.5
	ROT.HYD85.192417	ROT.HYD85.192387	ROT.HYD85.192394	ROT.HYD85.192400
Capacity	17000 kg	34000 kg	51000 kg	68000 kg
Lifting capacity per lifting unit	8500 kg			
Communication of columns	wireless			
Number of lifting units	2	4	6	8
Stroke	1753 mm			
Lifting time loaded	78 s			
Lowering time loaded	54 s			
Lift cycles fully loaded	14			
Min. wheel diameter	570 mm			
Max. wheel diameter	1300 mm			
Driving power per cylinder unit	3 kW			
Weight per column	740 kg			
Surface coating	powder			
Power supply	230 V 50 - 60 Hz			
Width	1167 mm			
Depth	1285 mm			
Height	2590 mm			
Total weight	1480 kg	2960 kg	4440 kg	5920 kg



GERMANY **BlitzRotary GmbH** Hüfingener Straße 55 | 78199 Brünlingen | +49 771 9233 0
 ITALY **Vehicle Service Group Italy S.r.l.** Via F. Brunelleschi 9 | 44020 Ostellato FE | +39 051 6781511
 FRANCE **RAV France SARL** 4, Rue De Longue Raie, ZAC de la Tremblaie | 91220 Le Plessis P^ortz | +33 1 60 86 88 16
 UK **Vehicle Service Group UK Ltd** 3 Fourth Avenue, Bluebridge Industrial EST | Halstead, Essex, CO9 2SY | +44 1787 477711

a company

info.emea@rotarysolutions.com

ROTARYsolutions.eu