

Alle Maße in Millimeter
all dimensions in millimeter
Maß- und Konstruktionsänderungen vorbehalten!
subject to alterations!

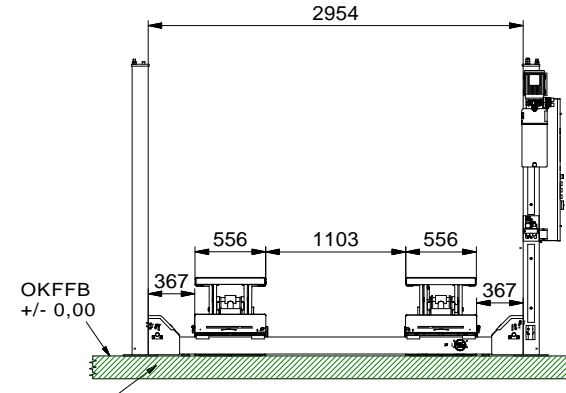

Betonqualität
quality of concrete
min.C20/25
normal bewehrt
normal armoring

Hinweis: elektrische Anlagen und Betriebsmittel dürfen nur von Elektrofachkräften oder von elektrotechnisch unterwiesenen Personen unter Leitung und Aufsicht von Elektrofachkräften errichtet, verändert, instand gesetzt und geprüft werden.

Bauseits an der Bedieneinheit bereitstellen:
Netzanschluss: 3PH,N+PE,400V,50Hz
Absicherung: 16 Ampere träge
Kabellänge: ca. 2m, 5x2,5mm²
Druckluft R1/4" oder Schlauch DN8, 6-8 bar

Note: Final electrical connection of the lift must be made by a qualified electrician."

Prepared by customer at the main operating unit:
power supply: 3PH,N+PE,400V,50Hz
fuse: 16 Ampere, time lag
cable diameter: 5x 2,5m²
cable length: approx. 2 m
optional: air pressure 1/4" or hose 8 mm, 6-8 bar

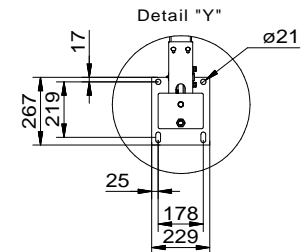

Wir weisen in unseren Plänen auf die Mindestanforderung des Fundamentes hin, jedoch der Zustand der örtlichen Gegebenheiten (z.B. Untergrund, Ausführung etc.) obliegt nicht unserer Verantwortung. Die Ausbildung der Einbausituation muss vom planenden Architekten bzw. Statiker im speziellen Fall individuell spezifiziert werden.

We point out the minimum requirement of the foundation in our plans. The condition of the local realities for example: the ground under the foundation) does not lie in our responsibility. The execution of the installation situation must be individually specified by the planning architect or by the engineer engaged in statically calculations in the special case.

				THIRD ANGLE PROJECTION	SM40LT-47N Schienenlänge 4700mm platform length
				DO NOT SCALE DRAWING	
				UNLESS OTHERWISE NOTED: ANGULAR DIMENSIONS: +/- 1° OTHER DIMENSIONS: +/- 0.8mm (<305mm) +/- 1.6mm (>or= 305mm)	UNLESS OTHERWISE SPECIFIED: 0.8mm MIN. CORNER BREAK REMOVE ALL BURRS
				NOTES:	
				Tragfähigkeit/capacity: max.4000kg Radfreiheber/wheel free lift: 3000 kg	
REV	CO NUM	DATE	BY	The design and detail illustrated in this drawing is the property of Vehicle Service Group. It is being loaned with the expressed condition that it will not be duplicated or used except by permission and is subject to return upon request.	
				DOWN MG DATE 29-03-17 SHEET	DRAWING NUMBER 4-Post-Lift_Da_SM40LT-47N_8655