



DS35EX
Scissor Lift
3500KG
(100Series)



Installer: Please return this booklet to literature package and give to lift owner/operator.

EG-Konformitätserklärung
EC Declaration of Conformity

im Sinne der EG-Richtlinie 2006/42/EG über Maschinen (Anhang II A)
according to EC directive 2006/42/EC on machinery (Annex II A)

Name und Anschrift des Herstellers
Name and address of the manufacturer:

Rotary Lift Consolidated (Haimen) Co., Ltd.
No. 1388 East Xiushan Road
Haimen, Jiangsu Province, China

**Name und Anschrift seines in der EU
niedergelassenen Bevollmächtigten**
his authorised representative in EU

BlitzRotary GmbH
Hüfinger Str.55
78199 Bräunlingen, Germany

Diese Erklärung bezieht sich nur auf die Maschine in dem Zustand, in dem sie in Verkehr gebracht wurde; vom Endnutzer nachträglich angebrachte Teile und/oder nachträglich vorgenommene Eingriffe bleiben unberücksichtigt. Die Erklärung verliert ihre Gültigkeit, wenn das Produkt ohne Zustimmung umgebaut oder verändert wird.

This declaration relates exclusively to the machinery in the state in which it was placed on the market, and excludes components which are added and/or operations carried out subsequently by the final user. The declaration is no more valid, if the product is modified without agreement.

Hiermit erklären wir, dass die nachstehend beschriebene Maschine

Herewith we declare, that the machinery described below

Produktbezeichnung / product denomination:

Serien- / Typenbezeichnung / model / type

Scherenhebebühne/ Scissor lift

DS35EX

Tragfähigkeit 3500 kg / capacity 3500 kg

Maschinen-/Seriennummer / machinery / serial number:

Baujahr / Year of manufacture:

20.....

allen einschlägigen Bestimmungen der Maschinenrichtlinie 2006/42/EG entspricht.

Die Maschine entspricht zusätzlich den Bestimmungen der Richtlinien 2014/30/EU über elektromagnetische Verträglichkeit und 2014/35/EU über elektrische Betriebsmittel (*Schutzziele wurden gemäß Anhang I, Nr. 1.5.1 der Maschinenrichtlinie 2006/42/EG eingehalten*).

is complying with all essential requirements of the Machinery Directive 2006/42/EC.

In addition the partly completed machinery is in conformity with the EC Directives 2014/30/EC relating to electromagnetic compatibility and 2014/35/EC relating to electrical equipment (Protection objectives have been met in accordance with Annex I No. 1.5.1 of the Machinery Directive 2006/42/EC).

Angewandte harmonisierte Normen / Harmonised Standards used

DIN EN 1493:2011-02	Fahrzeug-Hebebühnen / Vehicle lifts
DIN EN ISO 12100:2011-03	Sicherheit von Maschinen - Grundbegriffe / Safety of Machinery- Basic concepts
EN 60204:2019-06	Elektrische Ausrüstung von Maschinen / Electrical equipment of machines
EN ISO 13850:2015	Sicherheit von Maschinen-Not-Halt / Safety of machinery – Emergency stop

Alle Hebebühnen des Typs von oben genanntem Hersteller gefertigt nach dem geprüften Baumauster / All lifts of the same model manufactured by the named company in accordance with the tested type of lift.

Certificate Number: CE-C-0930-15-98-02-5A

**Approval Body: CCQS UK Ltd., Level 7, Westgate House, Westgate Road,
London W5 1YY UK
Notified Body No. 1105**

Ort/Place: Bräunlingen
Datum/Date: 13.10.2021



Simone Ferrari
Geschäftsführer / Managing Director

Table of Contents

1. Introduction	5	5.2 Troubleshooting by authorized maintenance contractors	20
1.1 About this operating manual	5	6. Authorized lowering	23
1.2 Warning and information symbols	5	7. Technical data	24
1.3 Intended use	7	8. Cleaning	28
1.4 Incorrect use, incorrect behavior	7	9. Maintenance and repair	28
1.5 Internal accident, health and safety, and environmental information	7	9.1 Qualification of maintenance and repair staff	28
2. Safety	8	9.2 Maintenance and repair safety regulations	28
2.1 Operators	8	9.3 Maintenance work	29
2.2 Basic safety requirements	8	9.4 Approved hydraulic oils	31
2.3 Permitted axle loads and weight distribution	8	9.5 Check, refill, change the hydraulic oil	31
2.4 Ban on unauthorized modifications or alterations	9	9.6 Repair work (Repairs)	32
2.5 Experts, competent persons	9	10. Transport, Storage	33
2.6 Maintenance contractors, installation staff	10	10.1 Transport	34
2.7 Safety inspections by competent persons	10	10.2 Offloading.....	34
2.8 Obligations of the plant operator	11	10.3 Storage	34
3. The Scissor Lift	12	11. Assembly	35
3.1 Overview of parts	12	11.1 Assembly safety instructions	35
3.2 General workflow	13	11.2 Site specifications	35
3.3 Work area, danger zones	13	11.3 Installation preparations	35
3.4 Safety mechanisms	14	11.4 General lift location.....	36
3.5 Control unit	16	11.5 Control cabinet connections.....	36
4. Operation	17	11.6 Oil filling bleeding hose connection.....	39
4.1 Before loading	17	11.7 Final positing of platforms	40
4.2 Loading	17	11.8 Anchoring.....	41
4.3 To raise lift.....	18	11.9 Hose covers and anchoring(surface mounted).....	42
4.4 While using lift	19	11.10 Flush mount pit.....	42
4.5 Before lowering lift.....	19	11.11 Adjust cushion device.....	43
4.6 To lower lift.....	19	12. Commissioning	44
4.7 Unloading	19	12.1 Check the operation.....	44
4.8 Power off	19	12.2 Test the hydraulic system.. ..	44
5. Problems, causes, actions	19		
5.1 Troubleshooting by the operator	19		

13. Disassembly44

14. Disposal44

14.1 Environmental procedures for disposal44

14.2 Packaging45

14.3 Oils, grease, and other chemical substances45

14.4 Metals / Electronic waste45

ANNEX

- DS35EX:
Wiring diagrams,
Hydraulic circuit diagram, spare parts lists

- Protocol of installation

- Completion certificate

- Maintenance schedule: Instructions for conducting
visual inspections and function testing

- Inspection log

- Test report

1. Introduction

1.1 About this operating manual

The scissor lift conforms to state of the art technology and complies with the applicable occupational health & safety and accident prevention regulations. Notwithstanding, improper use or use other than that which is intended may result in a risk of fatal or physical injury to the user or third parties and may also result in damage to property.

It is therefore imperative that the relevant people carefully read and understand this operating manual. Read the instructions carefully to prevent incorrect use, potential hazards and damage. The scissor lift should always be operated according to regulations.

Please note the following:

- The operating manual must be kept near the lift and be easily accessible for all users.
- This operating manual provides information on the scissor lift DS35EX.
- **Make sure that you have read and understood Chapter 2, Safety and also the operating instructions supplied with the machine.**
- We assume no liability for damage and operational breakdowns which may occur as a result of non-compliance with the instructions contained within this operating manual.
- Installation and commissioning of the lifts is described in detail in Chapters 11 to 13. Installation may only be carried out by authorized installation specialists and qualified electricians.
- If you should run into difficulties please contact a specialist, our customer service or spare parts department or one of our representatives.
- Illustrations may differ from the supplied version of the machine. Functions or processes to be carried out remain the same.

Disclaimer:

We assume no responsibility for printing errors, mistakes and technical changes. The brands and trademarks mentioned in this document refer to their owners or the products thereof.

1.2. Warning and information symbols

1.2.1 Symbols in this documentation

Warnings are identified by the following symbols, depending on the hazard classification.

Be especially aware of safety and hazards when working in situations identified by warning symbols.

Comply with the occupational health & safety and accident prevention regulations which are applicable in your country.



DANGER

Risk of death or injury

Direct threat to life and health of people. Non-compliance may lead to death or serious injury.



WARNING

Risk of death or injury

Potential risk to life and health of people. Non-compliance may lead to serious or critical injury.



CAUTION

Risk of injury

Potentially hazardous situation. Non-compliance may lead to minor or moderate injury.

ATTENTION

Damage to property

Potentially hazardous situation. Non-compliance may lead to damage to property.

Other Symbols



INFO symbol

Useful information and Tips.



Bullet point:

For lists with key information on the respective subject.



Handling instructions:

Carry out the detailed steps in sequence.



Handling instructions, warning

Carry out the detailed steps in sequence.

1.2.2 On the product



Observe all warning notices on products and ensure they remain legible.

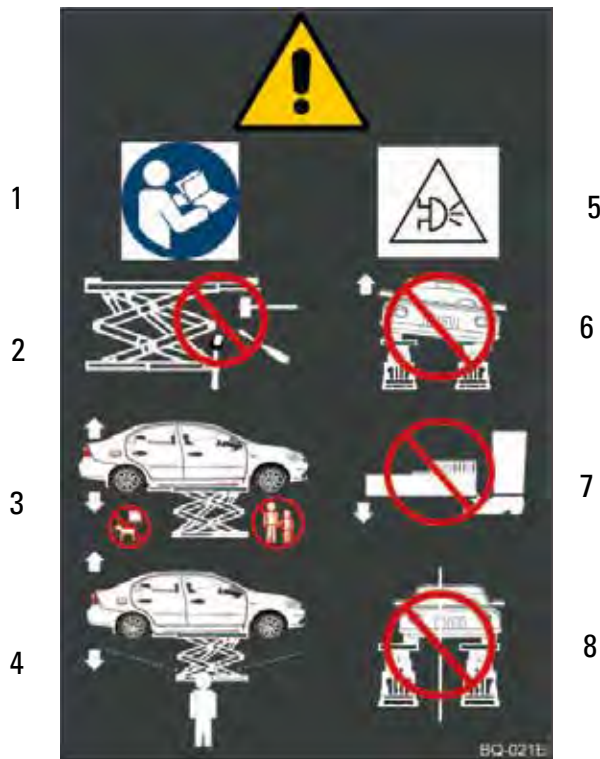

Warning sticker on control cabinet.

1. Read original operating instructions.
2. Never place any objects on the lifting platform.
3. Keep people and animals away from lifting platform.
4. Watch vehicle when raising and lowering.
5. Heed acoustic warning signals from signal generator
6. One-side, one end, one corner raising of vehicle prohibited.
7. Risk of crushing feet on lowering.
8. Vehicle off the platform center prohibited.

Operating instructions in brief

Principali raccomandazioni	Instrucciones Breves	Kurz-Betriebsanleitung	Brief Operating Instructions	Instructions en bref
Solo il personale qualificato è autorizzato ad operare ed utilizzare.	Sólo el personal cualificado está autorizado a manipular el elevador.	Es dürfen nur qualifizierte Personen mit der Bedienung der Hebebühne beauftragt werden.	Only qualified personnel shall be allowed to operate the lift.	Seulement le personnel qualifié est autorisé à travailler sur le pont élévateur.
È obbligatorio per gli operatori leggere le regole di utilizzo e le istruzioni di lavoro e gli avvisi di sicurezza mediante il manuale. L'utente è responsabile secondo quanto indicato nella capacità e le indicazioni del manuale di istruzioni.	Es obligatorio que los operadores respetar las reglas de uso y seguridad a bordo, así como mediante mediante el manual. Utilizar el elevador estrictamente según las aplicaciones e indicaciones del manual de instrucciones.	Der Bediener ist verpflichtet, die Umgebungsanweisungen und Anfahrungsanweisungen zu lesen.	It is obligatory for workers to read health and safety work regulations and related safety notices.	Les opérateurs sont obligés à s'en tenir aux règles sur le pont et la sécurité du travail et les avertissements de sécurité du manuel.
È assolutamente vietato superare la capacità massima del sollevatore.	No superar la capacidad máxima del elevador.	Es ist verboten die Nennlastfähigkeit der Hebebühne zu überschreiten.	Never exceed the maximum lifting capacity when using the lift.	Il est formellement déconseillé de dépasser la capacité maximale du pont élévateur.
È assolutamente vietato la manipolazione o la rimozione dei dispositivi di sicurezza.	Los dispositivos de seguridad nunca pueden ser cambiados, retirados, o quitados.	Die Sicherheitsvorrichtungen dürfen nicht manipuliert, außer Funktion gesetzt oder gar entfernt werden.	The safety devices must not be manipulated, made inoperative or removed.	Il est interdit de manipuler les dispositifs de sécurité.
Controllare la potenza e il veicolo durante la fase di salita e discesa.	Observar las plataformas y el vehículo durante el proceso de subida y bajada.	Beim Heben und Absenken muß die Hebebühne und das Lastfahrzeug beobachtet werden.	Observe lift platform and vehicle during lifting and lowering.	Observer les temps et la puissance lors de la monté/descente du pont élévateur.
L'operatore deve assicurarsi che tutte le Viti di sicurezza siano sempre pronte di sempre al livello o discese.	Cuando subiendo y bajando el elevador, el operador debe asegurarse que no hay pernos en las plataformas o el vehículo, y que están bien sujetos en el vehículo.	Beim Heben und Senken dürfen sich keine Personen auf oder unter der Hebebühne bzw. im Fahrzeug befinden, sowie keine Objekte auf Plattformen vorhanden sein.	During lifting and lowering no persons should stay on, under the lift platform or in the vehicle. No should anyone work on the vehicle.	Lors de la monté/descente du pont élévateur, l'opérateur est obligé à s'assurer que la zone dangereuse est déconseillée.
È vietato camminare sulle pedane del sollevatore.	Es prohibido que ande en el vehículo o las plataformas.	Hochfahren am Lastfahrzeugverstell oder an der Last-Mitwerkzeug.	Climbing on the vehicle or platform of the lift is forbidden.	No pas se placer ou grimper sur les rampes pendant que le pont est levé.
Non tenere oggetti o animali appoggiati nella pedana o sotto di esse che possono interferire la discesa completa del sollevatore.	No objetos o animales sobre o debajo de la plataforma que puedan interferir el descenso completo del elevador.	Keine Personen dürfen beim Herabfahren Gegenstände des Lastfahrzeugverstell daran hängen, in die untere Endstellung zu gelangen.	Carried objects (e.g. tools) must not be left on or under the platform which would interfere with the lowering and operation of the lift.	No pas laisser objets ou animaux sur ou sous la rampe afin de ne pas gêner le descente complète du pont élévateur.
In caso di comportamento anomalo del ponte, fermare o chiudere l'alimentazione elettrica del sollevatore. È vietato della funzione del sollevatore il completarsi il processo di salita.	Si tiene un problema, pare el elevador y cierre el sector control y eléctrico. Solo personal de servicio técnico con alta grado de cualificación debería operar en marcha el elevador.	Bei Störungen der Hebebühne stoppen, den Hauptstrom sofort ausschalten und abschließen. Die Hebebühne darf nur von einem Sachkundigen (Beruflich und weiter in Ausbildung) paratiert werden.	In case of trouble turn the main switch off and lock it. Stoppage of the lift and resulting lift operation must always be carried out by authorized personnel.	Arrêter le pont en cas de fonctionnement anormal. Fermer le secteur "control" et le secteur "électrique". Le fonctionnement est du domaine réservé au personnel qualifié.
Prima di ogni spostarsi o manomissione del sollevatore, disconnettere dalla rete elettrica principale mediante l'interruttore di emergenza in servizio.	Antes de cualquier reparación o mantenimiento del elevador, desconectarlo de la eléctrica principal, y solo puede estar conectado de personal cualificado.	Vor Reparatur und Wartungsarbeiten in die Hebebühne vom Stromnetz zu trennen und gegen unzulässige Eingriffe von nicht fachkundigen Personal zu sichern.	Prior to repair or maintenance disconnect the lift from the main power supply. It should only be turned on by authorized personnel.	Avant chaque remise en état ou entretien, il faut déconnecter le pont élévateur du réseau de courant principal et affiler l'interrupteur par personnel qualifié.
Prendere la massima attenzione a tutte le indicazioni del manuale di istruzioni.	Prender atención a todas las indicaciones en el manual de instrucciones.	Die schriftliche Betriebsanleitung ist zu beachten.	Read and follow all instructions in the instruction/operation manual.	Prendre attention particulière à toutes les indications du mode d'emploi.

These instructions contain information on operation of the control cabinet.



1. Keep feet away from lifting platform whilst lowering.
2. Ramp support 100% engaged when load on the ramp.
3. Keep hands away from scissors of pinch points when lift is moving.

1.3 Intended use

The scissor lift may only be used:

- In indoor areas for lifting unoccupied motor vehicles.
- For lifting vehicles with a max. load capacity of 3500kg
- If the weight is distributed correctly. By default, the load should be centered in the direction of motion. If the main load (e.g. engine) is however at the front or the back, the following applies:
 - at front max. 3/5,
 - at back 2/5 of load or vice versa.
- With correctly aligned, adjustable runways. The vehicle must be approximately centered on the two platforms.
- In accordance with the technical data in Chapter 7, in technically sound condition.

1.4 Incorrect use, incorrect behavior

Incorrect behavior presents a residual risk to the life and health of the people working in the lift area.

The manufacturer assumes no liability for damage resulting from use other than the intended purpose and from incorrect behavior.

The following is prohibited:

- Climbing onto or riding on the scissor lift or the load.
- Lifting when there are people in the vehicle.
- Lifting/lowering when people or animals are in the danger zone, in particular below the lift.
- Jerky lifting or lowering. Do not cause the lift to vibrate.
- Throwing objects onto or under the lift.
- Lifting a vehicle at the incorrect pick-up points .
- Lifting a load on only one platform of the lift.
- Lifting loads not listed in Chapter 1.3.
- Lifting vehicles containing hazardous goods.
- Operating outdoors or in workshops at risk from fire or explosion.

- Washing cars on the scissor lift.
- Modifications of any kind.

1.5 Internal accident, health and safety, and environmental information

This operating manual does not include the operating instructions which need to be drafted by the user of the scissor lift.

The internal operating instructions regulate actions within the company for the prevention of accidents, and risks to health & safety and the environment.

These also include actions in the case of an emergency, first aid measures etc.

2.Safety

2.1 Operators

The scissor lift may only be operated without supervision by persons who:

- Are 18 years old and above.
- Are familiar with the basic regulations on health & safety and accident prevention.
- Have been trained to handle and operate the scissor lift.
- Have proven their ability to do so to the company.
- Have been expressly appointed in writing to operate the lift.
- Have read and understood the operating manual.

2.2 Basic safety requirements

- Only operate the scissor lift after a specialist has certified in the inspection log that it has been correctly set up.
- Always follow the operating instructions (labels on the scissor lift).
- If several people work on the scissor lift, a supervisor must be appointed by the company.
- The scissor lift may only be operated in technically sound condition with regard to safety and with all safety mechanisms in place.
- The control box or control unit may only be opened by a qualified electrician.
- Safety inspections must be conducted regularly, at least once annually.
- If signs of a defect appear, immediately shut down the scissor lift, inform a supervisor and contact the customer service if necessary.
- Keep the work area clean and free of oil, grease, and contamination.
- Before lifting/lowering, check that the acoustic alarm (buzzer) works.
- There must be no obstacles in the path of the scissor lift .
- Always monitor the load carefully when lifting and lowering.
- Always stop the vehicles safely, centered on the platforms.
- Always lift the vehicle on the pick-up points approved by the vehicle manufacturer. Lift it for a short distance and check that the pick-up points are secure. Only then can the vehicle be moved to the required height.
- Take steps against traffic in the area of the scissor lift. Do not park other vehicles in the danger zone.

- Do not load lifts beyond the permitted capacity, comply with the permitted axle loads and load distribution in accordance with Chapter 2.3.
- When disassembling or fitting heavy vehicle parts, watch out for dangerous shifts in the weight balance, in particular when the vehicle is supported by lifting table. Secure the vehicle beforehand.
- Always fully lower, switch off and secure scissor lift to prevent unauthorized use after completion of work (turn main switch to "OFF" and lock).
- Follow the maintenance and service schedule, record performance of maintenance and servicing (Chapter 9).
- Installation, maintenance and servicing may only be carried out by authorized specialists (maintenance contractors) (Chapter 9).
- Only qualified electricians may work on the electrics.
- Only trained people with knowledge of hydraulics/ pneumatics may work on hydraulic or pneumatic equipment.
- Appropriate personal protective equipment must be worn when working in the area of the lift in accordance with the applicable health & safety and accident prevention regulations. For example, protective gloves, protective goggles, safety shoes.
- Only original spare parts from the manufacturer may be used.
- The lift must be inspected by a specialist after repairing any supporting parts.

2.3 Permitted axle loads and weight distribution

Before lifting the vehicle, you must ensure that the weight distribution is correct.

When the weight distribution is correct (default position in direction of motion) the main load is located at the front (e. g. engine).



Risk of injury through toppling of the vehicle when incorrectly loaded.

WARNING

- ➔ Comply with the permitted load capacity as in Fig. 1 and 2.
- ➔ Comply with the permitted weight distribution as in Fig. 1 and 2.
- ➔ Comply with the approved distances between pick-up points as in Fig. 3.

Figure 1&2:

Load capacity 3500kg

front max. 3/5:F1: 2100 kg

back max.2/5:F2: 1400 kg

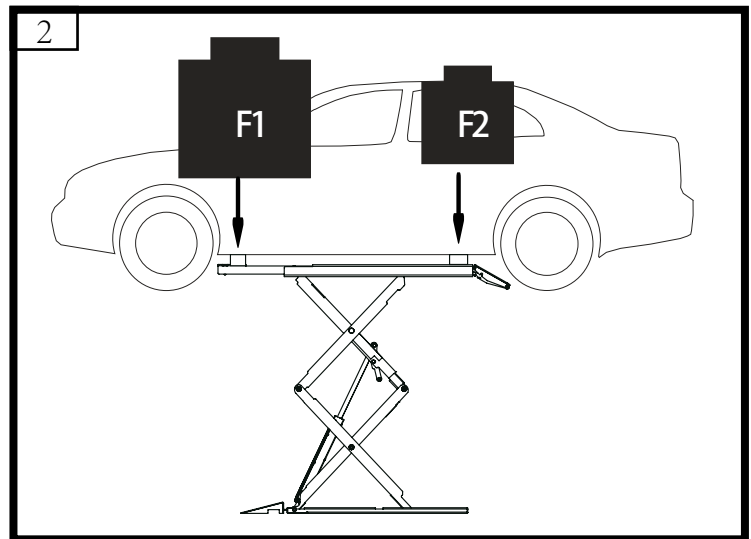
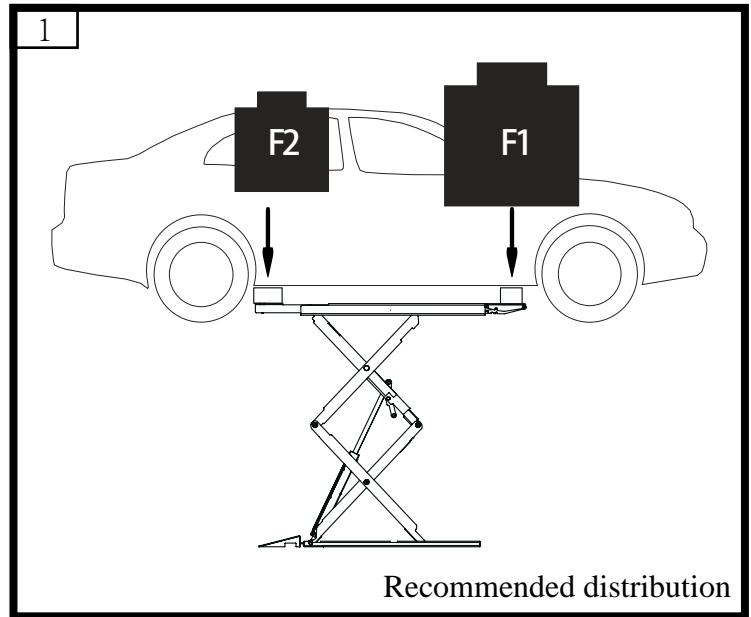

2.4 Ban on unauthorized modifications or alterations

- Unauthorized modifications and alterations to the scissor lift are not permitted for safety reasons.
- The operating permit shall also be deemed null and void.
- The Declaration of Conformity also becomes null and void.

2.5 Experts, competent persons

The scissor lift must be inspected after commissioning and at regular intervals (after max. one year), as well as after design modifications or repair of supporting parts. **Inspections may be carried out by the following people:**

Certified expert

These are people who have specialist knowledge in the field of lifts based on their professional training and experience.

Experts should be able to inspect lifts and make an expert assessment thereof.

TÜV experts, specialist engineers from the manufacturer or self-employed specialist engineers can be used for inspections.

Competent persons

These are people who have adequate knowledge in the field of lifts based on their professional training and experience

They are sufficiently familiar with health & safety and accident prevention regulations as well as with lift technology in order to be able to assess the occupational health & safety compliance of lifts.

2.6 Maintenance contractors, installation staff

Maintenance, servicing and installation work may only be done by companies or specialists authorized by the manufacturer.

These people trained in the field of lifts are competent persons, who are trained for maintenance as well as repair work.

A competent person is a person who has adequate knowledge based on his professional training and experience and is also familiar with key regulations so that he:

- Can assess the work assigned to him,
- Can recognize potential risks,
- Can take actions required to eliminate the risk,
- And has the required knowledge of repair and fitment.

The specialist knowledge of a competent person must enable him to be in a position to

- Read and fully understand circuit diagrams,
- Fully understand the context with particular regard to any installed safety equipment.
- Possess knowledge of the function and design of system components.

Simple faults on the post lift may be rectified by operating staff.

In the event of a more serious fault, contact an authorized maintenance contractor.

2.7 Safety inspections by competent persons

Safety inspections must be carried out to guarantee the safety of lifts.

Safety inspections should be carried out in the following cases:

- Before initial operation, after initial installation. Use the form "Initial safety inspection before installation".
- After initial operation at regular intervals, but at least once a year. Use the form "Regular Safety Inspection".
- After any design modification to parts of the lift. Use the form "Unscheduled Safety Inspection".



The initial safety inspection as well as the safety inspections must be carried out by a **competent person**. We recommend that you also perform maintenance in the course of the inspection.



Unscheduled safety inspections and special maintenance work are required in the event of design modifications to the lift (fitting additional parts). The safety inspection must be carried out by a **competent person**.



Use the form supplied in the Annex containing lists for carrying out safety inspections. Please use the relevant form and staple it to the manual after completion.

2.8 Obligations of the plant operator

Operation of lifting platforms

In Germany, the use of lifting platforms is governed by the mandatory "Employers' liability insurance association regulations on health and work safety as defined in DGUV-100-500 (before BGR 500) Section 2.10". In all other countries, the applicable national regulations, laws and directives must be observed.

Checking of lifting platforms

Checks are to be based on the following directives and regulations:

- Basic principles for testing lifting platforms (DGUV-308-002 before BGG 945)
- The basic health and safety requirements stipulated in the directive 2006/42/EC
- Harmonized European standards
- The generally acknowledged rules of engineering
- The directive on the use of equipment 89/655/EEC and changes with DIRECTIVE 95/63/EC.
- The applicable accident prevention regulations

The checks are to be organized by the user of the lifting platform. The user is responsible for appointing an expert or qualified person to perform checking. It must be ensured that the person chosen satisfies the requirements of BGG 945 as per Section 3.



The user bears special responsibility if employees of the company are appointed as experts or qualified persons.

Scope of checking

Regular checking essentially involves performing a visual inspection and a functional test. This includes checking the condition of the components and equipment, checking that the safety systems are complete and functioning properly and that the inspection log book is completely filled in.

The scope of exceptional checking depends on the nature and extent of any structural modification or repair work.

Regular checking

After initial commissioning, lifting platforms are to be checked by a **qualified person** at intervals of not longer than one year.

A qualified person is somebody with the training and experience required to possess sufficient knowledge of lifting platforms and who is sufficiently familiar with the pertinent national regulations, accident prevention regulations and generally acknowledged rules of engineering (e.g. BG rules, DIN Standards, VDE provisions, the technical regulations of other European Union member states or other parties to the agreement in the European economic area) to be able to assess the safe operating condition of lifting platforms.

Exceptional checking

Lifting platforms with a lift height of more than 2 meters and lifting platforms intended for use with people standing under the loadbearing elements or the load are to be checked by an expert prior to re-use following structural modifications and major repairs to loadbearing components.

An expert is somebody with the training and experience required to possess specialist knowledge of lifting platforms and who is sufficiently familiar with the pertinent national work safety regulations, accident prevention regulations and generally acknowledged rules of engineering (e.g. BG rules, DIN Standards, VDE provisions, the technical regulations of other European Union member states or other parties to the agreement on the European economic area) to be able to check and give an expert opinion on lifting platforms.

Inspection log

An inspection log is to be kept as a record of the lifting platform checks performed. The inspection log book must contain a report on the test performed prior to initial commissioning and the regular and exceptional checks, as well as the applicable certification on (EC) type testing and the EC declaration of conformity.

- The report must include:
- The date and scope of testing with details of any test items not yet performed
- The results of the test with details of any shortcomings established
- An assessment of whether there are any impediments to start-up or further use
- The details of any follow-up testing required
- The name, address and signature of the person carrying out the checks



The acknowledgement and rectification of any shortcomings found must be confirmed by the plant operator in the report.

3.The Scissor Lift

3.1 Overview of parts

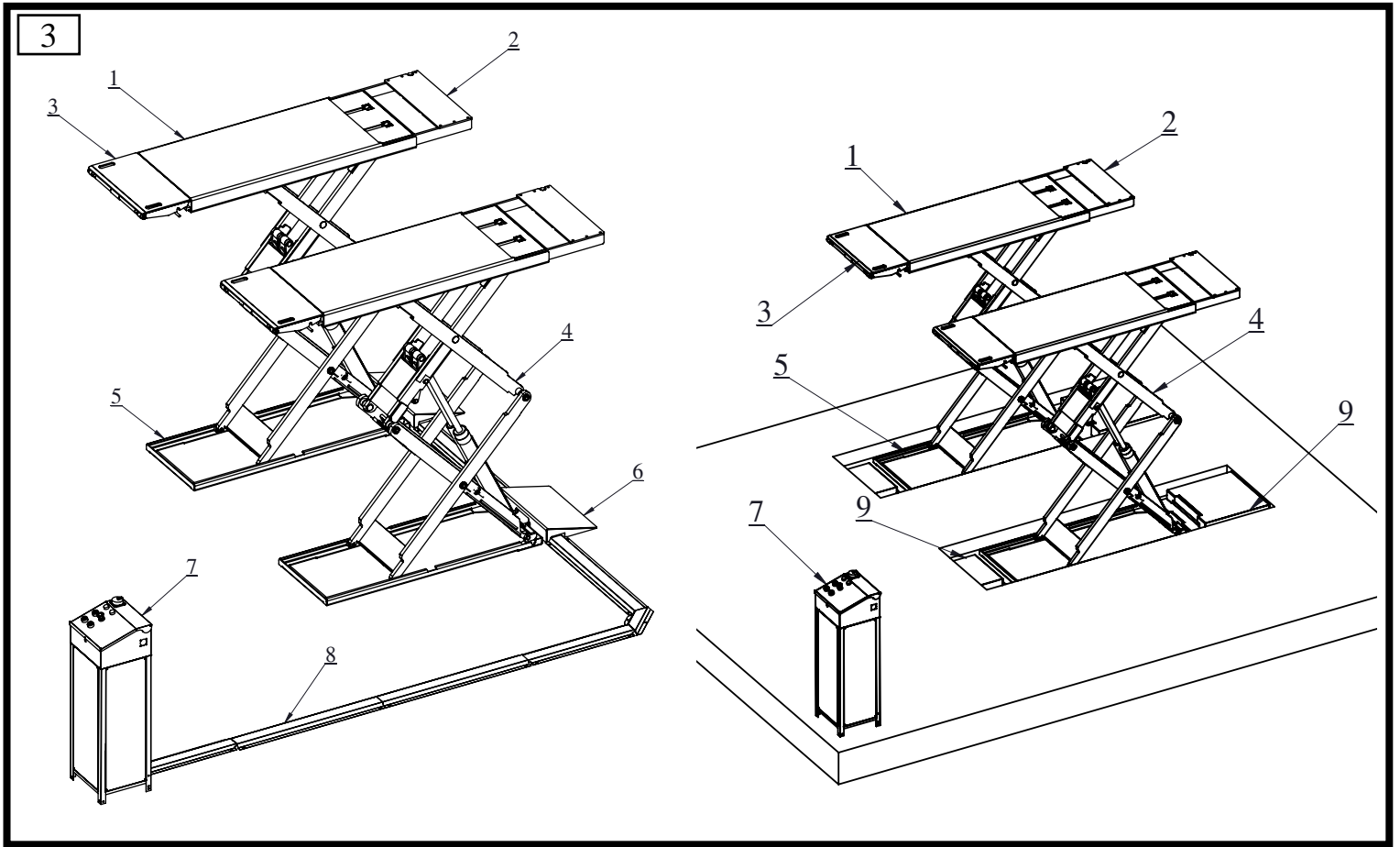

Figure 3: Scissors lift DS35EX

1. Lifting platform
2. Extension beam
3. Ramp
4. Scissors
5. Base frame
6. Ramp
7. Control cabinet
8. Hose Cover
9. Recess Box Kit (Only for Flush Mount Accessories)

3.2 General workflow

- After determining the vehicle data , the vehicle is driven over the platform.
- the manufacturer-approved pick-up points on the vehicle are selected and the matching supports are placed underneath. After checking that the weight distribution is correct, the vehicle is lifted by the scissor lift
- The vehicle is raised to the desired height with the scissor lift.
- After completion of the work, the vehicle is lowered again to the ground and driven off.



Risk of injury in the danger zone of the scissor lift in the event of incorrect behavior.



Only remain in the danger area if you have been trained and briefed and assigned to the area.



Keep the work area clean.



Keep escape routes clear so that you can leave the danger zone quickly and safely in the event of an emergency.

3.3 Work area, danger zones

Figure 4: Work area, Danger zones

1. Control area
2. Work area and danger zone
3. Vehicle overhang

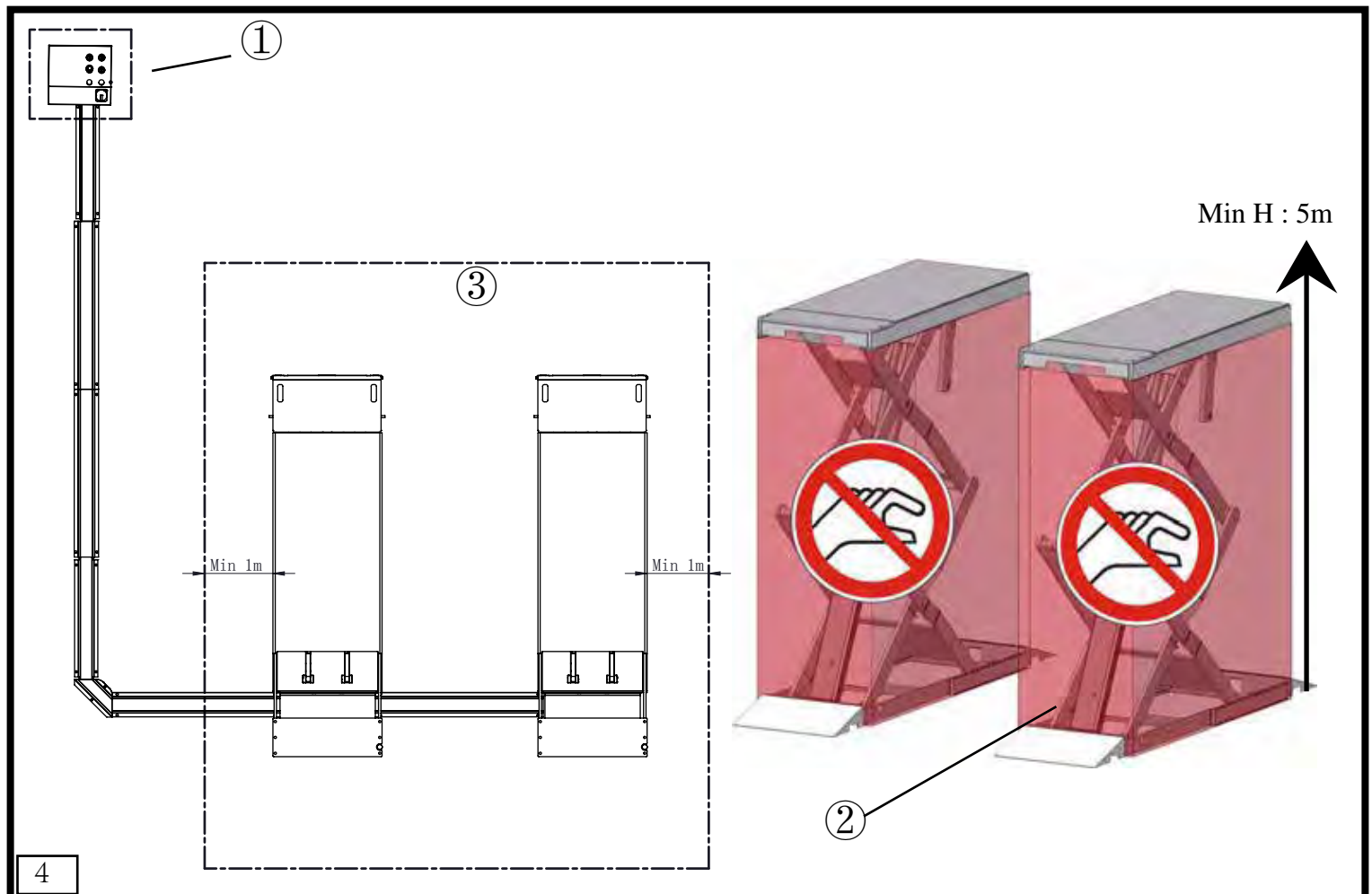

3.4 Safety mechanisms

See figures 5 ... 7



Safety mechanisms protect both people and lift. They must not be disabled!

- ➔ Scissor lift danger zones are protected by safety mechanisms.
- ➔ Function and condition of the safety mechanisms must be checked daily!
- ➔ If safety mechanisms are triggered, the scissor lift stops immediately.
- ➔ If safety mechanisms are defective, the scissor lift must be taken out of use immediately and the main switch locked with a padlock. Any further use must be prevented until the machine is fully repaired!
- ➔ If the scissor lift is moved or taken out of use for long periods, check the safety mechanisms before recommissioning and repair if necessary.

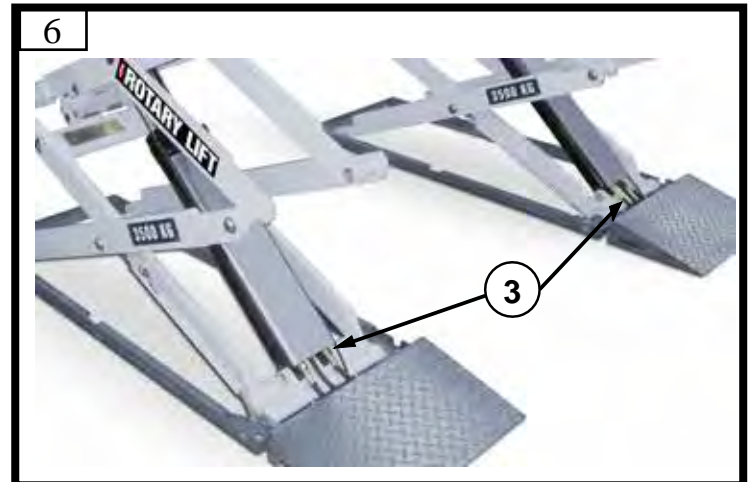
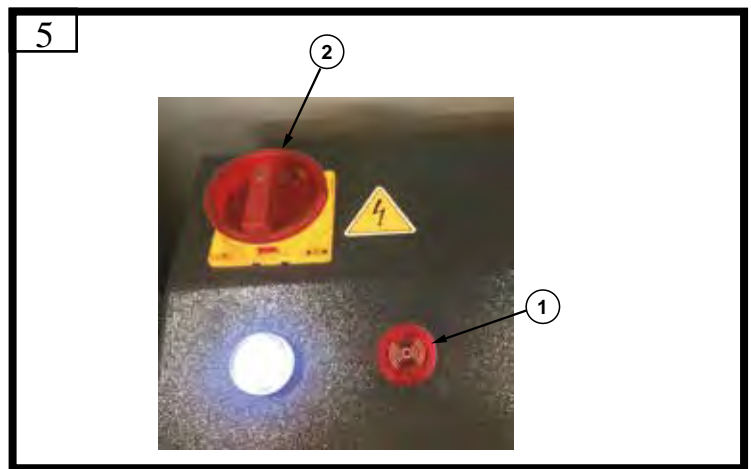

1. Buzzer

Acoustic alarm. Sounds:

- When lowering the scissor lift < 120 mm (foot protection).

2. Lockable main switch

"ON" setting: scissor lift ready for use.

"OFF" setting: scissor lift out of use. The mains voltage is still present inside the control box.

Switching off (OFF) immediately stops any movement of the scissor lift (= emergency stop, the scissor lift also set the emergency stop on the control).

3. Independent hydraulic circuits

Two hydraulic circuits independent of one another prevent the unintended lowering of the platform. In the event of a break in a hydraulic line in one of the hydraulic circuits, the other hydraulic circuit holds the platform.

4. Pressure limiting valve

The pressure limiting valve prevents overloading of the hydraulic system. It is factory preset and may not be adjusted by the operating company. When overloaded, the platform can no longer be raised.

5. Line breakage protection in the cylinder connection

The line-break safety device in the cylinder connection interrupts the flow if a break occurs in the hydraulic lines.

6. Deadman control

The deadman control of the machine ensures that the function is only carried out as long as the operator holds the respective control pressed on the control device.

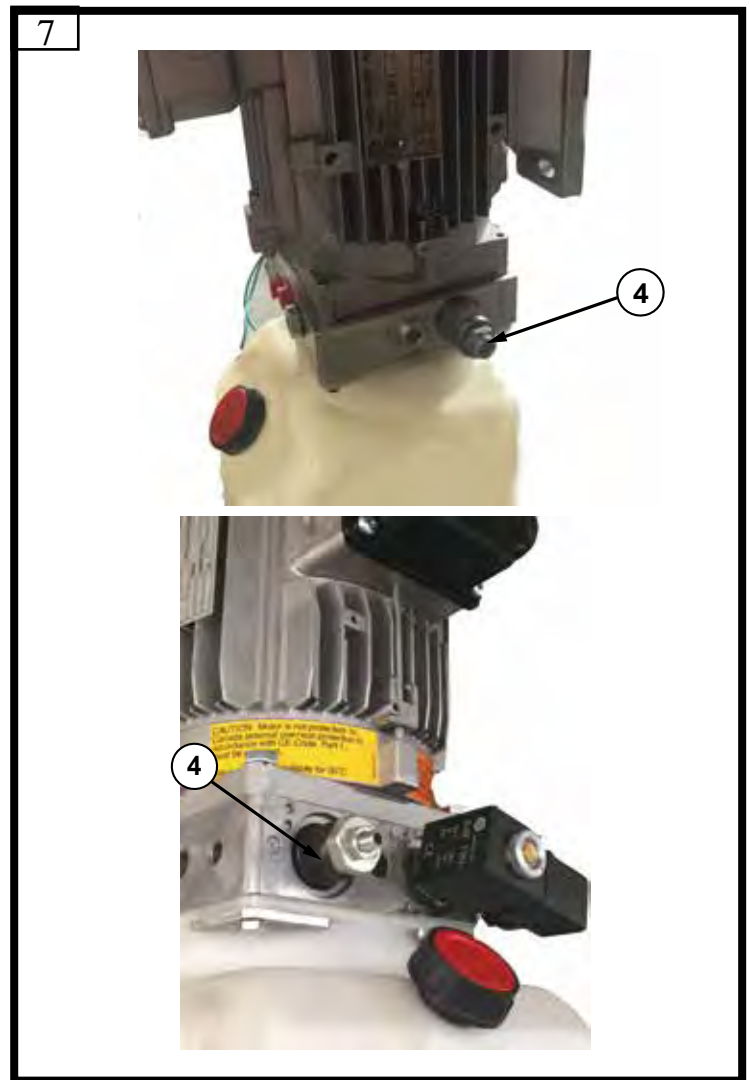

3.4 Control unit



All movement of the scissor lift stops immediately when you release a pressed button.

1. Lockable main switch

"ON" setting: Scissor lift ready for use.

"OFF" setting: Scissor lift out of use. The mains voltage is still present inside the control box.

Switching off (OFF) immediately stops any movement of the scissor lift (= emergency stop).

2. Power light

"Light" :Scissor lift with the power and ready for use.

"Dark" Scissor lift without the power and out of use.

3. Buzzer

Acoustic alarm. Sounds:

- When lowering the scissor lift < 120 mm (foot protection).

4. Emergency stop

Press the button, immediately stops any movement of the scissor lift .

5. LOWER TO GROUND button

Down button in the danger zone below 120mm

Only functions after the 120mm automatic shutoff has reacted to Down(6) . the platform can then be lowered completely if only button(5)is pressed at that time. A buzzer sounds throughout then entire lowering process.

6. Down button

Functions only if the button is pressed, the lift lower.

7. UP button

Functions only if the button is pressed, the lift raise.

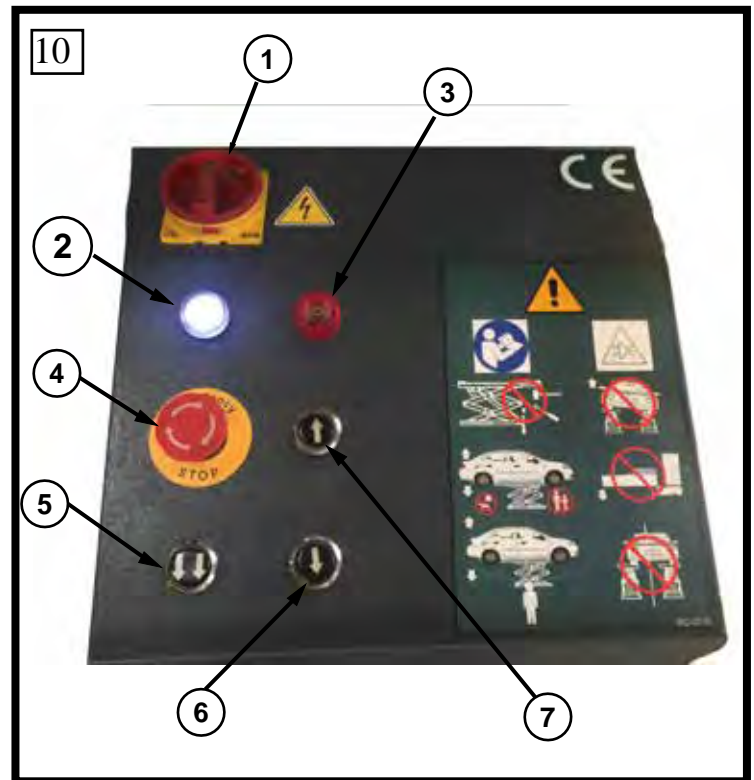

4. Operation



DANGER

To avoid personal injury and/or property damage, permit only trained personnel to operate lift. After reviewing these instructions, get familiar with lift controls by running the lift through a few cycles before loading vehicle on the scissor lift.



DANGER

Always lift the vehicle using all four rubber pads. NEVER raise just one end, one corner, or one side of vehicle. Assure vehicle frame can support its weight & overhead bar or sensor will contact highest point on the vehicle.



DANGER

Risk of injury when lowering the load onto objects below the lift or the vehicle. Vehicle may topple over.



Before lowering, you must remove all objects from underneath the lift. This applies in particular to chassis stands.



Always monitor the lift and vehicle carefully when lifting or lowering.



DANGER

Keep hand and feet clear of linkages while the scissor lift is being raised or lowered.



DANGER

Ensure overhead clearance is provided to raise vehicles to desired height.



DANGER

If the scissor lift is not operating properly, do not use until adjustments or repairs are made by a qualified lift service technician.



When working with the scissor lift, make sure you follow the instructions listed in Chapter 2. Safety.

4.1 Before Loading:

- Inspect Lift - See "Operator Inspection And Maintenance". Never operate if lift malfunctions or has broken or damaged parts.
- Lift must be fully lowered and service bay clear of all personnel before the vehicle is positioned onto lift.
- Assure area around lift is free of tools, debris, grease, and oil.
- Assure Adapter Pads are free from grease and oil.
- Do Not allow unauthorized persons in shop area while lift is in use.
- Do Not use any part of the lift as a crane or as a support for another lifting mechanism (i.e.: block & tackle, etc.).
- Turn main switch to "ON" Position, Fig 10. Also double check the emergency stop not pressed down.

4.2 Loading:

- Do Not allow unauthorized or untrained persons to position vehicle or operate lift.
- Do Not overload lift. See capacity label on lift.
- Check the condition of the pickup points of the vehicle.
- Vehicle unibody is strong enough to support its weight and has not been weakened by modification of corrosion.
- Use front ramp for vehicle support as necessary to reach front lift points.
- If pickup points can still not be reached, use extension beam for rear vehicle support.
- Use auxiliary rubber blocks to create clearance between vehicle chassis and lift pad,
- Auxiliary rubber pads are in secure contact with vehicle manufacturer's recommended lift points.

- Vehicle is stable on lift; neither front nor tail heavy.

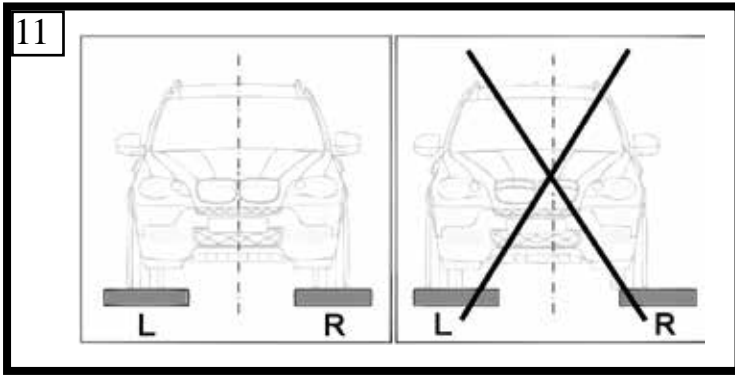

4.3 To Raise Lift:

- **Do Not** permit anyone on lift or inside vehicle when it is being raised or lowered.
- Actuate RAISE BUTTON.
- Raise vehicle until tires clear the floor.
- STOP: Check pads for secure contact with vehicle.
Shake car moderately at front or rear bumper.
- Continue to raise to desired height ONLY if vehicle is secure on lift. If necessary, lower lift and reposition using vehicle manufacture's recommended pick-up points.

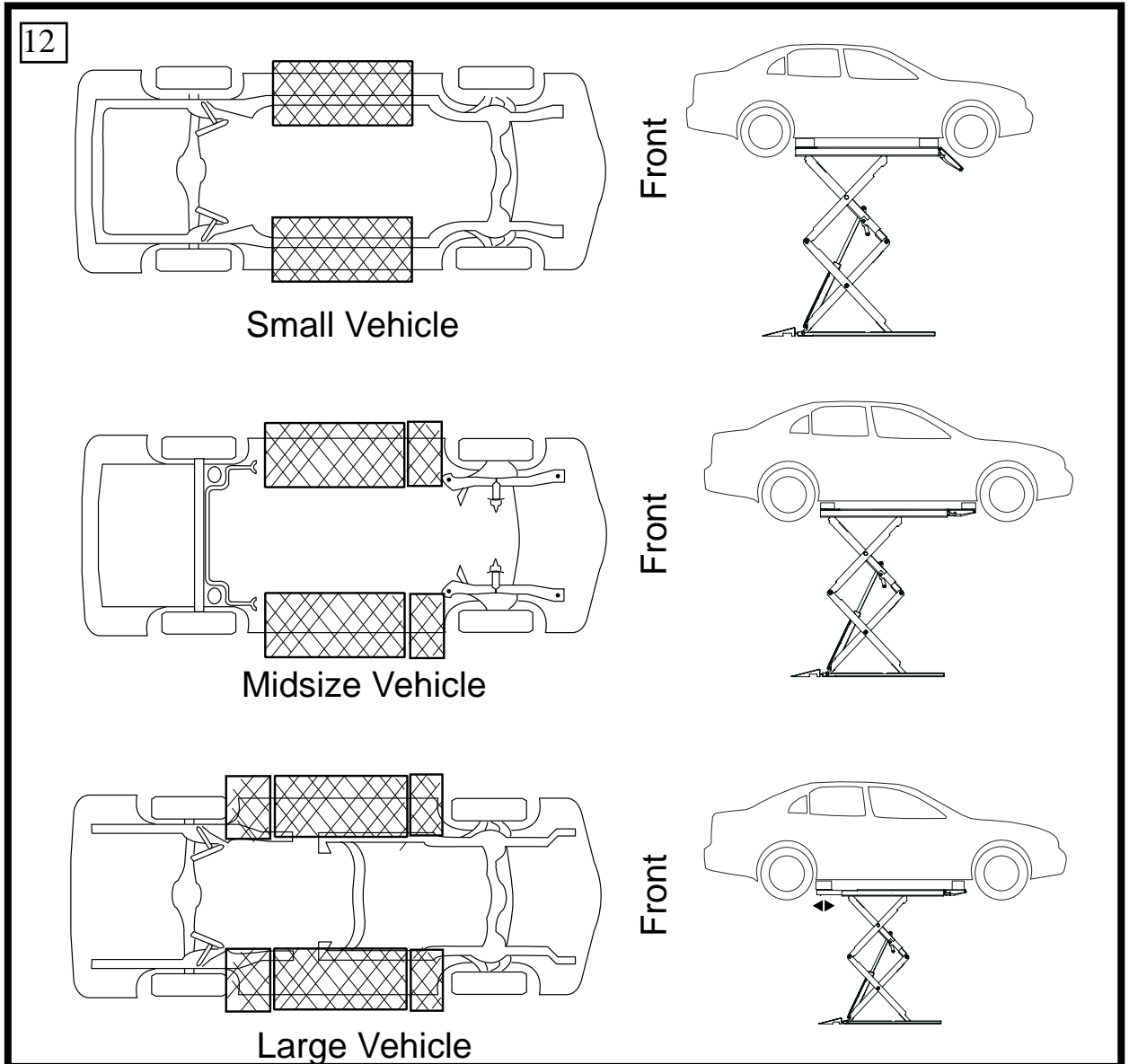



WARNING



Always make sure ramp is fully engaged when load on the ramp.

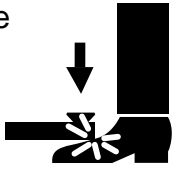

Always-keep feet clear of lift while lowering

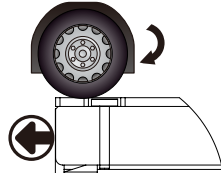

Always make sure the bolts stop extension out while vehicle drive onto the lift.

4.4 While Using Lift:

- Avoid excessive rocking of vehicle while on lift.
- Always use safety stands as needed for stability when removing or installing heavy components. (i.e.: engines, transmissions, etc.) Use 4 safety stands.
- Raise safety stands to meet vehicle, do not lower vehicle onto stands.
- Avoid accidental touching of exposed exhaust system on raised vehicles. Watch for air hoses and electrical cords which may be tripped over.
- Wear safety glasses while working under vehicle.

4.5 Before Lowering Lift:

- Remove all tools or other objects from lift area.
- Assure personnel are not in lift area.

4.6 To Lower Lift:

- Remain clear of lift when lowering vehicle. Keep Feet Clear!
- Actuate the LOWER BUTTON to lower lift until lift stops.
- Actuate LOWER TO GROUND button to lower remaining distance to ground.

4.7 Unloading:

- Assure lift is fully lowered.
- Remove any rubber blocks used when raising the vehicle.
- Carefully remove vehicle from lift area.

4.8 Power Off:

- Turn Main switch to "OFF" position while lift is not in use. if need, lock the switch with a padlock.

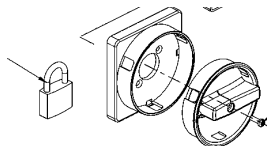

5. Problems, causes, actions

The following lists contain information on potential problems, their causes, and actions to rectify the fault.

i Repairs to safety equipment of the lift may only be operated by authorized maintenance technician (certified expert or competent person) be performed.

During a breakdown (power failure), the lift remains automatically in safe mode. This means that all movement is halted.

i If the lift is out of order for long periods, carry out the following steps:

1. Lower the lift to the lowest position.
2. Switch the main switch to Off and lock with a padlock.
3. Disconnect the power supply.

5.1 Troubleshooting by the operator

The following troubleshooting measures may only be carried out by an authorized operator.

Before doing so, make sure that power supply is connected, the main switch is in the "ON" position.

i If the problem is not rectified by the listed measures, you must seek advice from a competent person.

i The troubleshooting measures listed in 5.2 may only be carried out by maintenance contractors.

Problem	Possible cause	Actions
The motor is not running.	<ul style="list-style-type: none"> • Blown fuse or circuit breaker. • Overhead Sensor Actuated. • Up button not functioning. 	<ol style="list-style-type: none"> 1. Replace blown fuse or reset circuit breaker (customer side). 2. Check sensor or incorrect connection. 3. Check UP button. 4. Contact service representative for further assistance.
Motor runs but will not raise lift.	<ul style="list-style-type: none"> • Low oil level. • Overloading lift. 	<ol style="list-style-type: none"> 1. Check and Fill tank. 2. Check vehicle weight and/or balance vehicle weight on lift.
Lift won't lower.	<ol style="list-style-type: none"> 1. Down button not functioning. 2. Lowering Valve not functioning. 	Contact service representative for further assistance.
Lift going up unlevel.	See actions	Contact service representative for further assistance.
Anchors will not stay tight.	See actions	Contact service representative for further assistance.
Slow lifting speed or oil blowing out filler breather cap.	See actions	Contact service representative for further assistance.
Lift slowly settles down.	See actions	Contact service representative for further assistance.

5.2 Troubleshooting by authorized maintenance contractors

Problem	Possible cause	Actions
Motor does not run.	<ol style="list-style-type: none"> 1. Blown fuse/circuit breaker. 2. Incorrect voltage to motor. 3. Bad wiring connections. 4. Up switch burned out. 5. Motor windings burned out. 	<ol style="list-style-type: none"> 1. Replace fuse or reset breaker. 2. Supply correct voltage to motor. 3. Repair and insulate all connections. 4. Replace switch/control buttons. 5. Replace motor.
Motor runs but will not raise lift.	<ol style="list-style-type: none"> 1. Overloading lift. 2. Motor running on low voltage. 3. Debris in lowering valve. 4. Pump sucking air. 5. Suction stub off pump. 	<ol style="list-style-type: none"> 1. Check vehicle weight and/or balance vehicle weight on lift. 2. Supply correct voltage to motor. 3. Clean lowering valve. 4. Tighten all suction line fittings. 5. Replace suction stub.

	<ol style="list-style-type: none"> 6. Low oil level. 7. Improper relief valve adjustment. 8. Open lowering valve. 	<ol style="list-style-type: none"> 6. Fill tank to proper level . 7. Replace relief valve. 8. Repair/replace lowering valve.
Lift slowly settles down.	<ol style="list-style-type: none"> 1. Debris in check valve seat. 2. Debris in lowering valve seat. 3. External oil leaks. 	<ol style="list-style-type: none"> 1. Clean check valve. 2. Clean lowering valve. 3. Repair external leaks.
Oil blowing out filler breather cap.	<ol style="list-style-type: none"> 1. Oil Leak/Pump Failure. 2. Incoming Motor Voltage Incorrect. 3. Vehicle Weight And Balance Not Within Lift Capacity. 	<ol style="list-style-type: none"> 1. External oil leak-locate and repair leak. Internal oil leak-have hydraulic system serviced by an authorized service representative. 2. Supply correct voltage to motor, contact your local service authority. 3. Use lift only to rated capacity.
Lift Fails To Raise When Pushing Raise Button.	<ol style="list-style-type: none"> 1. Raise button defective. 2. Vehicle weight and balance not within lift capacity 3. Motor rotation incorrect. 4. Incoming motor voltage incorrect or insufficient 5. Loose or damaged wiring 6. Blown fuse. 	<ol style="list-style-type: none"> 1. Replace raise button. 2. Use lift only at rated load. 3. Switch the phase and make sure motor turns in the direction indicated by the arrow. 4. Supply correct voltage to motor, contact your local service authority. 5. Inspect and repair loose or damaged wiring. 6. Check for blown fuse.
The lowering button is pressed but the lift does not lower.	<ol style="list-style-type: none"> 1. Obstacles blocking the lowering phase. 2. Switch is off or power supply is interrupted. 	<ol style="list-style-type: none"> 1. Remove the obstacles blocking the lowering phase. 2. Check and supply power to lift.
The lift is lowered but one of the two platforms is higher.	<ol style="list-style-type: none"> 1. Make sure there are no obstacles under the higher platform. 2. Platforms are not level. 3. Air is in one of the slave cylinders. 	<ol style="list-style-type: none"> 1. Remove the obstacle and carefully check the area before operating the lift. 2. Check to see if lift is installed on unlevel floor. Level per installation instructions if needed. 3. Should this problem occur, check the lift for oil leaks from the cylinders or pipes, if necessary purge slave cylinder by pressing the "Override Up" button on the printed circuit board located in the cabinet and hold for approximately 40 seconds.

<p>Anchors will not stay tight.</p>	<ol style="list-style-type: none"> 1. Holes drilled oversize. 2. Concrete floor thickness or holding strength not sufficient. 	<ol style="list-style-type: none"> 1. Relocate lift using new bit to drill holes. Reference installation instructions for proper anchoring method and minimum spacing requirements. 2. Break out old concrete and re-pour new pads for lift per lift installation instruction.
<p>Lift stops short of full rise or chatters.</p>	<ol style="list-style-type: none"> 1. Air in hydraulic lines or cylinder. 2. Low oil level. 	<ol style="list-style-type: none"> 1. Start unit, raise lift about 610mm. Open cylinder bleeders approximately 2 turns. Close bleeders when fluid streams. Fully lower lift and refill power unit per Step 2 below. 2. Fully lower lift. Fill tank .

6 Authorized lowering

If the car lift cannot perform lowering operations because of power supply interruption, faulty hydraulic valves, or electric trouble in the system, the lift can be lowered manually. For manual lowering operation (emergency), perform the following:



Manual lowering (emergency) operations should be performed by authorized personnel specially trained for operating the car lift only.

- Make sure there are no obstacles blocking the lowering phase; **remember that the car lift may not be lifted again to remove possible obstacles.**
- Disconnect main power supply.
- P3664 and P3669 - Pull left valve and push right valve at the same time, pig 13a
- P3660 push the spool of valve on the main power unit and also the additional valve at same time.

For Power Unit part number details see Parts Breakdown.

13



P3664&P3669



P3660

7. Technical data

Verlängerung ausziehbar
extensions extendable

Kabelkanal
cable channel

Bedienpult
operating unit

max. 1940

2358

1830

1500

528

min. 160

OKFFB
ohne Estrich/Fliesen
without floor pavement/tiles

Die Position des Bedienpults kann den örtlichen Gegebenheiten angepasst werden. Ggf. sind die Versorgungsleitungen, Kabelkanäle anzupassen.
The position of the operating unit can be adapted. If necessary extend the power supply lines and the cable channel.

OKFFB ohne Estrich/Fliesen
without floor pavement/tiles

min. 160

Betonqualität
quality of concrete
min. C20/25
normal bewehrt
normal armoured

empfohlene Dübel / recommended anchors

Hilti: HST3 M12x145 70/50

MKT: VMZ-A100M12-25/145

Die Mindestverankerungstiefe des Dübels beachten. Mit Estrich/Fliesen sind längere Dübel einzusetzen. Observe the min. anchorage of the dowels. With floor pavements, (e.g. tiles) use longer dowels.

Es können auch gleichwertige Dübel verwendet werden. You can use also equivalent dowels.

Die Montagevorschrift des Dübelherstellers immer beachten. Observe always the regulation of the dowel manufacturer

* BMW Version 900mm

630

800 (*)

630

Bedienpult wahlweise rechts oder links möglich
operating unit alternatively right or left side possible

Einfahrtrichtung empfohlen

Hydraulikkittungen (A+B) 6000 mm

360x340x1100

Kabelkanal
cable channel

Netzanschluss:
3PH, 400V, 50Hz/60HZ Cable □ 3L+PE/ 4*1.5'/ Länge 3m/ 16A
3PH, 230V, 50Hz/60HZ Cable □ 3L+PE/ 4*1.5'/ Länge 3m/ 25A
1PH, 230V, 50Hz/60HZ Cable □ L+N+PE/ 3*2.5'/ Länge 3m/ 32A
Motorleistung: 3 kW

Prepared by customer at the main operating unit:
power supply:
3PH, 400V, 50Hz/60HZ Cable □ 3L+PE/ 4*1.5'/ length 3m/ 16A
3PH, 230V, 50Hz/60HZ Cable □ 3L+PE/ 4*1.5'/ length 3m/ 25A
1PH, 230V, 50Hz/60HZ Cable □ L+N+PE/ 3*2.5'/ length 3m/ 32A
Motor power 3 kW

Alle Maße in Millimeter
all dimensions in millimeter
Maß- und Konstruktionsänderungen vorbehalten!
subject to alterations!

max. Belastung auf den Grundrahmen der Hebebühne
max. load acting on the base frame
Eigengewicht / own weight 700kg

Lastverteilung 1
load condition 1

Lastverteilung 2
load condition 2

Festlager
fixed point

Gleitstücke
sliding blocks

Tragfähigkeit: max. 3500kg
capacity

DS35EX

UNLESS OTHERWISE NOTED:
DO NOT SCALE DRAWING
UNLESS OTHERWISE SPECIFIED
DIMENSIONS ARE IN MILLIMETERS
REMOVE ALL BARS

NOTES:

THIS DESIGN AND DETAIL ILLUSTRATED IN THIS DRAWING IS THE PROPERTY OF VEHICLE SERVICE GROUP. IT IS BEING LOANED WITH THE EXPRESSED CONDITION THAT IT WILL NOT BE REPRODUCED OR TRANSMITTED IN ANY FORM OR BY ANY MEANS, ELECTRONIC OR MECHANICAL, INCLUDING PHOTOCOPYING, RECORDING, OR BY ANY INFORMATION STORAGE AND RETRIEVAL SYSTEM, WITHOUT PERMISSION AND IS SUBJECT TO RETURN UPON REQUEST.

REV/ CO NUM DATE BY

SCALE

DATE

APPROVED

DRAWING NUMBER

DS35EX-HG_8537

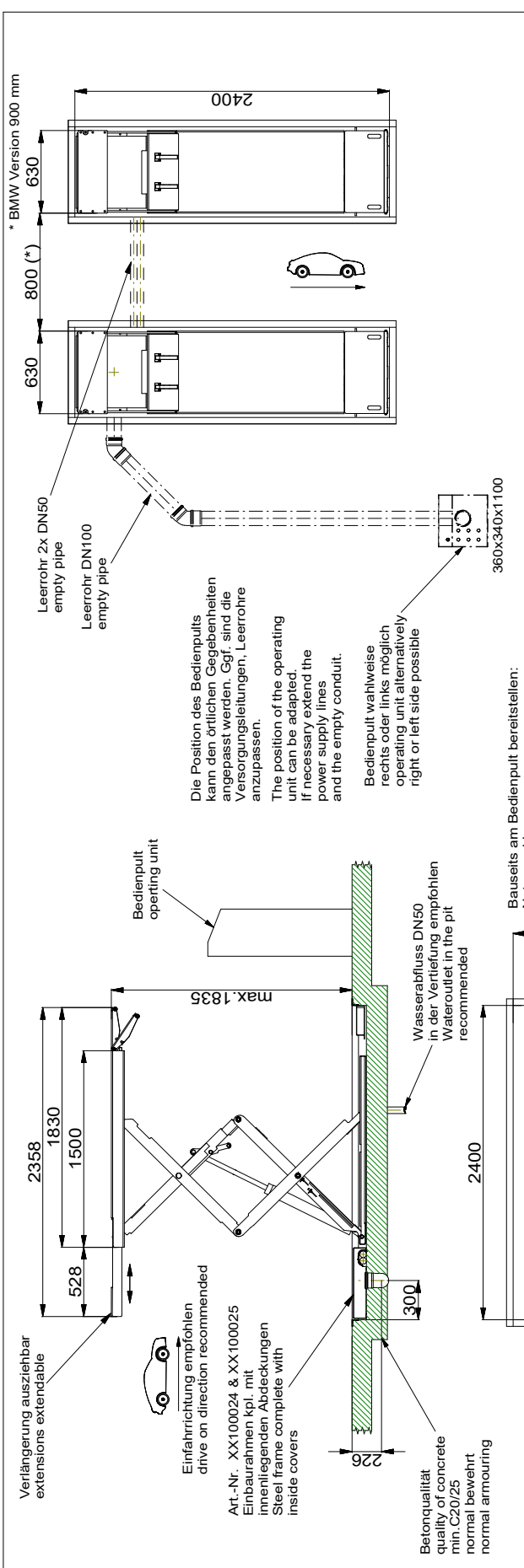

Die Position des Bedienpults kann den örtlichen Gegebenheiten angepasst werden. Ggf. sind die Versorgungsleitungen, Leerrohre anzupassen.
The position of the operating unit can be adapted. If necessary extend the power supply lines and the empty conduit.

Bedienpult wahlweise rechts oder links möglich
operating unit alternatively right or left side possible

Bauseits am Bedienpult bereitstellen:
Netzanschluss:
3PH, 400V, 50Hz/60HZ Cable □ 3L+PE/4*1.5'/ Länge 3m/ 16A
3PH, 230V, 50Hz/60HZ Cable □ 3L+PE/4*1.5'/ Länge 3m/ 25A
1PH, 230V, 50Hz /60HZ Cable □ L+N+PE/ 3*2.5'/ Länge 3m/ 32A
Motorleistung: 3 kW

Prepared by customer at the main operating unit:
power supply:
3PH, 400V, 50Hz/60HZ Cable □ 3L+PE/4*1.5'/ length 3m/ 16A
3PH, 230V, 50Hz/60HZ Cable □ 3L+PE/4*1.5'/ length 3m/ 25A
1PH, 230V, 50Hz /60HZ Cable □ L+N+PE/ 3*2.5'/ length 3m/ 32A
Motor power: 3 kW

Detail "X"

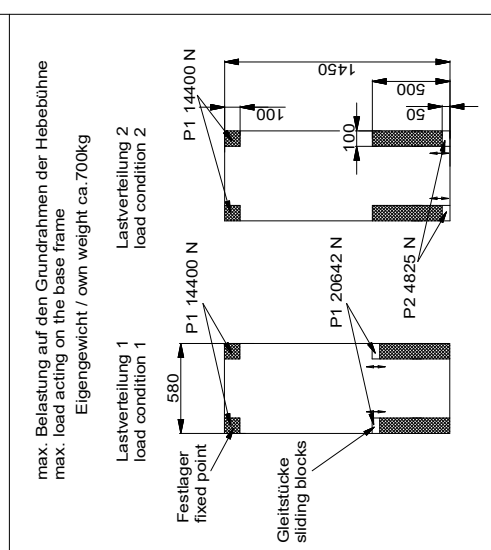
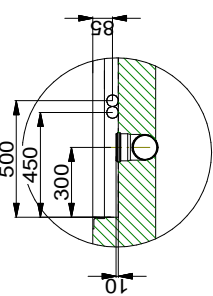

THIRD ANGLE PROJECTION	DS35EX
DO NOT SCALE DRAWING (UNLESS OTHERWISE NOTED) OTHER DIMENSIONS: ± 1 mm OTHER DIMENSIONS: ± 0.8mm (≤ 305mm) ± 1.6mm (≥ 305mm)	Unterflur / Ingrund
UNLESS OTHERWISE NOTED: ANGULAR DIMENSIONS: ± 1° OTHER DIMENSIONS: ± 0.8mm (≤ 305mm) ± 1.6mm (≥ 305mm)	Tragfähigkeit: max. 3500kg capacity
NOTES: The design and detail illustrated in this drawing is the property of Vehicle Service Group. It is being loaned with the expressed condition that it will not be duplicated or used except by permission and is subject to return upon request.	
REV	CO NUM
DATE	BY
MG	SCALE
APPROVED	DATE
18.07.2017	DS35EX-HG_8538
SHEET	DRAWING NUMBER

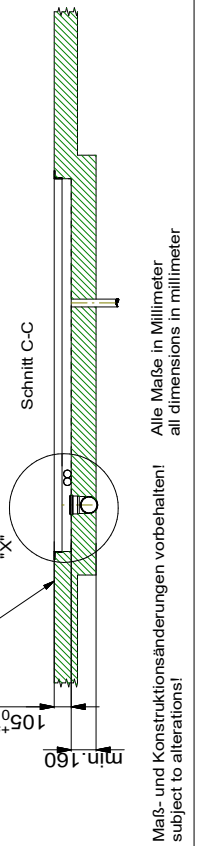

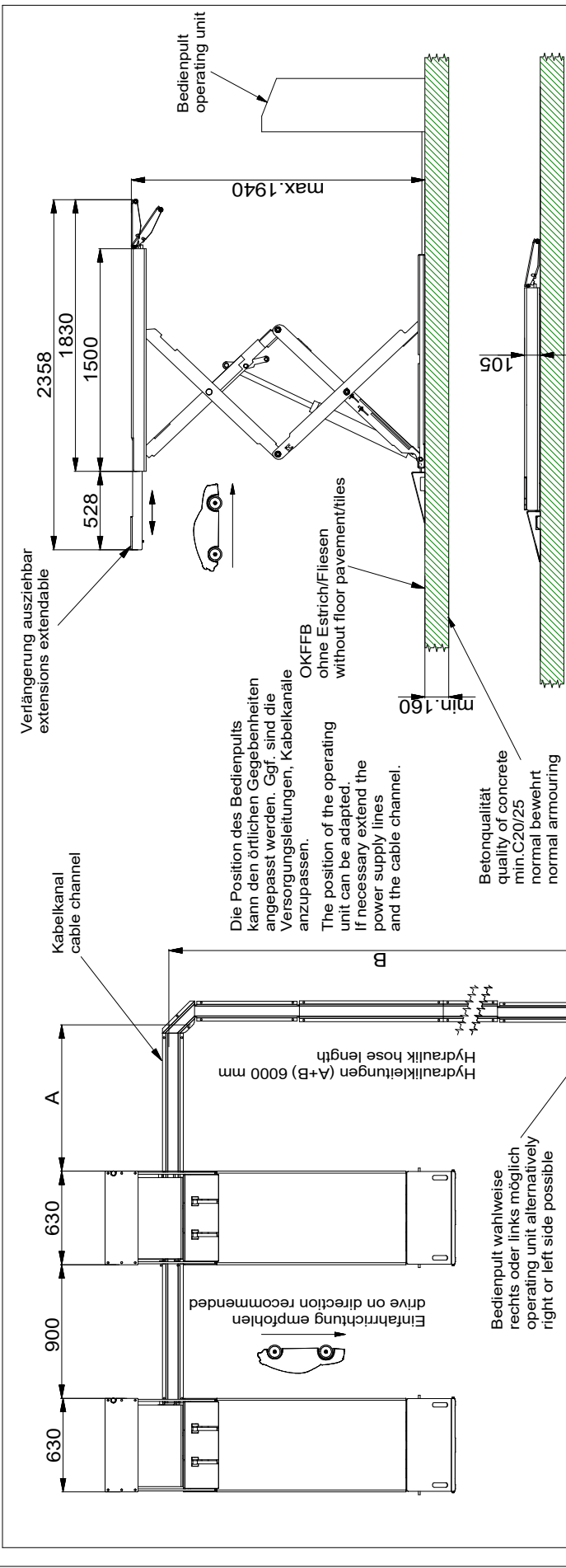

empfohlene Dübel / recommended anchors

Hilti:
HST3 M12x145 70/50

MKT:
VMZ-A100M12-25/145

Die Mindestverankerungstiefe des Dübels beachten.
Mit Estrich/Fliesen sind längere Dübel einzusetzen.
Observe the min. anchorage of the dowels. With floor pavements, (e.g. tiles) use longer dowels.

Es können auch gleichwertige Dübel verwendet werden.
You can use also equivalent dowels.

Die Montagevorschrift des Dübelherstellers immer beachten.
Observe always the regulation of the dowel manufacturer

Tragfähigkeit: max. 3500kg
capacity

Alle Maße in Millimeter
all dimensions in millimeter

Maß- und Konstruktionsänderungen
subject to alterations!

UNLESS OTHERWISE NOTED:
ANGULAR DIMENSIONS: +0, -1 (0,5mm)
OTHER DIMENSIONS: +0, -1 (0,5mm)
0 DIMINAL, CORNER/BREAK
DIMENSIONS: ALL DIMENSIONS

NOTES:
Tragfähigkeit: max. 3500kg
capacity

The design and detail illustrated in this drawing is the property of Vehicle Technology and shall not be duplicated or used except by permission and is subject to return upon request.

DS35EX
BMW Version

DRAWN: MG
SCALE: 1:1
SHEET: 1
DATE: 18.07.2017
APPROVAL: DS35EX-HG_BMW_8539

Verlängerung ausziehbar
extensions extendable

Kabelkanal
cable channel

Die Position des Bedienpults kann den örtlichen Gegebenheiten angepasst werden. Ggf. sind die Versorgungsleitungen, Kabelkanäle anzupassen.
The position of the operating unit can be adapted. If necessary extend the power supply lines and the cable channel.

OKFFB ohne Estrich/Fliesen
without floor pavement/tiles

min. 160

Betonqualität
quality of concrete
min. C20/25
normal bewehrt
normal armoured

Bauseits am Bedienpult bereitstellen:
Netzanschluss:
3PH, 400V, 50Hz/60HZ Cable □ 3L+PE/4*1.5'/ Länge 3m/ 16A
3PH, 230V, 50Hz/60HZ Cable □ 3L+PE/4*1.5'/ Länge 3m/ 25A
1PH, 230V, 50Hz /60HZ Cable □ L+N+PE/ 3*2.5'/ Länge 3m/ 32A
Motorleistung: 3 kW

Prepared by customer at the main operating unit:
power supply:
3PH, 400V, 50Hz/60HZ Cable □ 3L+PE/4*1.5'/ length 3m/ 16A
3PH, 230V, 50Hz/60HZ Cable □ 3L+PE/4*1.5'/ length 3m/ 25A
1PH, 230V, 50Hz /60HZ Cable □ L+N+PE/ 3*2.5'/ length 3m/ 32A
Motor power 3 kW

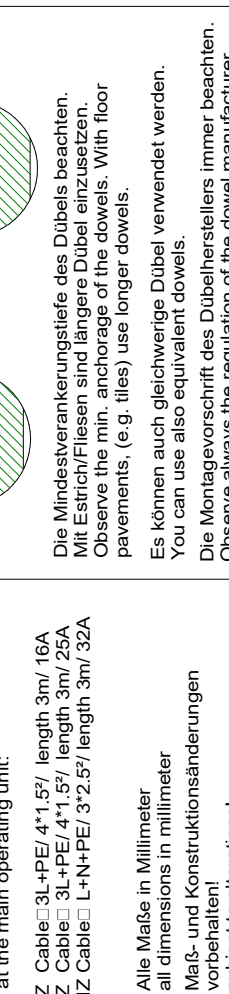

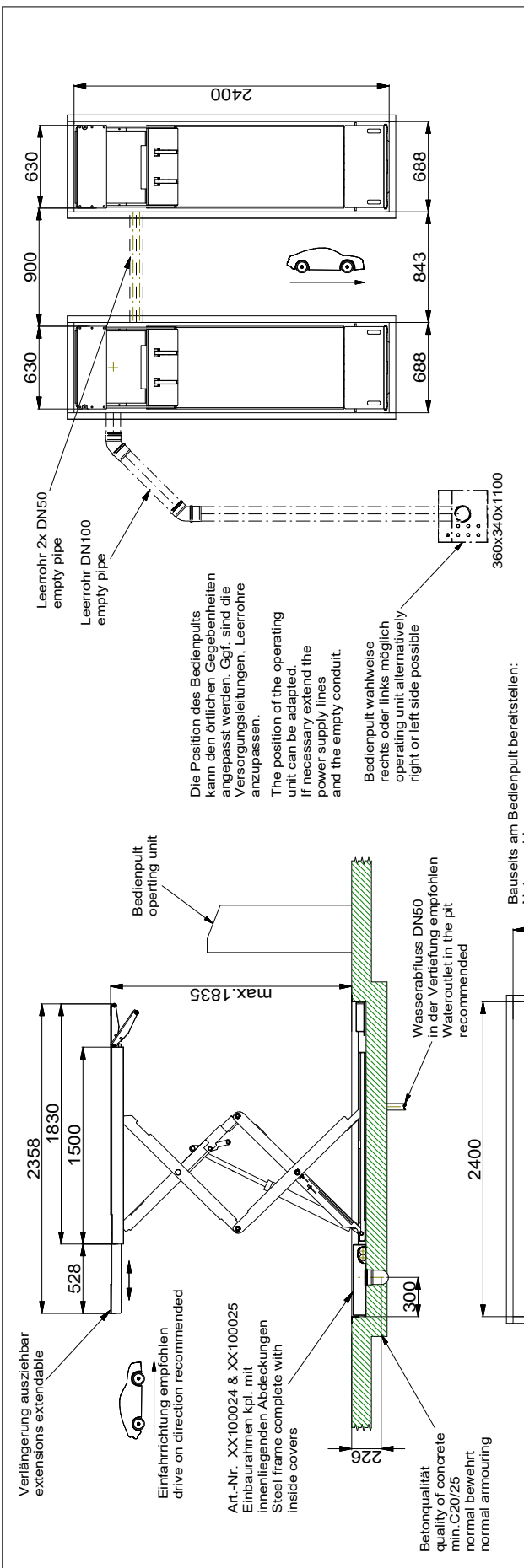

Die Position des Bedienpults kann den örtlichen Gegebenheiten angepasst werden. Ggf. sind die Versorgungsleitungen, Leerrohre anzupassen.
The position of the operating unit can be adapted. If necessary extend the power supply lines and the empty conduit.

Bedienpult wahlweise rechts oder links möglich operating unit alternatively right or left side possible

Bauseits am Bedienpult bereitstellen:
Netzanschluss:
3PH, 400V, 50Hz/60HZ Cable □ 3L+PE/ 4*1.57/ Länge 3m/ 16A
3PH, 230V, 50Hz/60HZ Cable □ 3L+PE/ 4*1.57/ Länge 3m/ 25A
1PH, 230V, 50Hz/60HZ Cable □ L+N+PE/ 3*2.57/ Länge 3m/ 32A
Motorleistung: 3 kW

Prepared by customer at the main operating unit:
power supply:
3PH, 400V, 50Hz/60HZ Cable □ 3L+PE/ 4*1.57/ length 3m/ 16A
3PH, 230V, 50Hz/60HZ Cable □ 3L+PE/ 4*1.57/ length 3m/ 25A
1PH, 230V, 50Hz/60HZ Cable □ L+N+PE/ 3*2.57/ length 3m/ 32A
Motor power 3 kW

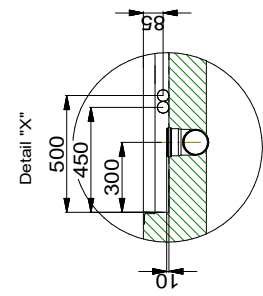
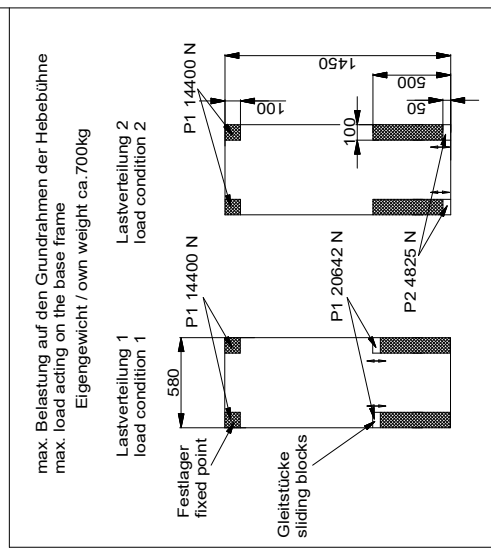

THIRD ANGLE PICTORIAL		DS35EX	
DO NOT SCALE DRAWING		Unterflur / Inground BMW Version	
UNLESS OTHERWISE SPECIFIED: ANGULAR DIMENSIONS: ±0.1° OTHER DIMENSIONS: ±0.8mm (<05mm) ±1.18mm (bores 305mm)		VSB	
NOTES: Tragfähigkeit: max. 3500kg capacity		DRAWING NUMBER DS35EX-HG_BMW_8540	
REV	CO NUM	DATE	BY

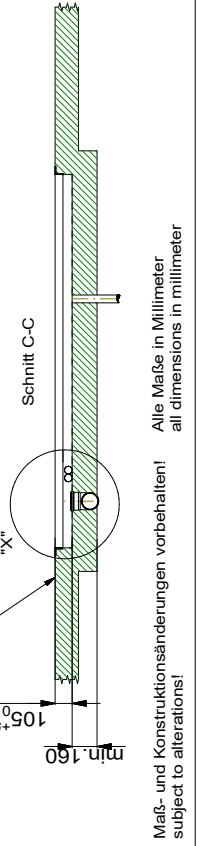

Maß- und Konstruktionsänderungen vorbehalten!
subject to alterations!

Alle Maße in Millimeter
all dimensions in millimeter

8.Cleaning

- Only clean the lift when not loaded (without vehicle).
- Clean main lift, and all work areas daily. In doing so, always keep all lift components clean.



If the lift is in a particularly dirty environment, clean accordingly more frequently.

- Do not use abrasive cleaning materials on lift parts and covers. Use lint-free cloth.
- Do not use compressors or high pressure cleaners for cleaning work.
- Always consult a maintenance contractor if you identify a hazard.
- Prior to maintenance make sure that fittings and fixtures are free of oil, lubricants, and cleaning materials.

9.Maintenance and repair



DANGER

Inadequate maintenance and repair work may cause serious injury and also lead to damage to property. A safety risk as well as a risk of fatal injury exists during operation.

- ➔ Follow the maintenance and repair instructions below carefully.
- ➔ Regularly clean the scissor lift (Chapter 8).
- ➔ Comply with maintenance intervals (→ Chapter 9.3). This will keep the lift in perfect working condition and guarantee safe operation.
- ➔ Maintenance and repair work must be documented (→ annex, maintenance schedule, regular maintenance reports, and repair reports).

9.1 Qualification of maintenance and repair staff

Maintenance and repair work may only be carried out by an authorized **maintenance contractor** (→ Chapter 2.6).

9.2 Maintenance and repair safety regulations

- Only qualified electricians may work on electrical equipment on the machine.
- Only qualified staff with specialist knowledge and experience with hydraulics or pneumatics may work on hydraulic or pneumatic equipment.
- **Ensure that you follow the instructions listed in 2, Safety.**
- When working on the hydraulics or on pneumatic equipment, ensure that you follow the safety regulations listed in the supplied power unit operating instructions annexed to this manual.
- Only perform maintenance on unloaded lifts .

- Prevent environmental hazards:
 - Mineral-oil-based hydraulic oil is combustible and a water pollutant. It must only be used in conjunction with the relevant safety data sheet and if all specified measures contained therein are implemented.
 - Provide suitable oil drain pans and oil absorbers.
 - Ensure that no hydraulic oils, lubricants or cleaning materials contaminate the soil or leak into the drainage system.
 - Comply with local regulations for handling water pollutants, for example for absorbing leaking fluids or fluids from oil separators.
- Avoid contact with or inhalation of toxic substances such as hydraulic fluid.
- Wear protective clothing, for example protective goggles, protective gloves etc.
- Before all maintenance and repair work:
 - secure the scissor lift zone with a red-white chain and warning notices.
 - turn the main switch to OFF ("OFF" Position).
 - inform all persons in the area about the maintenance and repair work.
- Only use original spare parts from the manufacturer.
- Tighten all fittings after maintenance work according to the specified torque figures.
- The default setting for safety valves must be a maximum of 10 % or a minimum of 20 bar above the operating pressure of the machine. The safety valve settings may not be adjusted.
- Remove all used materials, tools and other objects from the danger zone after cleaning, maintenance, and repair work.
- Dispose of hydraulic oils, lubricants, cleaning materials, and replaced parts in accordance with environmental regulations.

9.3 Maintenance work



WARNING

Potential crushing and shearing hazard to limbs caused by uncontrolled lowering motion.



In particularly dirty environments, maintain the scissor lift accordingly more frequently
Only perform maintenance on unloaded lifts, i.e. without vehicle.



WARNING

Risk to people and the environment caused by toxic substances when emptying or filling the hydraulic oil tank.



Avoid contact with or inhalation of hydraulic oil or Vaseline oil.
Provide a suitable oil drain pan and oil absorbent.
Ensure that used oil doesn't contaminate the soil or wash away into the drainage system.
Comply with local regulations for handling water pollutants.
Dispose of used oil in an environmentally friendly manner.
Hydraulic oil is highly inflammable, combustible.



DANGER

Risk of fatal injury if anchor bolts are loose. Post lift may slip, the load may collapse.



Stop operating the scissor lift.
Secure the scissor lift. If this cannot be done, provide an approved foundation then anchor and secure the scissor lift properly.

- Always keep all bolts and nuts tight. Check periodically.
- Always raise lift when cleaning floor area.
- Always keep lift clean. Keep bottom weldment dry and free from corrosives such as salt and cleaning fluids.
- Daily: Inspect rubber blocks for damage or excessive wear. Replace as required with genuine Rotary parts.
- Daily: With a representative vehicle on the lift, check the lowering speed (not to exceed 0.15m/s)
- Weekly: Inspect all lift parts for signs of damage due to overloading and rough handling.
- Monthly: Carry out a function test with and without load.
- Monthly: Lightly grease sliding surfaces(fig 14 Item 2) and top cylinder clevis pin with all purpose grease.
- Monthly: Check level of platforms, rebleed air from cylinders if needed(pressing the "Override Up" button on the printed circuit board located in the cabinet and hold for approximately 40 seconds).
- Monthly: Inspecting the sliding blocks(fig14 item2) and sliding bearing (fig 14 item 1) ,perform a visual check for wear.
- Semi-Annually: Check fluid level of lift power unit while lift is fully lowered. Refill if required per fill line on tank. If fluid is required, inspect all hoses and and cylinder for leakage (Visual inspection) .with lift loaded,stop the lift at midpoint of travel and observe for drifting down and hydraulic leaks. Repair or replace as required.
- Semi-Annually: Check anchor bolts to ensure the torque according to the supplier of the anchor bolts.
- Annual: Inspect electrical cables for damage(visual inspection).
- Annual:Check that control buttons and switches function properly.
- If lift stops short of full rise or chatters, check fluid level and purge both cylinders per lift installation instructions.
- Replace all CAUTION, WARNING, or SAFETY related decals on the lift if unable to read or missing. Reorder labels from Rotary Lift.
- Complete maintenance report and inspection report from safety inspection (→ Annex).

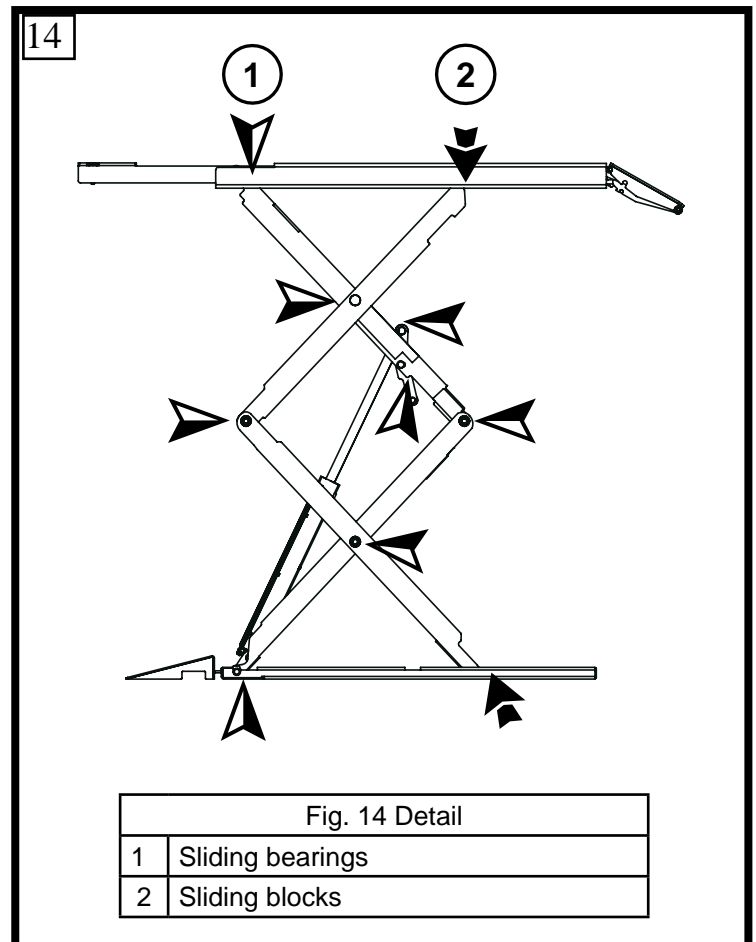

9.4 Approved hydraulic oils



Important information

- Only use hydraulic oils in accordance with DIN 51524 for the hydraulic system.
- Only use biodegradable oils (HEES-based on synthetic esters).
- Use PTFE seals or foam elastomers if the water content is high.

ATTENTION Seals may be destroyed if the incorrect hydraulic oil is used.

- ➔ Do not use rapeseed based oils. The water content of the hydraulic oil must not exceed 2%.
- ➔ Do not mix bio-oils with mineral oils. Mixing leads to foaming problems and corrosion damage.
- ➔ Make sure that the oil is not contaminated by any other oil or water.
- ➔ Use a proportionally lower viscosity bio-oil as a replacement for mineral oil. This improves the lubrication properties, reduces energy consumption and generates less heat.

HEES32-bio-oils can, for example, be used as a replacement for mineral oil HLP46:

- PLANTOSYN 3268
- BECHEM HYDROSTAR HEES 32
- BP Biohyd 32
- Mobil EAL Hydraulic Oil 32



Oils and grease

Only use consistency classification II oils and grease.



Water pollutants

Oils and grease are water pollutants in terms of the Water Management Act (WGH).



Always dispose of these in an environmentally friendly manner in compliance with the applicable regulations in your country (→ Chapter 14. Disposal).

9.5 Check, refill, change the hydraulic oil



WARNING

Risk to people and the environment from toxic substances when filling the hydraulic oil tank.

- ➔ Avoid contact with and inhalation of hydraulic oil.
- ➔ Wear protective clothing (protective goggles, protective gloves). Provide suitable oil drain pans and oil absorbers.
- ➔ Ensure that no hydraulic oils, lubricants, or cleaning materials contaminate the soil or leak into the drainage system.
- ➔ Comply with local regulations for handling water pollutants, for example for absorbing leaking fluids or fluids from oil separators.
- ➔ Hydraulic oil is highly inflammable, combustible.

1. Open the cabinet and Check hydraulic oil level on the hydraulic oil tank.



The oil level must not exceed the minimum value ("min").

2. Place the oil drain pan under the tank, remove tank cap and refill hydraulic oil to the "max" mark.
3. Ensure that the vents work and that no vacuum is generated.
4. Screw on the tank cap so that the tank is properly sealed.
5. Remove oil residues on the floor or on the lift with an approved detergent. Dispose of used cleaning cloths in the correct manner.
6. Complete a maintenance report (→ Annex).

An oil change is carried out depending on the extent to which the hydraulic oil has degraded. To do so, proceed as follows:

1. Lower platforms completely, turn main switch off ("OFF" position) and lock it.
2. Open the cabinet and Place the oil drain pan under the hydraulic oil



9.6 Repair work (Repairs)



DANGER

If repairs are carried out incorrectly, they may cause serious injury and also lead to damage to property. A safety risk as well as a risk of fatal injury exists during operation.

- ➔ Repairs may only be carried out by trained customer service staff.
 - ➔ Follow all safety regulations and warnings in this chapter.
 - ➔ Always follow the repair instructions below. Repair work must be documented (→ Annex, inspection logbook).
- Always refer to the information received during the manufacturer's training.**

Changing the cylinder or seal kit.

Before removing cylinder make sure you have the correct seal kit or cylinder(see-Annex).

Cylinder Removal Procedure

3. Replace the hydraulic oil tank in the correct manner.
 4. Fill approved hydraulic oil up to the "max"-mark. Maximum capacity of empty tank.
 5. Bleed the cylinders both platforms.
 6. Close the cabinet and Remove oil residues on the floor or on the lift with an approved detergent. Dispose of used cleaning cloth in the correct manner.
 7. Turn main switch back on ("ON" setting).
 8. Check that control buttons and switches function properly.
 9. Carry out function tests with and without load.
 - 10 Complete maintenance report (→ Annex).
- 1) Raise the lift to the top and rest the platforms or scissors on the obstacle.
 - 2) Check to make sure the platforms or scissors is secure on obstacle.
 - 3) Check to make sure the platforms or scissors is secure on obstacle.
 - 4) Make sure the pressure has been relieved from the system.
 - 5) Follow the proper LOCKOUT/TAGOUT procedures for disconnecting power to lift.
 - 6) Disconnect the swivel hose fitting at base of cylinder.
 - 7) Disconnect the shaft at top and base of cylinder.
 - 8) Cap hose ends and cylinder adapter to prevent fluid loss.
 - 9) Carefully remove cylinder from scissors.

Cylinder Rebuilding(for changing the seal kit)

- 1) Remove manual bleeder and extend plunger from casing.
- 2) Remove piston retaining ring or clip.
- 3) Remove plunger from casing.
- 4) Clean inside of casing, making sure all debris is removed with mineral spirits.
- 5) Inspect seal for damage.
- 6) Replace seal and all other components (wiper, wear ring, etc.).
- 7) Coat seal with oil or white grease.
- 8) Reinstall plunger, retaining ring, and manual bleeder being careful not to scratch or dent plunger surface.

Cylinder Replacement

- 1) Reinstall cylinder and reconnect hose fitting and shafts.
- 2) Reconnect power source.
- 4) Raise cylinder until platformas or scissors out off the obstacle.take off the obstacle.
- 5) Lower both platformas.
- 6) Carefully raise carriages about two feet. Bleed air from both cylinders.
- 7) Fully lower lift.
- 8) Check and add fluid as necessary.
- 9) Raise lift to full rise and check for leaks.
- 10) Tag lift back in service.

10. Transport, Storage



Crushing and shearing hazard for limbs when unloading. Caused by collapsing or slipping of the load.

- ➔ Only unload the packing unit and transport to the installation site with a forklift truck or pallet jack with a sufficient load capacity.
- ➔ Only use hoists approved for the total weight (straps, chains etc.).
- ➔ Attach these so that the load cannot slip(check the center of gravity of the load).
- ➔ Only secure individual components to loadbearing parts. Always lift vertically, steadily and without jerking.
- ➔ Carry out a visual inspection before offloading.
- ➔ Do not stand close to or underneath swinging loads.
- ➔ Constantly monitor the danger zone when lifting or lowering. Always transport hydraulic components empty of oil.

10.1 Transport

The lift is supplied in a packing unit (base unit) plus a separate control cabinet . The packing unit comes with the following documentation:

- Transport description giving suitable suspension points, total weight, centre of gravity, required cable lengths, transport locks, etc.
- List of all individual components included in delivery.

10.2 Offloading

1. Inspect the shipment for any shipping or transport damage. Immediately report any damage to your supervisor and to the transport firm.
2. Transport the packing unit to the installation site. This must conform to the approved environmental conditions (→ Chapter 7. Technical data).
3. Unfasten the transport locks for the large parts on the front of the packing unit.
4. Offload the base lift and control cabinet and set down carefully.
5. Remove all other components from the pallet and set down carefully.
6. Inspect the supplied parts according to the packing list provided.
7. Dispose of packaging in an environmentally friendly manner, in compliance with the regulations applicable in your country (→ Chapter 16. Disposal).

10.3 Storage

Lift components must always be stored in a dry place (no corrosion protection).

Recommended Storage Conditions

- Ambient temperature: -5 ... +50
- Relative humidity, with condensation, at 20 °C 30 % ... 95 %



The manufacturer provides no warranty for corrosion damage caused by incorrect storage.

16

Base lift package



Control cabinet with power unit package

11. Assembly(installation)



DANGER

Incorrect installation work may lead to serious injury and material damage. A safety risk as well as a risk of fatal injury exists during operation.

- ➔ Follow the instructions below carefully.
- ➔ Only customer service staff authorized by the manufacturer may assemble and commission the scissor lift.
- ➔ Correct installation and commissioning must be documented in the inspection logbook. To do so, use the form "Initial safety inspection before installation".

11.1 Assembly safety instructions

- Verify that the foundation is suitable before assembling.(→ Chapter 7 Technical data.)
- Think about and prevent potential sources of danger before assembly (→ Chapter 1. Intended use, improper use, incorrect behavior, and internal incident, health & safety, and environmental information).
- Operators must be able to view the scissor lift and the danger zone in full from the control unit (→ Chapter 3.2. Work area, danger zone).
- Refer to the technical data in chapter 7.
- Route and protect on-site power cables according to manufacturers specifications.
- Only qualified electricians may carry out electrical work on the electrical equipment of the machine.
- Only qualified staff with specialist knowledge and experience with hydraulics or pneumatics may work on hydraulic or pneumatic equipment.
- When working on the hydraulics or on pneumatic equipment, ensure that you follow the safety regulations listed in the supplied power unit operating instructions annexed to this manual.
- **Ensure that you also follow the instructions listed in 2. Safety.**

11.2 Site specifications

- The scissor lift may only be installed above ground and indoors.
- Refer to the building plans when selecting a site.
- When anchoring to the floor, take into account any pipes, cables, and supply lines lying there.
- Ensure that the load capacity of the foundation is adequate.
- Support surface for lift base frame:
Reinforced concrete, concrete quality C20/C25
- Floor must be designed for a floor anchor.
- Concrete dimension .(→ Chapter 7 Technical data.)
- Check the height of the area where the lift is to be installed. Clearance should be calculated based on the full raised height of the lift and the height of the tallest vehicle being lifted.



Do not fit scissor lift onto asphalt or a similar unstable surface, since the anchor may come loose in the floor.

- Comply with the specified minimum distances and clearances (→ Chapter 3.2. Work place, danger zone)

11.3 Installation preparations

1. Provide an electrical outlet close to the lift control cabinet:
 - Electrical, according to the lift variant :
3 ph (3xL+PE) for power unit motor
1ph (L+N+PE) for power unit motor..
see electric wiring diagram in annex.
2. Level out any uneven floor areas around the lift columns. If required, fill bearing surfaces for lift columns with reinforced concrete (concrete quality C20/C25).
3. Equalize slight differences in height between lift base frame using spacers or shims.

11.4 General lift location

1. Use architects plan when available to locate lift. see Chapter 7 Technical data.
2. Control cabinet may be placed on the left or right.
3. Place platforms and control cabinet as shown in Fig. 17 for surface mount or flush mount applications.

DO NOT anchor any components at this time.

The control cabinet should be located on the opposite end of vehicle approach, as shown in Fig. 17. Operator should be in a position to notice any misalignment of lifting pads or vehicle during operation. Rotary Lift does not recommend placing the control cabinet in a different location orientation and doing so would be the responsibility of the installer and/or end user.



Relocating the control cabinet further away than the standard distance will require the installer to provide suitable hydraulic hoses. Additional hose covers will also be needed if installing the control cabinet at a further distance than the standard distances in surface mount configurations. Hydraulic hoses should be 6mm min. ID with a min. working pressure of 5800 psi (400 Bar) with #6 JIC Swivel Female fittings. Extension Hose Kits available.

11.5 Control Cabinet Connections

● **Electrical Connection:**

Have a certified electrician run appropriate power supply to motor wire size for a three phase 400V with 16 amp \ three phase 220V with 25 amp or single phase 32 amp. circuit.

- Never operate the motor on line voltage less than 208V. Motor damage may occur.

All wiring must conform to all national and local electrical codes.



WARNING

Make sure that the main power supply is disconnected to avoid the possibility of electrocution.

- Connect the limit switch wires to PCB on control cabinet ,fig 18.
- .Verify the power connection on the control cabinet connections are complete and correct base on the wiring schematic (see annex) and motor connection .fig19.
- Connect to power supply line.



CAUTION

Control cabinet should always be oriented so operator is facing the direction of the lift when operating the lift.

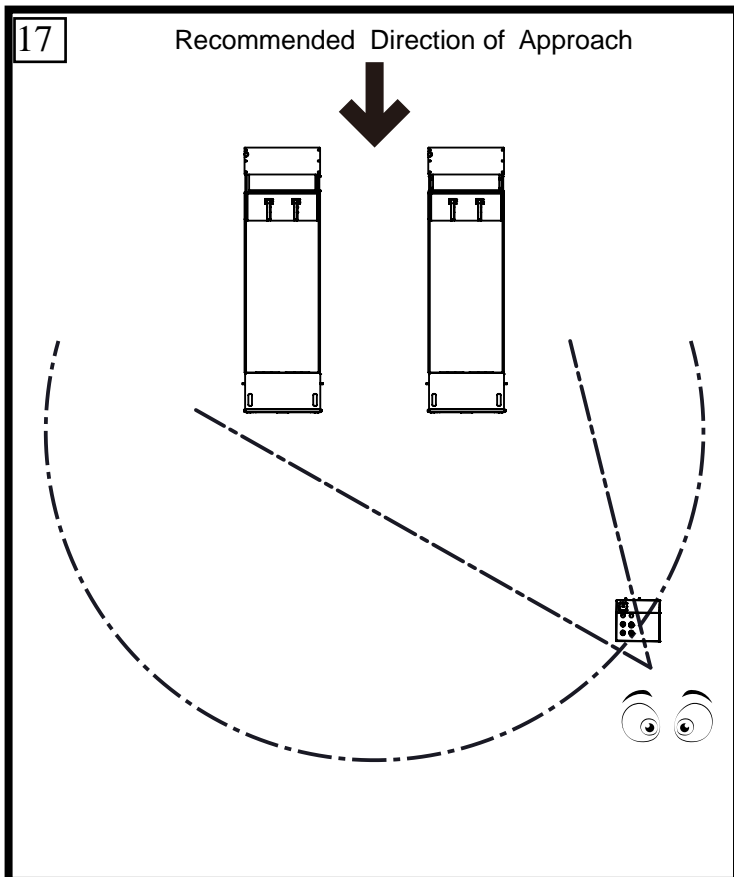

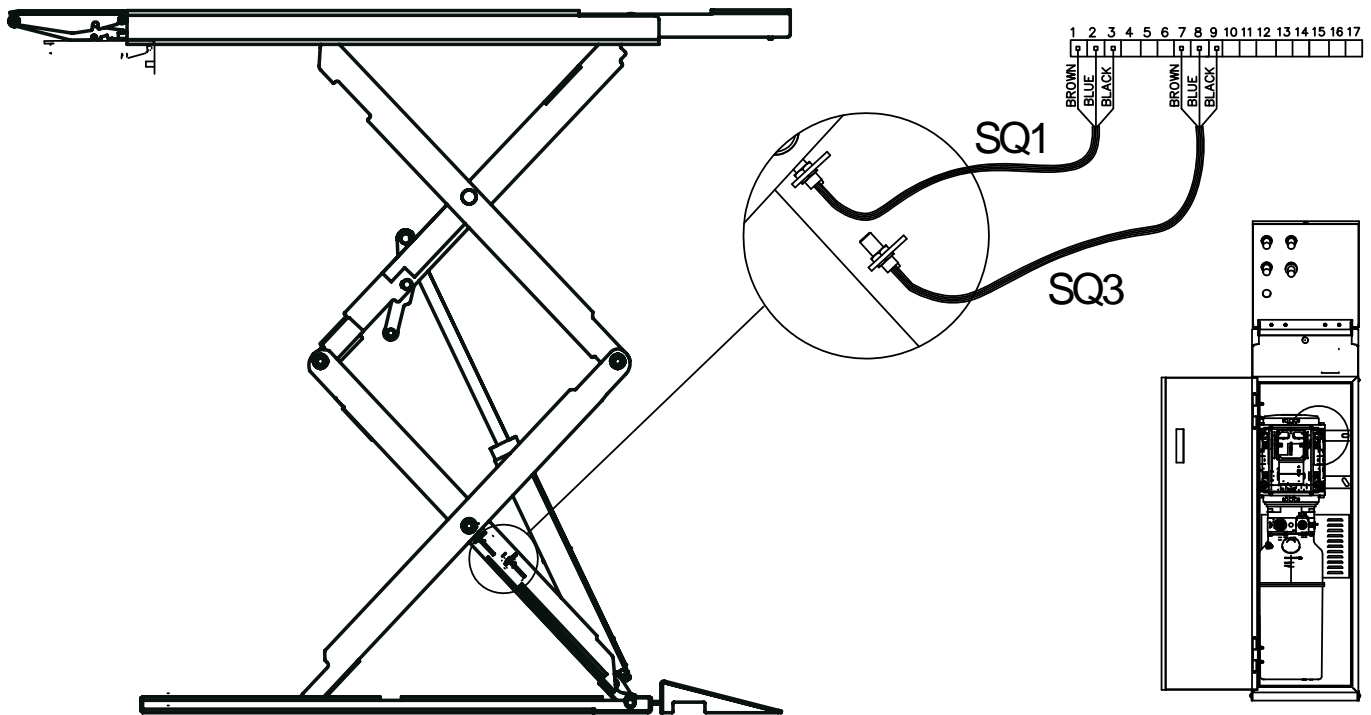

Connect One Platform Top Limit Switch and Stop Down Switch

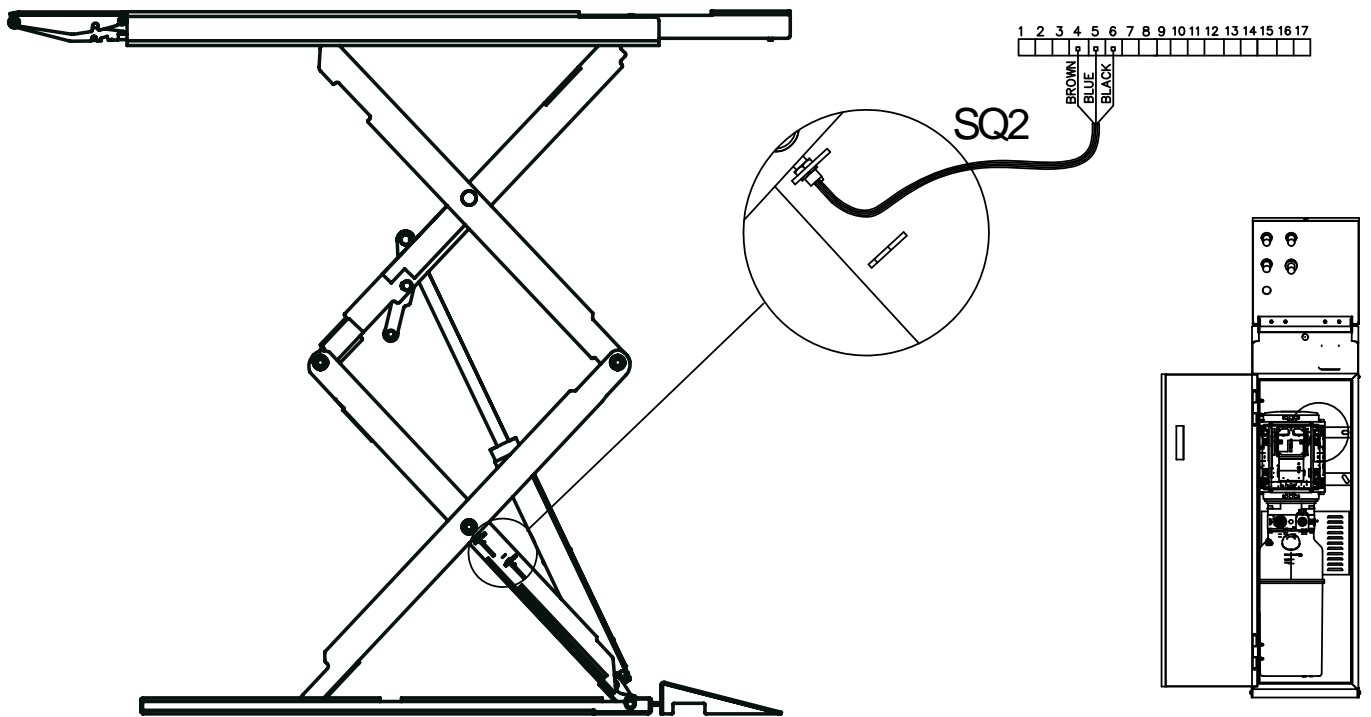

Connect One Platform Top Limit Switch

Transformer

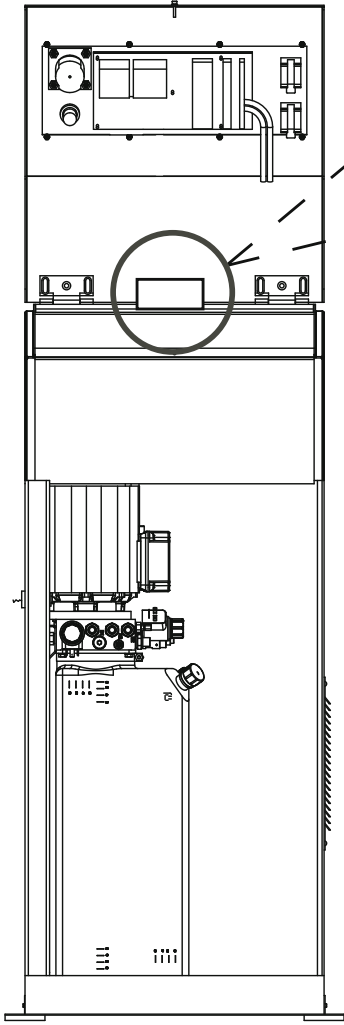
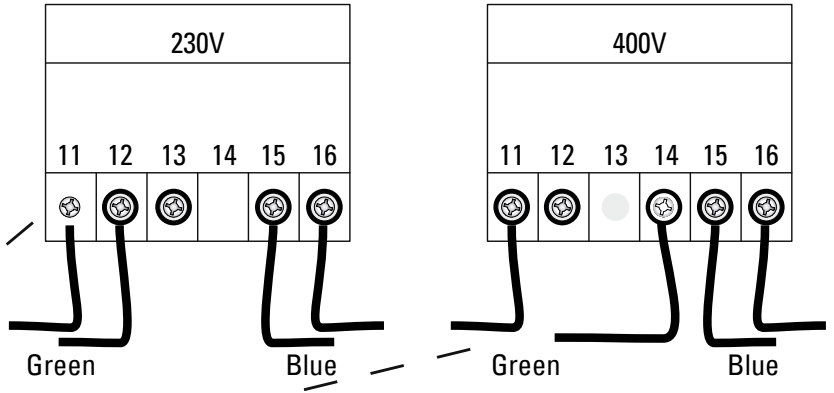

11.6 Oil filling ,bleeding,hose connection

Use **Approved hydraulic oils** (see 9.4) .
Remove fill breather cap and add (10) ten quarts of fluid. Turn power to on and ensure the disconnect switch and emergency stop buttons are in the “ON” position. Proceed with the following steps.

⚠WARNING Only skilled and authorized personnel should be allowed to perform these operations. Carefully follow all instructions shown below to prevent possible damage to the car lift or risk of injury to people.

Be sure that the operating area is cleared of people. After positioning the lift as specified and performing electric and hydraulic connections, the lift can be operated by following the specific procedure.

1. Verify both top limit switches and stop down switch electrical connections are complete, as shown in Fig. 18 and Fig. 19.
2. Connect hydraulic hoses “A” and “B” to the power unit as shown in Fig. 20.

3. Push the “UP” button until both platforms stop moving.
4. Add 5 liters more of fluid.
5. Connect the uninstalled hydraulic hoses marked “C” and “D”, as shown in Fig. 20.
6. Connect the uninstalled hydraulic tube, as shown in Fig. 20.
7. Push the “UP” button until both platforms stop moving.
8. Open the cabinet lid and press the “Override UP” button, as shown in Fig. 21, and HOLD FOR APPROXIMATELY 40 SECONDS.
9. Close cabinet lid and lower platforms to the ground.

If lift does not raise but the motor runs, check the motor for proper direction of rotation and switch the phases on the power supply line if necessary.

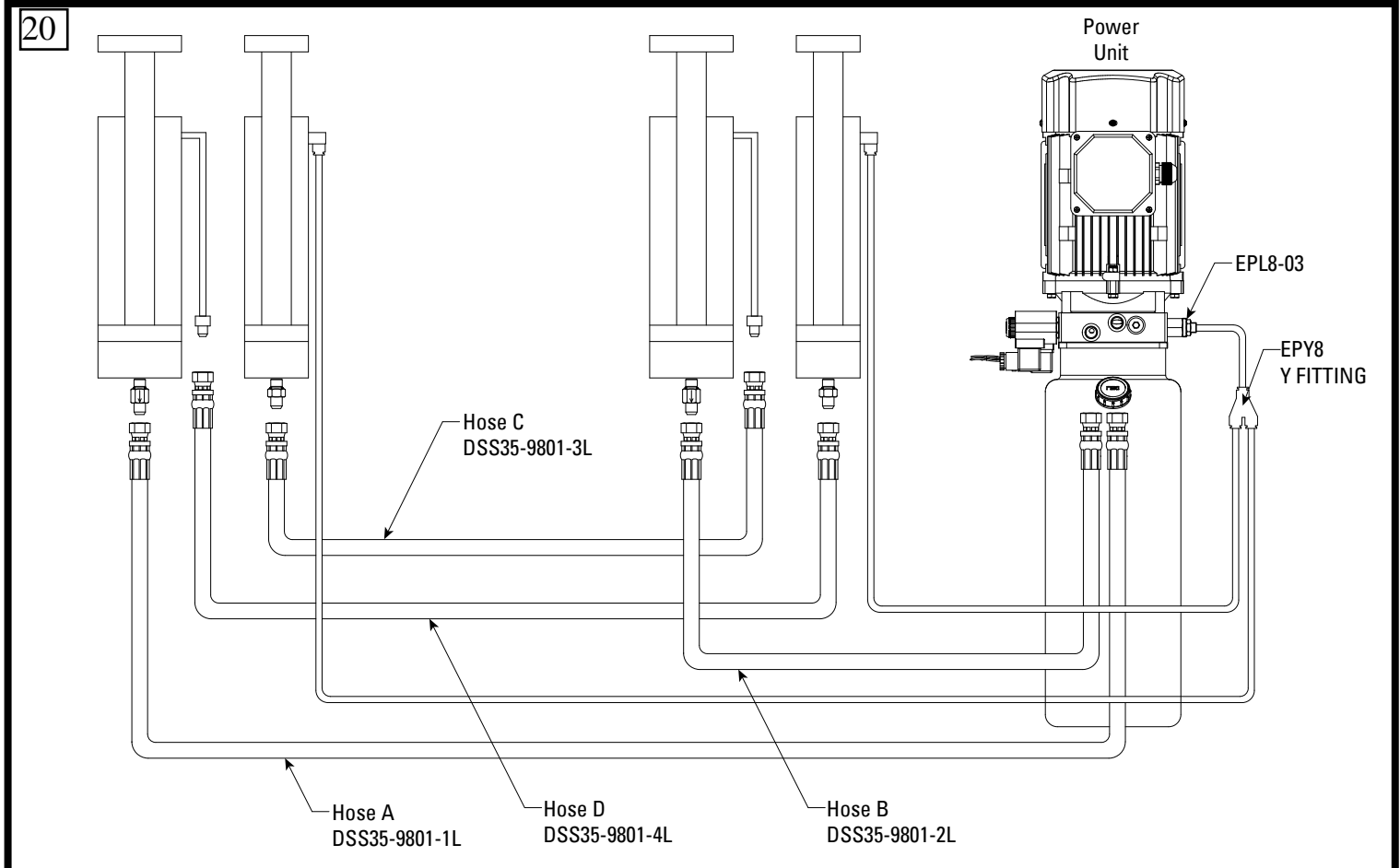



Make sure the platforms or scissors can not fall down when you work under the platforms.

11.7 Final Positioning of Platforms

1. Verify the platform bases are square and the distance between the platforms is correct.
2. Verify platform bases are level, Fig. 22
3. Verify platform bases are level to each other, Fig. 22.
4. Verify both platform bases are level front to rear, Fig. 23.
5. Verify platforms are level, Fig. 24.
6. Verify platforms are level to each other, Fig. 24.

21



23

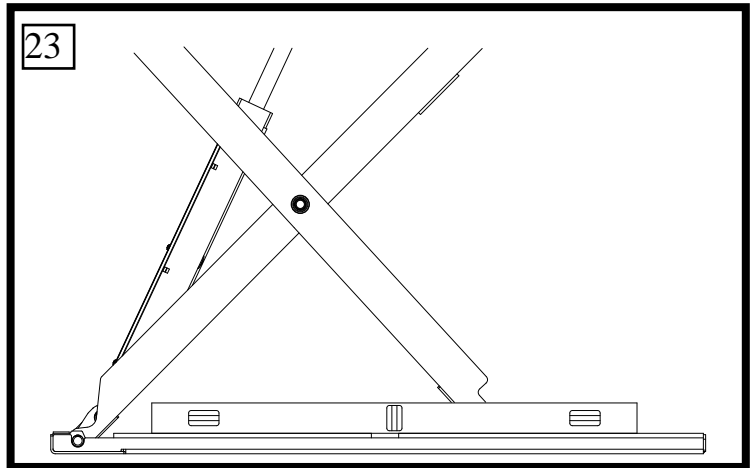

22

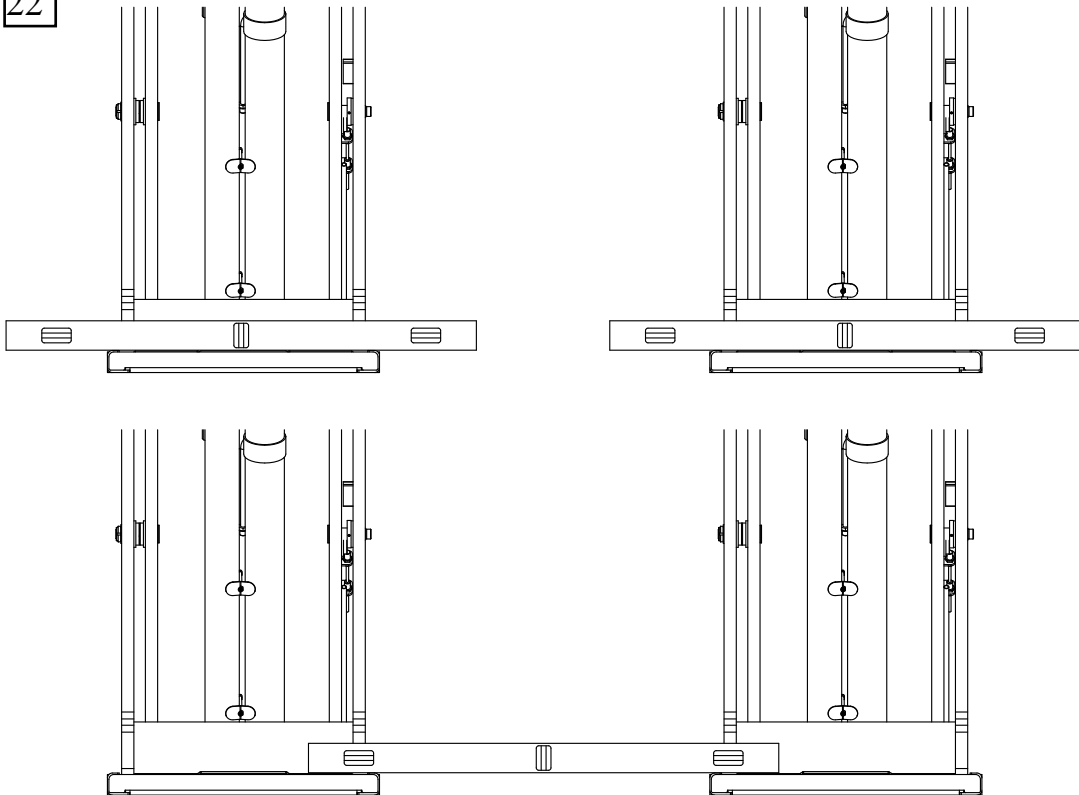

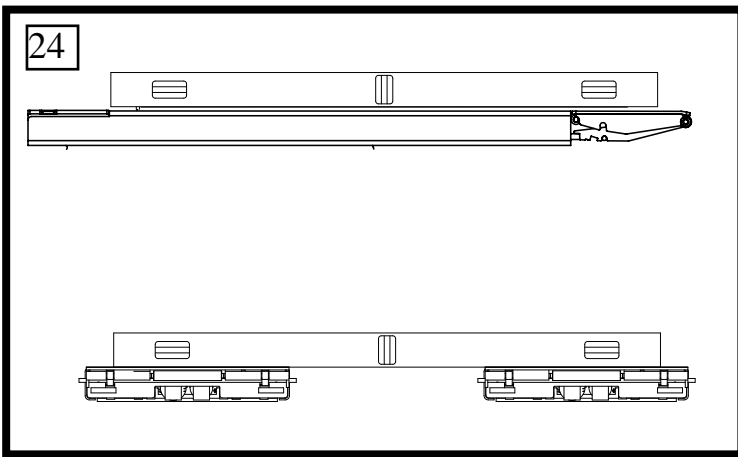

11.8 Anchoring

1. Turn the disconnect switch to “ON” and press the “UP” button to raise the platforms which provides room under the platforms for drilling.
2. Concrete shall have a compression strength of at least C20/25 and a minimum thickness of 160mm. Drill (8) holes with required diameter in the concrete floor and install (8) eight lift anchors loosely. Do not tighten.
3. Complete leveling measurements described under item number 11.4.
4. Shim as necessary, Fig. 25, and tighten anchors.
5. Grout if necessary.
6. Re-check for levelness.



WARNING

Do not install this lift without anchoring to required specifications. Failure could result in personal injury or death.

25

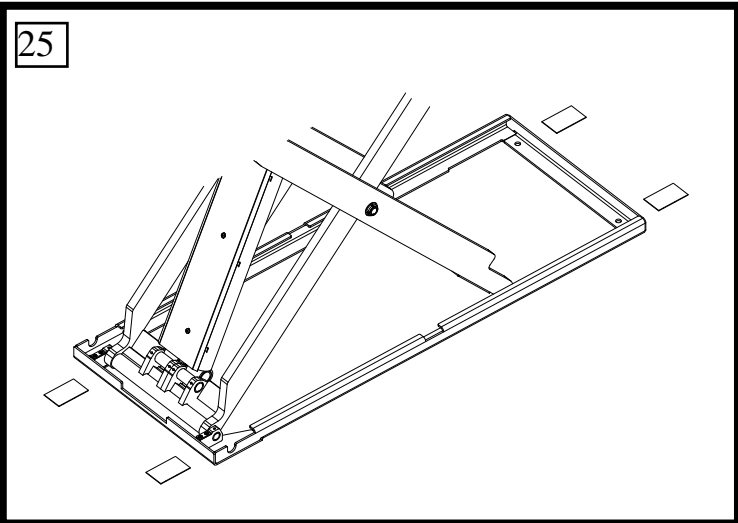

26

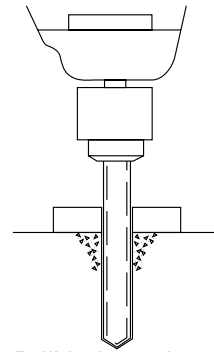

Drill holes using correct carbide tipped masonry bit drill bit.

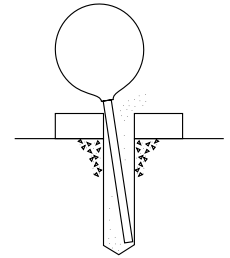

Clean Hole

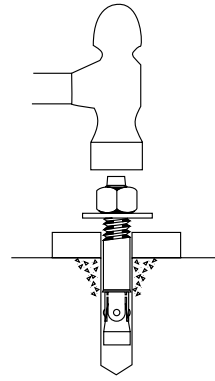

Run nut down just below impact section of bolt. Drive anchor into hole until nut and washer contact base.

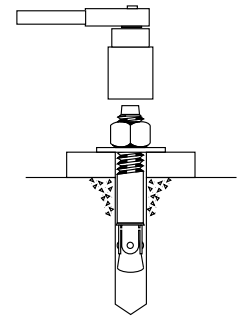

Tighten nut with torque wrench. For chemical anchor bolts read the manual of the anchor manufacturer.



WARNING

If the floor is not level the platforms will not be level which could result in unsatisfactory lift performance, property damage, or personal injury.

11.9 Hose Covers and Anchoring(surface mounted)

- Position hose covers as necessary per control cabinet location. Use provided anchors to fasten all hose covers securely, Fig. 27.

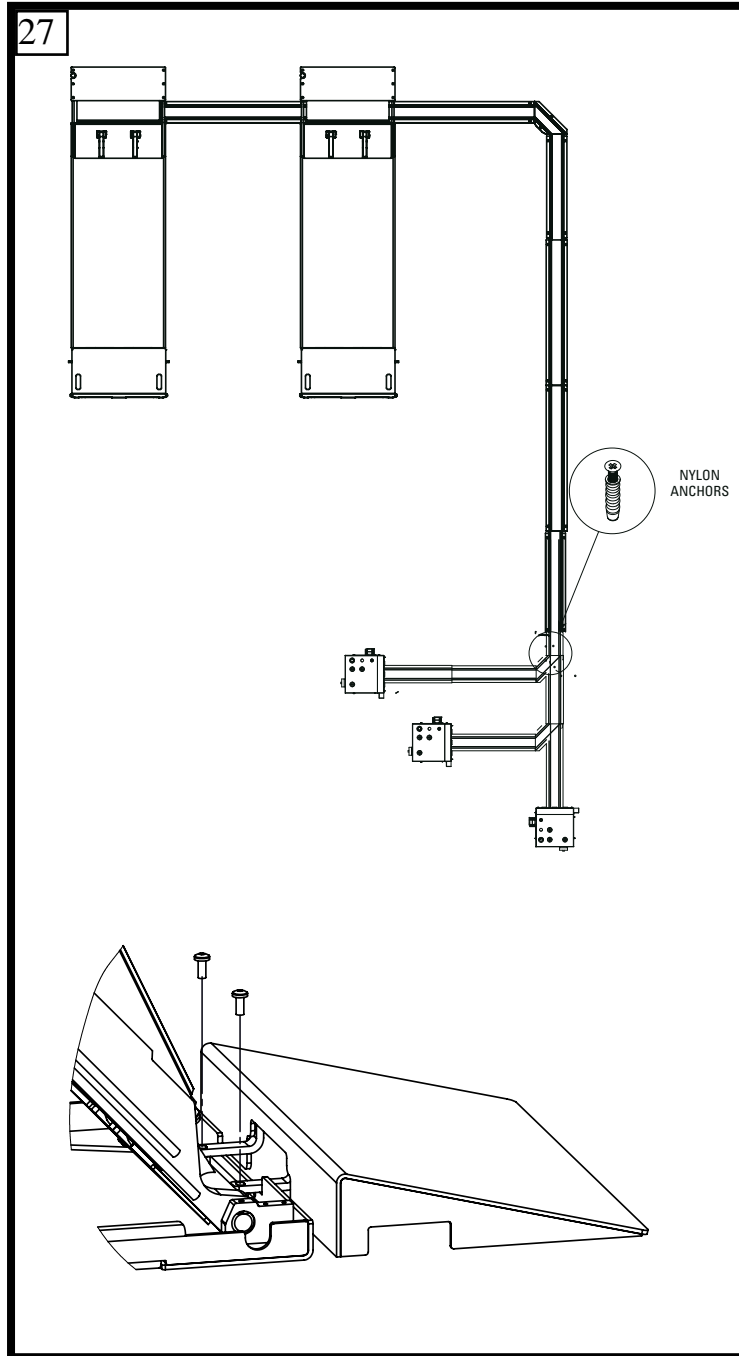

11.10 Flush Mount Pit

- Prior to pouring concrete, installer will need either the Full Flush Mount Kit (part # XX100025) or Recess Box Flush Mount Kit (part # XX100024). Please contact the phone number listed on the front cover of the manual for additional assistance. The Full Flush Mount Kit contains frame components with concrete ties that will need to be placed during concrete pour. See parts breakdown manual for included components. Pit forms are not provided and will be the responsibility of the installer.
- Bend frame anchors outward, perpendicular to angle frame, and downward approximately 45° to floor level, Fig. 28.
- Place the recess box in the pit and install M8 bolts to secure to frame and anchors to pit floor. If recess weldment is not used, fasten recess box using anchors only, Fig. 29. Install hose cover to recess box using M8 bolts and anchors to pit floor, Fig. 29.
- For flush mount pit specifications, see section 7. Technical data.

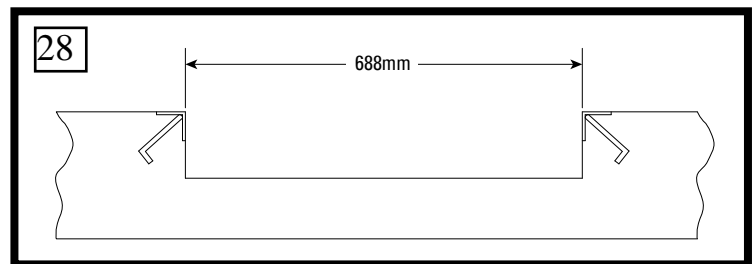

29

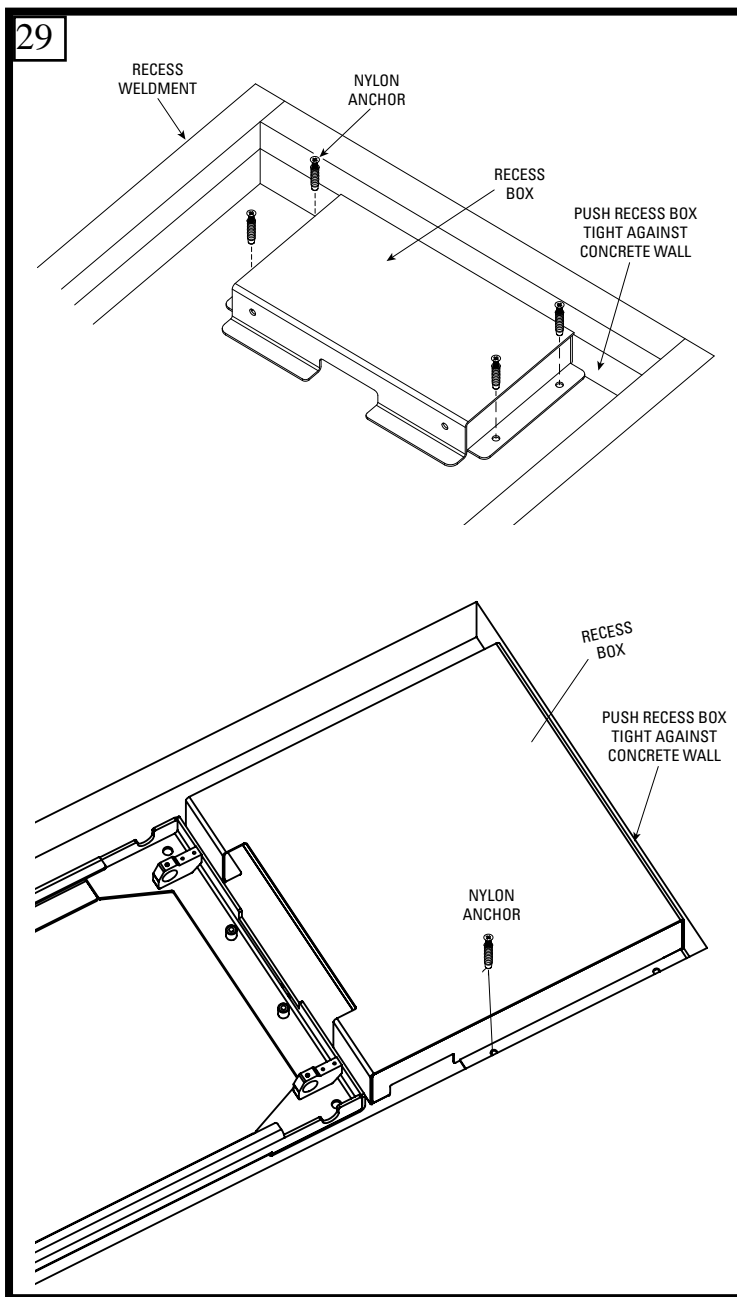

11.11 Adjust Cushion Device

1. To adjust platform height in down position, use cushion screws (3), Fig. 30.
2. Cushion screws extending through cushion weldment (1), Fig. 30, too far will result in platform not lowering completely to the floor. Cushion screws not extending through cushion weldment far enough will cause the platform to lower to the floor too quickly and the platform to hit the frame too hard. (This will not damage the lift, but will be loud and may be disturbing to technicians.)
3. Once the cushion screws are adjusted properly, tighten lock nuts (2), Fig. 30.
4. Raise and lower lift once more to ensure screws are adjusted correctly.

30

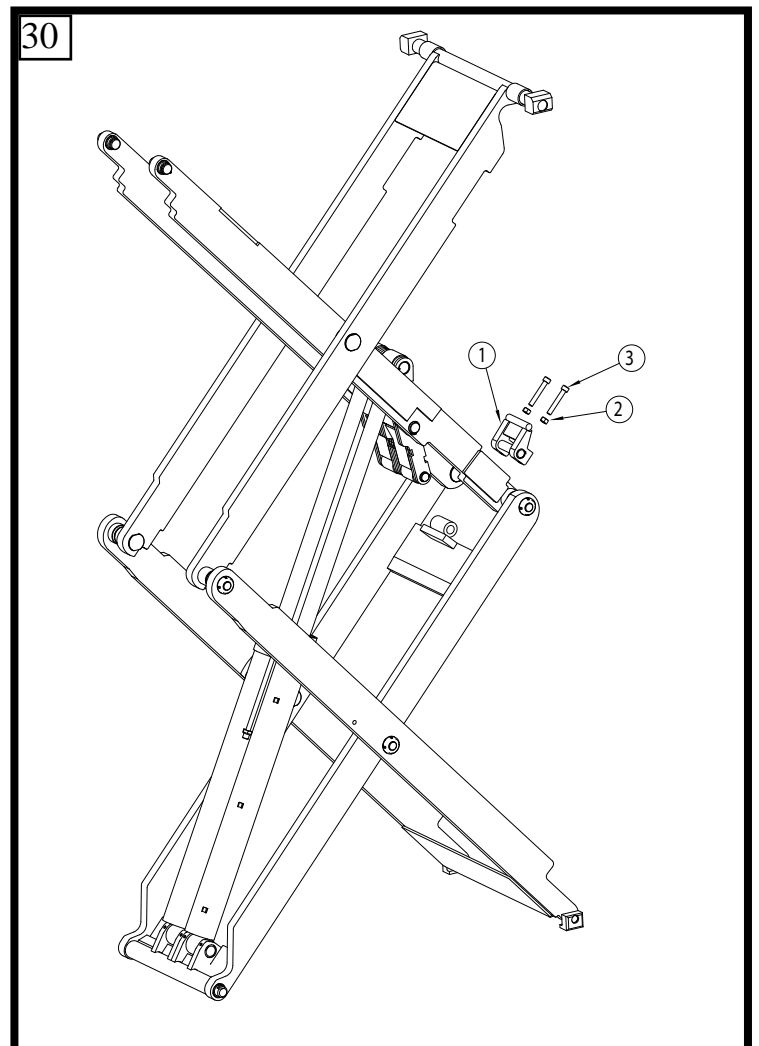

12. Commissioning

12.1 Check Operation

Operate lift and assure that push button raises lift when pushed and stops lift when released. Check disconnect switches for cutting power to push-buttons. Also check that Proximity switch stops lift from raising and lowering when actuated and that lift regains power when deactivated.



Lubricate the surface of slide between the top platform and base frame before commissioning. It can be applied by brushing. This can significantly increase the service life of the lift.

12.2 Test the hydraulic system

1. Set the main switch to ON.
2. Move the unloaded lift to full rise and the bottom position several times using the Up and Down buttons. This will completely remove any air pockets in the hydraulic system.
3. Press up button to raise lift to full rise and keep motor running for 5 seconds. Stop and check all hose connections. Tighten or reseal if required.
4. Carry out a visual inspection of the hydraulic and pneumatic system. In doing so, check all lines, especially the couplings. No leaks must be found.
5. Lower the lift completely and check the hydraulic oil level. This must also correspond to the maximum level.
6. Finally check that the hydraulic components are fitted securely.

13. Disassembly

- Disassembly work may only be carried out by authorized qualified staff.
 - Only qualified electricians may work on the electrics.
 - Only trained persons with specialist knowledge of hydraulics/pneumatics may work on the hydraulic or pneumatic equipment.
1. To carry out disassembly work, switch off the equipment at the main switch (position OFF).
 2. Attach a warning sign to prevent reconnection.
 4. Disconnect the electricity supply.



WARNING

Risk of fatal injury through incorrect disassembly of hydraulic components. These are pressurized (up to 200 bar).

- ➔ Never disassemble hydraulic components (lift cylinders). These should always be detached as a single component.
- ➔ The lift cylinder should only be properly disposed of by a certified company.

5. Empty the hydraulic oil tank, drain the hydraulic oil from the hydraulic hoses. Dispose of the hydraulic oil as described in Chapter 14.
6. Remove grease and other chemical substances. Dispose of as described in Chapter 14.
7. Disassemble lift columns, cross beams and arms

14. Disposal

14.1 Environmental procedures for disposal

- Prevent environmental hazards.
- Avoid contact with or inhalation of toxic substances such as hydraulic fluid.

- Oils and lubricants are water pollutants under the terms of the Water Management Act WGH. Always dispose of these in an environmentally friendly manner in compliance with the regulations which apply in your country.
- Hydraulic oil-based on mineral oil is a water pollutant and is combustible. Refer to the relevant safety data sheet for disposal.
- Provide suitable oil drain pans and oil absorbents to drain the oil.
- Ensure that no hydraulic oil, lubricants, or cleaning materials contaminate the soil or wash away into the drainage system.

14.2 Packaging

Do not dispose of with domestic waste! The packaging contains some recyclable material which must not be disposed of with domestic waste.

1. Dispose of packaging materials in compliance with local regulations.

14.3 Oils, grease, and other chemical substances

1. When working with oil, grease and other chemical substances, comply with the environmental regulations which apply to the relevant product.
2. Dispose of oil, grease and other chemical substances in compliance with the environmental regulations which apply in your country.

14.4 Metals / Electronic waste

This must always be properly disposed of by a certified company.



Dispose of used electrical and electronic devices, including cables, accessories and batteries, separately from household waste.

Annex

Scissor lift

DS35EX

Series 100

I. Hydraulic circuit diagram

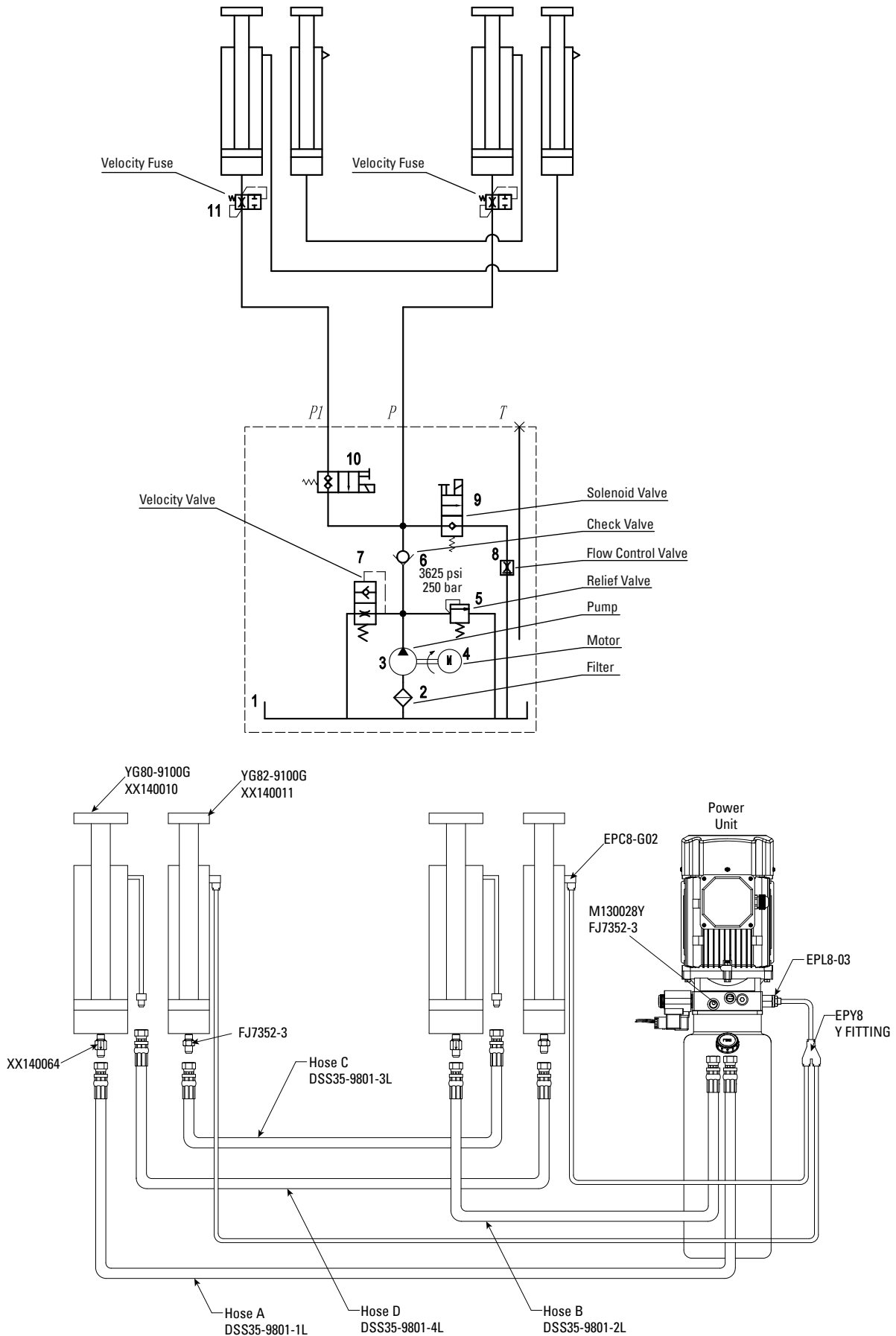

II. Electric wiring diagram

WIRING SCHEMATIC

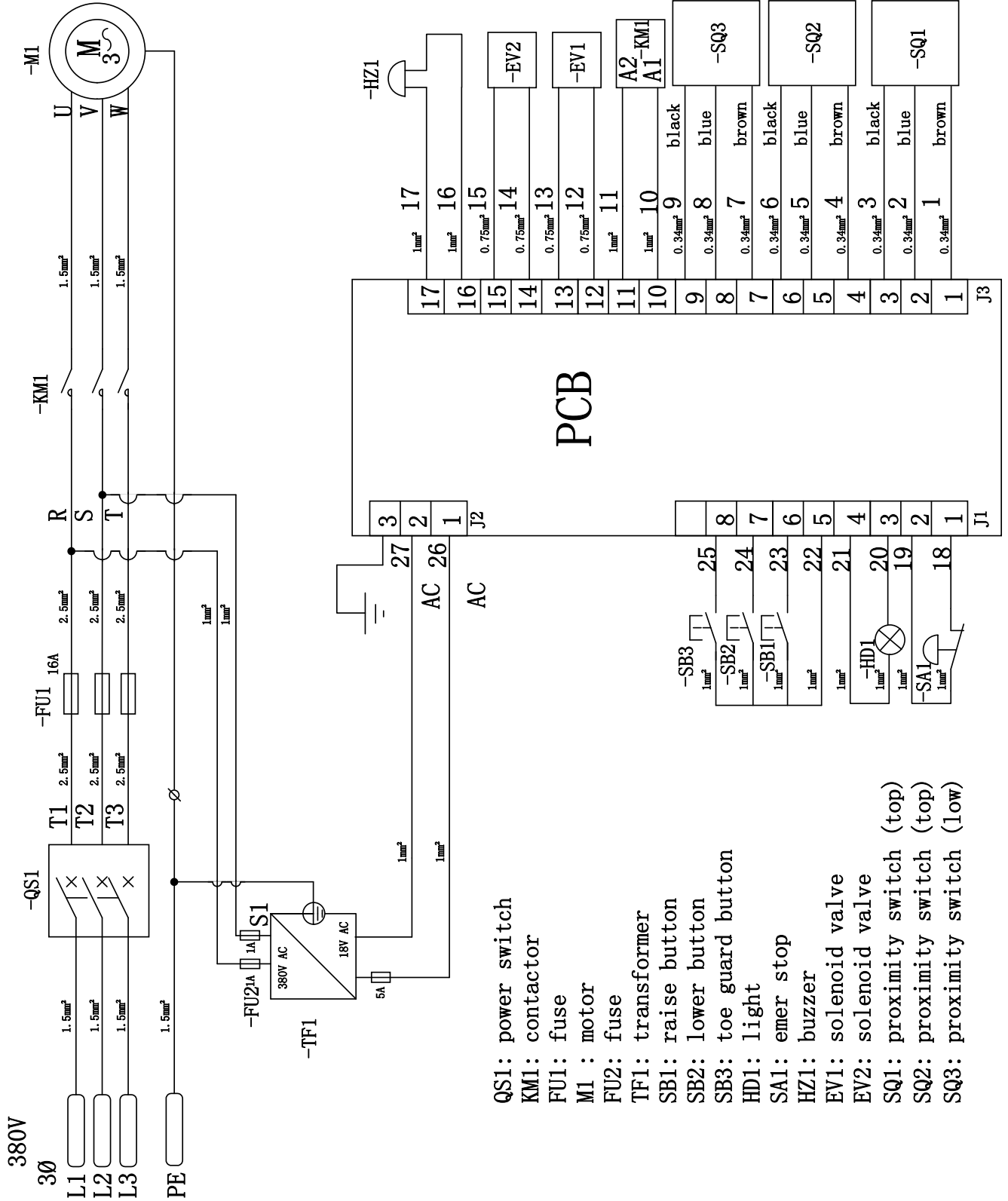

- QS1: power switch
- KM1: contactor
- FU1: fuse
- M1 : motor
- FU2: fuse
- TF1: transformer
- SB1: raise button
- SB2: lower button
- SB3: toe guard button
- HD1: light
- SA1: emer stop
- HZ1: buzzer
- EV1: solenoid valve
- EV2: solenoid valve
- SQ1: proximity switch (top)
- SQ2: proximity switch (top)
- SQ3: proximity switch (low)

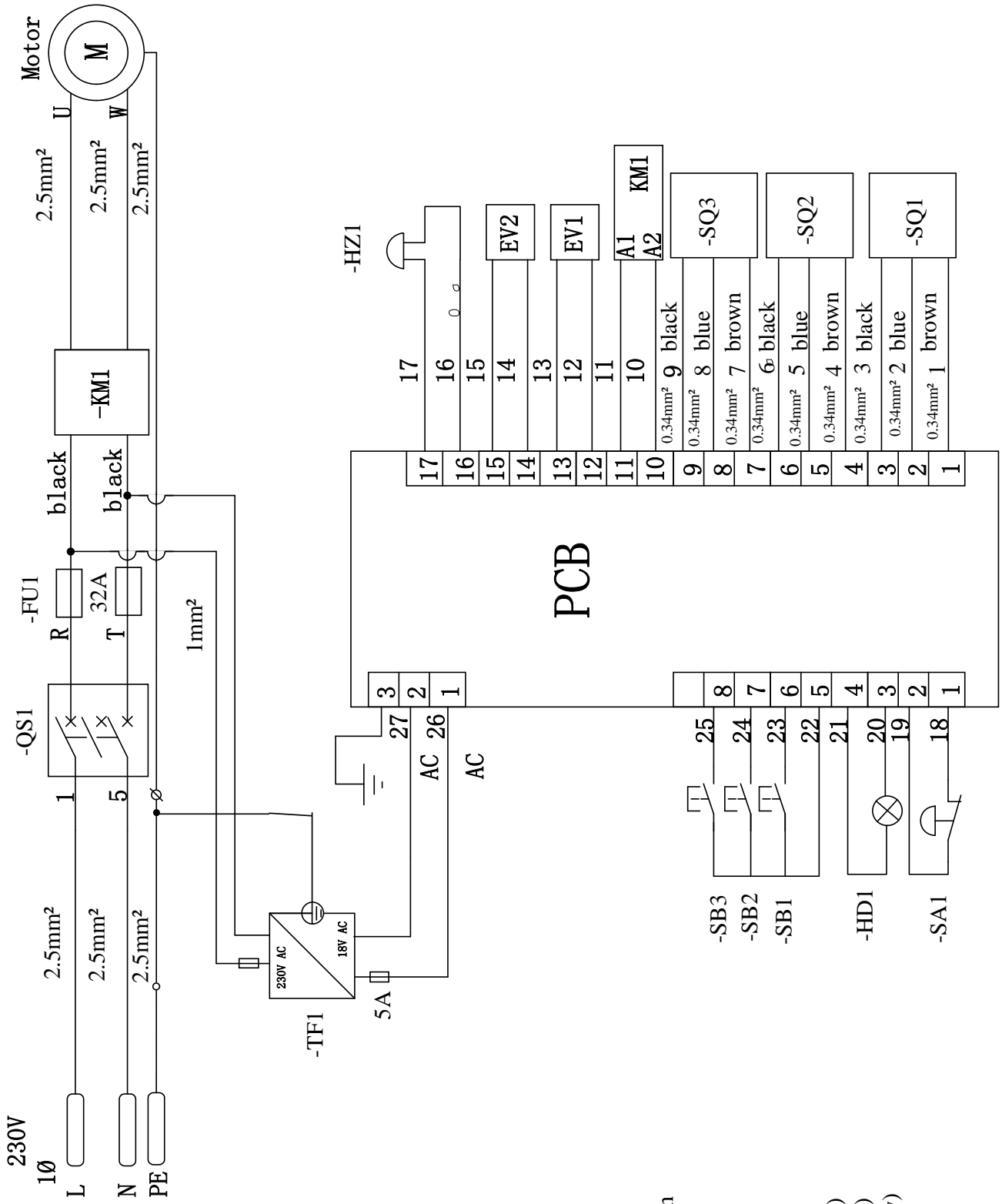

- QS1: Power Switch
- KM1: Contactor
- FU1: Fuse
- M1: Motor
- FU2: Fuse
- TF1: Transformer
- SB1: Raise button
- SB2: Lower button
- SB3: Lower to ground button
- HD1: Light
- SA1: Emergency stop
- HZ1: Buzzer
- EV1: Solenoid valve
- EV2: Solenoid valve
- SQ1: Proximity switch (Top)
- SQ2: Proximity switch (Top)
- SQ3: Proximity switch (Low)

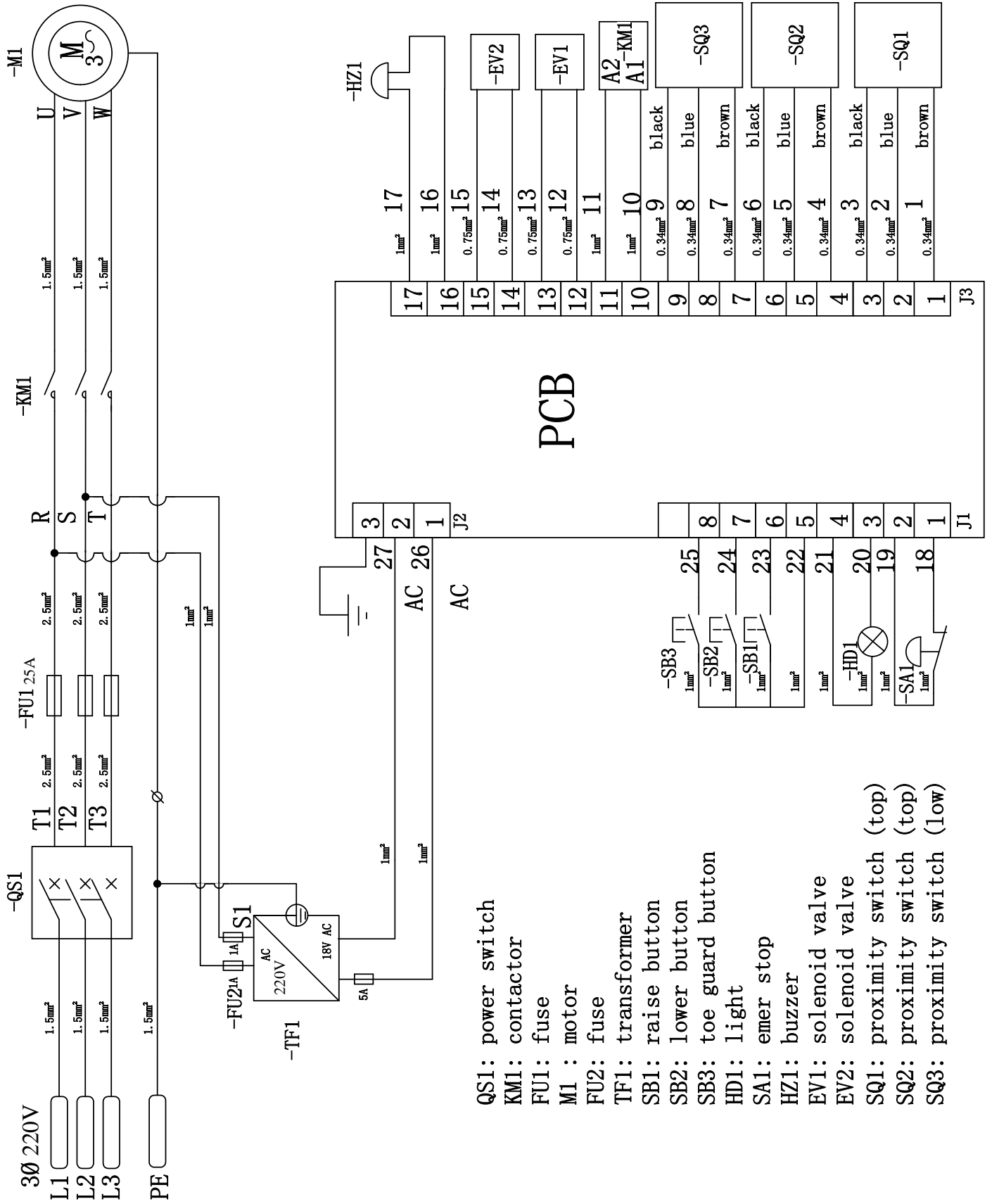

- QS1: power switch
- KM1: contactor
- FU1: fuse
- M1 : motor
- FU2: fuse
- TF1: transformer
- SB1: raise button
- SB2: lower button
- SB3: toe guard button
- HD1: light
- SA1: emer stop
- HZ1: buzzer
- EV1: solenoid valve
- EV2: solenoid valve
- SQ1: proximity switch (top)
- SQ2: proximity switch (top)
- SQ3: proximity switch (low)

Annex III. Parts Break Down

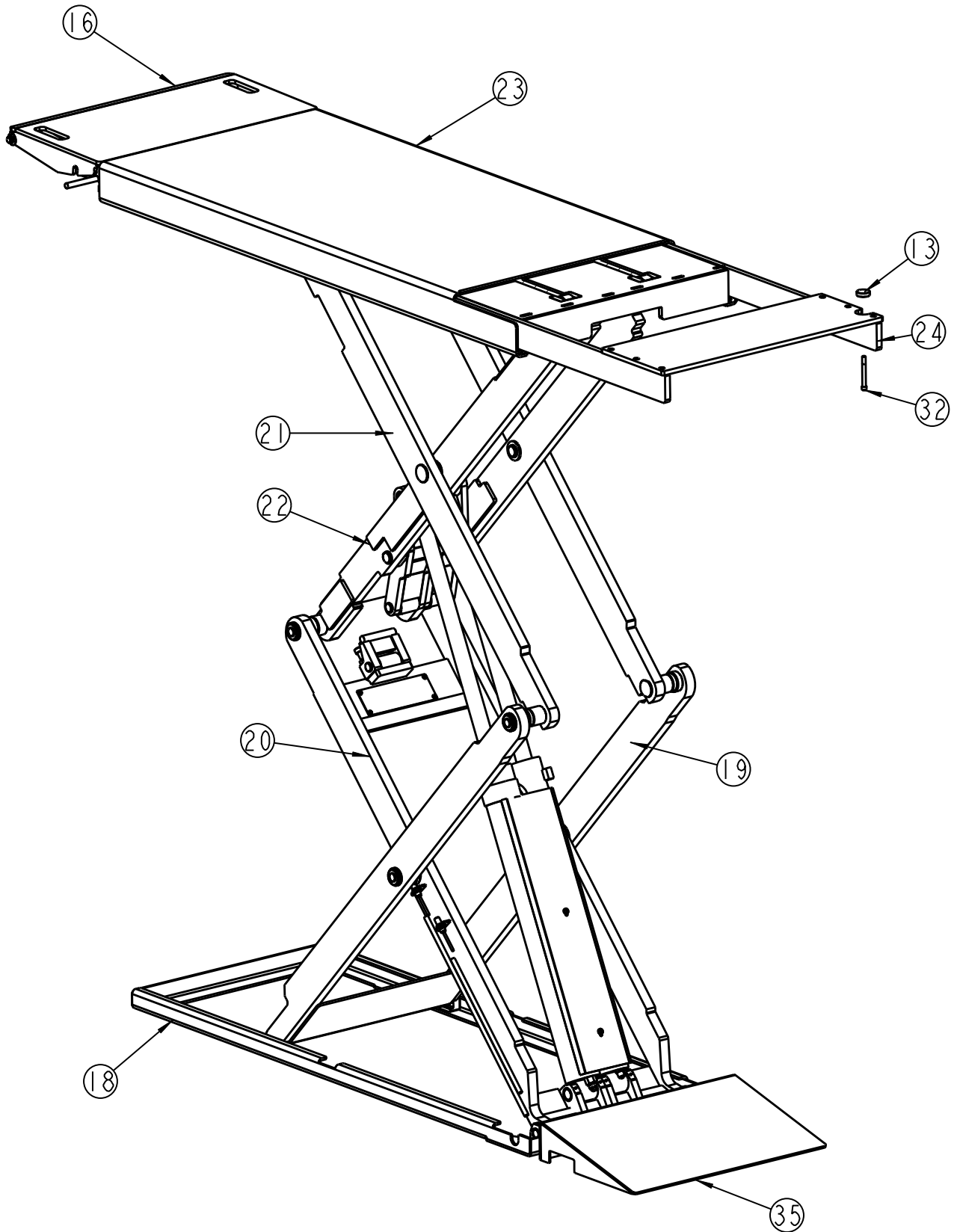

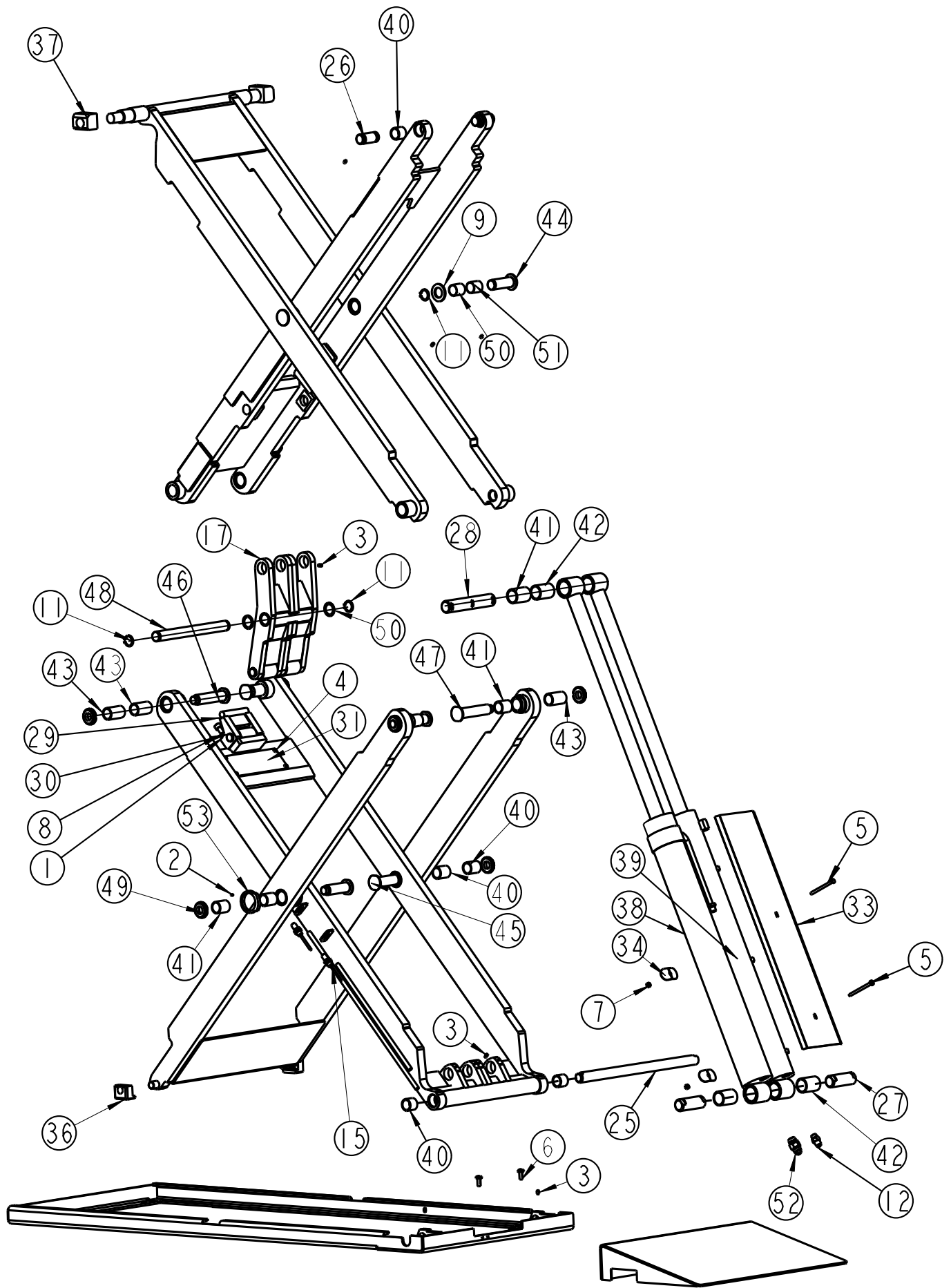

Detail for PB-DS35EX01			
	PartNo.	Description	Qty
1	B201-10*65	Hex socket head screw M10*65	4
2	B21-4*6	Hex socket set screw with flat pointM4*6	2
3	B21-6*10	Hex socket set screw with flat pointM6*10	14
4	B25-6*12	Hex socket pan head screw M6*12	8
5	B25-6*80	Hex socket pan head screw M6*80	4
6	B25-8*20	Hex socket pan head screw M8*20	4
7	B30-6	Hex NutM6	4
8	B30-10	Hex Nut M10	4
9	B41-24	Flat washer Φ24	4
10	B61-12	E ring Φ12	8
11	B63-25	Circlip Φ25	8
12	FJ7352-3	Fitting for cylinder	2
13	XG120028	Extension beam Handle	2
14	XG130044	M6*10 set screw-cone point	8
15	XG130075	Proximity switch	3
16	XX110003	Ramp assembly	2
17	XX11006	Kicker assembly	2
18	XX120002G	Base frame weldment	2
19	XX120003G	Scissor leg weldment	2
20	XX120004G	Scissor leg weldment	2
21	XX120005	Scissor leg weldment	2
22	XX120006	Scissor leg weldment	2
23	XX120014G	Platform weldment	2
24	XX120036G	Extension beam (Picture show)	1
	XX120013G	Extension beam (do not show)	1
25	XX130080	Pin long	2
26	XX130081	Pin long	4
27	XX130082	Lower cylinder pin	4
28	XX130086	Upper cylinder pin	2
29	XX130210	Cushion weldment	2
30	XX130214	Pin	2
31	XX130225	Stainless plate	2
32	XX130226	Beam stop bolt	2
33	XX130232	Cylinder cover	2
34	XX130233	Connect plate	4
35	XX130261	Base ramp weldment	2
36	XX140007	Slider block (lower)	4
37	XX140008	Slider block(Upper)	4
38	XX140010	Cylinder	2
39	XX140011	Cylinder	2
40	XX140014Y	Bearing 25dia*25 long	8

41	XX140015Y	Bearing 25 dia*35 long	12
42	XX140017Y	Bearing 30 dia*50 long	8
43	XX140019Y	Bearing 25 dia*50 long	12
44	XX140021	Pin	4
45	XX140022	Pin	4
46	XX140023	Pin	4
47	XX140024	Pin	4
48	XX140025	Pin	2
49	XX140028	M20*1.0 slotted round lockunt	12
50	XX140029	Wahser	4
51	XX140062	Bearing	8
52	XX140064	Velocity valve	2
53	XX140066	Sensor block	1

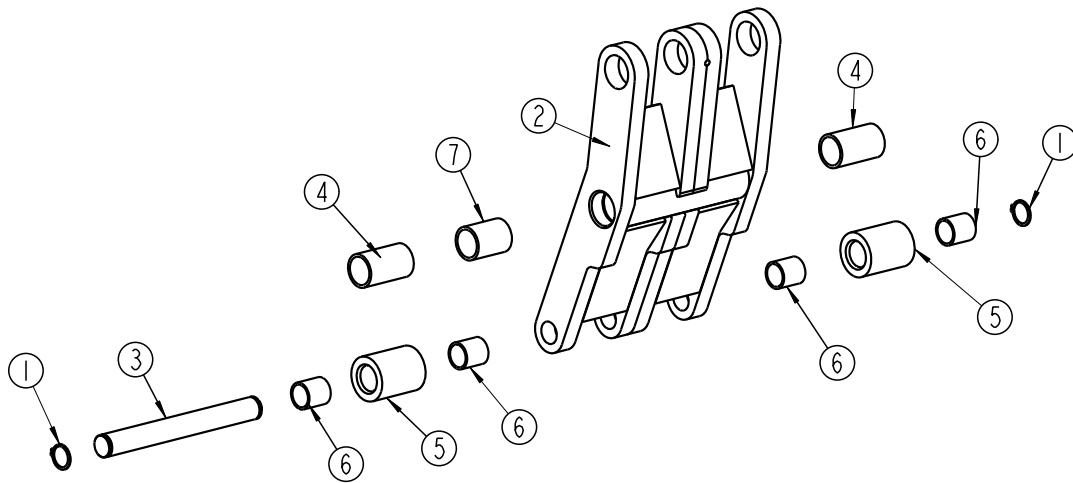

Detail for XX110006 Kicker assembly			
	PartNo.	Description	Qty
1	B60-20	Circlip Φ 20	2
2	XX120020	Kicker weld	1
3	XX130036	Roller pin	1
4	XX140019Y	Bearing 25dia*50long	2
5	XX140035	Roller	2
6	XX140061	Bearing 20dia*25long	4
7	XX140067Y	Bearing 25dia*65long	1

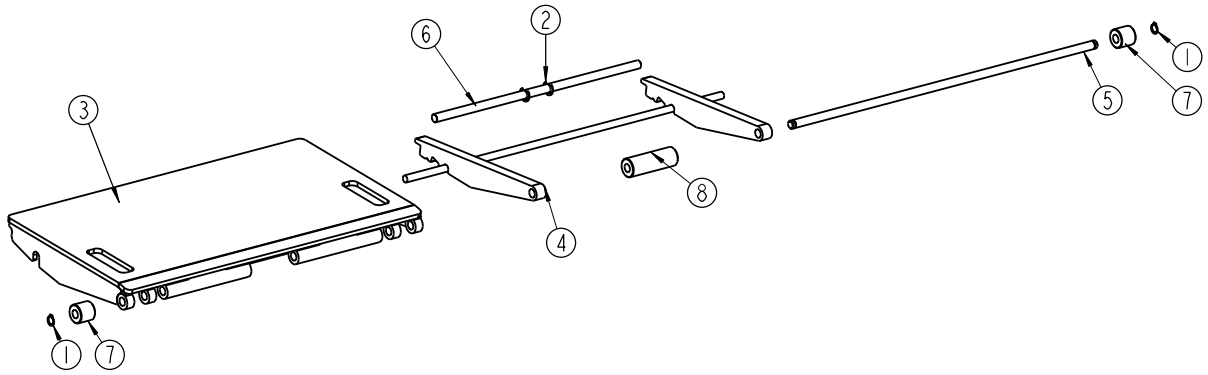

Detail for XX110003 ramp assembly

	PartNo.	Description	Qty
1	B60-14	Circlip Φ 14	2
2	B61-12	Circlip Φ 12	2
3	XX120007	Ramp weldment	1
4	XX120008	Ramp support weldment	1
5	XX130063	Ramp roller shaft	1
6	XX130064	Ramp roller shaft	1
7	XX130236	Roller	2
8	XX140009	Roller	1

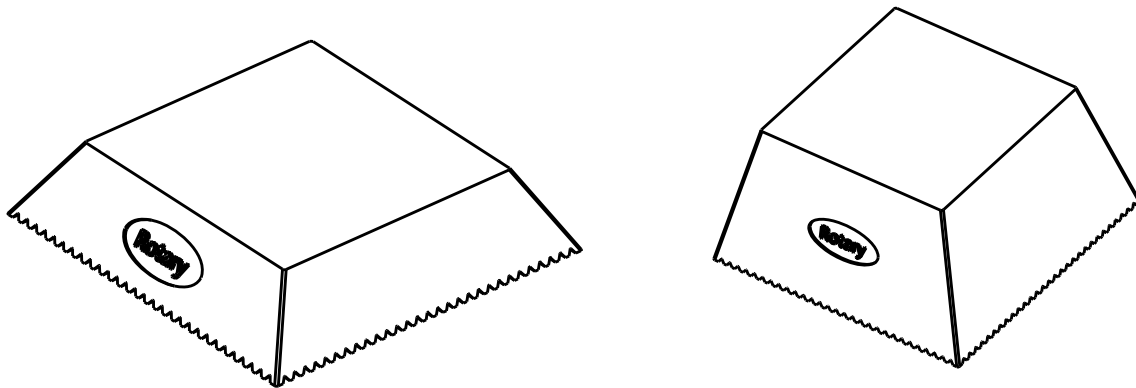

Detail for Rubber pad

	PartNo.	Description	Qty
1	XX140075	30mm rubber pad	4
2	XX140076	70mm rubber pad	4

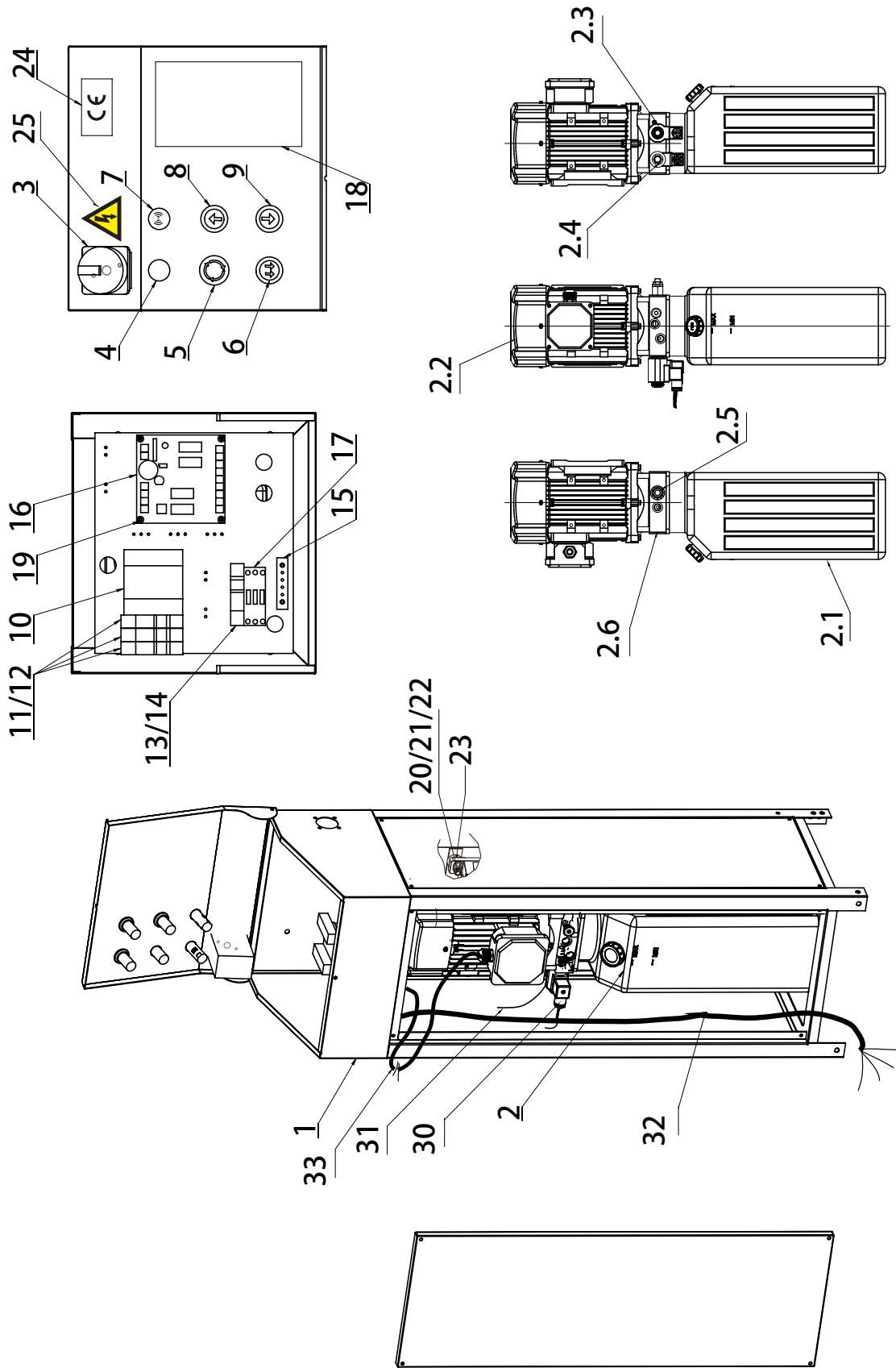

Detail for XX110021G (DS35D,3ph 50HZ 400V)

	PartNo.	Description	Qty
1	XX110016E	4 side open control cabinet (steel parts)	1
2	P3664	3Ph ,50HZ,400V per unit	1
2.1	YBZ-SLYX-10L-L-A	Tank	1
2.2	AM63-4ILC-3BA1	3kw motor	1
2.3	LSV-08-2NCSP-LM	Solenoid valve 24VDC	1
	LC3-10-C-2H	Coil	1
2.4	LSV2-08-2NCP-J	Solenoid valve 24VDC	1
	LC2-08-2H	Coil	1
2.5	LPSRV2-08-50	Relier Valve	1
2.6	LBZ-T131KK-1	Manifold	1
2.7	CBKA-F2.5F	Gear Pump	1
3	TO-2-1/EA/SVB (DQ-QJ-00034)	Main switch	1
4	AD16-22/W23(DQ-QJ-00028)	Light	1
5	CE4T-10R-01(DQ-QJ-00026)	Emergency stop switch	1
6	DS35-DQ-ZP3	Lower to ground button	1
7	AD16-22SM/R	Buzzer	1
8	DS35-DQ-ZP1	Up button	1
9	DS35-DQ-ZP2	Lower button	1
10	JBK5-230/380/400/AC18V	Transformer	1
11	LS501	Fuse Block	3
12	RT18-16	16A Fuse	3
13	DK10-TF	Fuse Block	1
14	50CF-010F	1A Fuse	1
15	PV-1030	Ground bar	1
16	DS35-DQ-PCB1A	PCB Board	1
17	XTCG012B00B0	Contactora	1
18	BQ-021E	Warning sticker	1
19	XG150085C	Pipe(PVC) stud	4
20	B30-8	Hex NutM8	8
21	B40-8	Lock Washer Φ8	8
22	B41-8	Flat washer Φ8	8
23	PV-2005	Damping bolt	4
24	BQ-002	CE sticker	1
25	C30-BQ9	Decal	1
26	FJ7352-3	Fiiting on P1/P2 Port	2
27	EPL8-03	Air fitting	1
28	EPY8	Y fitting	1
29		Black Air tube 8mm(in parts box)	20m
30	DS35D0-DQ4-2	EV1 Wire kit	1
31	DS35D0-DQ4-1	EV2 Wire kit	1
32	DS35EX-DQ4-4	Power cable 4*1.5 ²	1
33	DS35D0-DQ4-3	Motor cable 4*1.5 ²	1

* Note: Item 26/27/28/29 not show on the drawing.

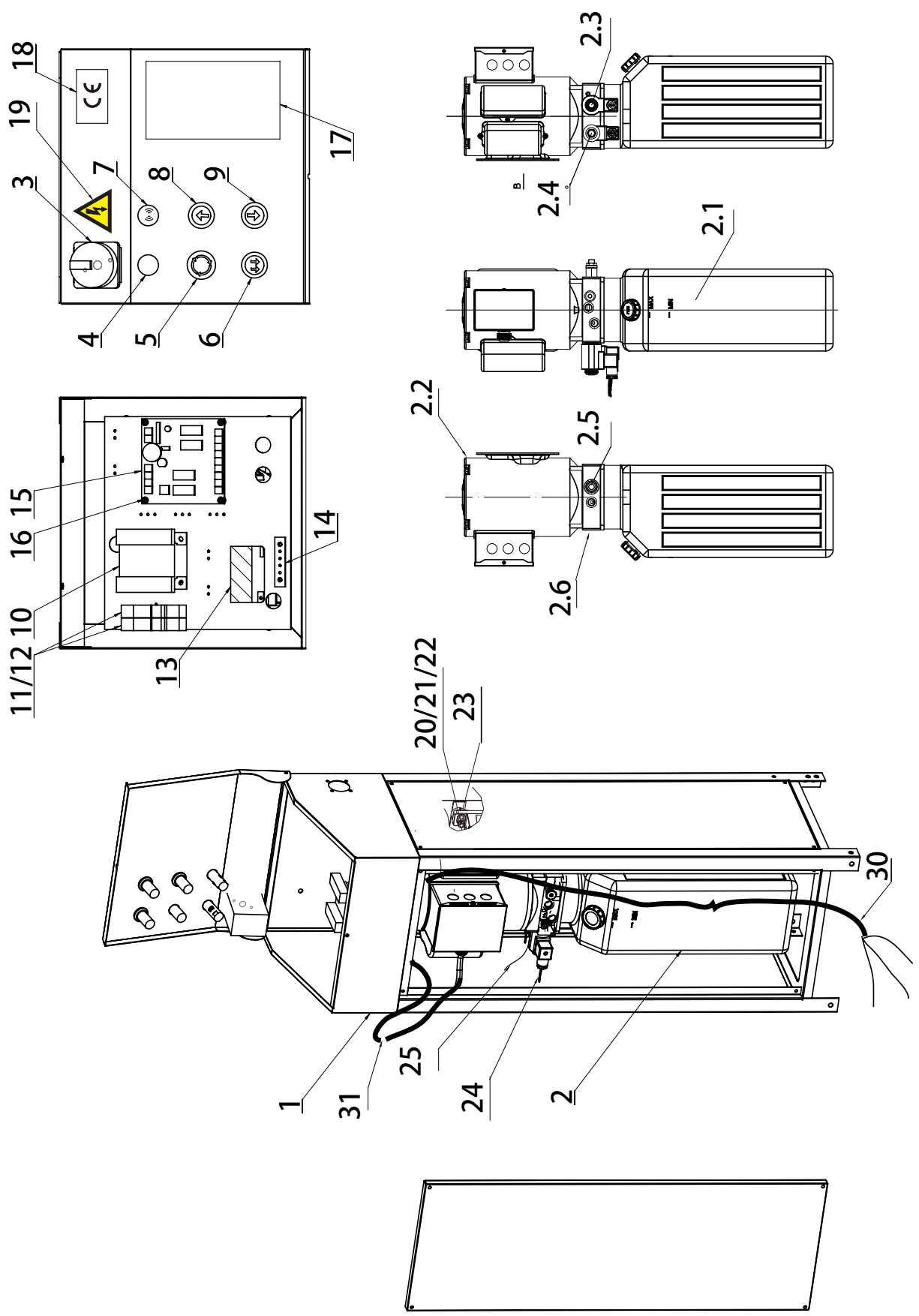

Detail for XX110019G (DS35N,1ph 50/60HZ 230V)			
	PartNo.	Description	Qty
1	XX110016E	4 side open control cabinet (steel parts)	1
2	P3669	3Ph ,50HZ,400V per unit	1
2.1	YBZ-SLYX-10L-L-A	Tank	1
2.2	AM11-21IAM-3BA2R	3kw motor	1
2.3	LSV-08-2NCSP-LM-2H	Solenoid valve 24VDC	1
	LC3-10-C-2H	Coil	1
2.4	LSV2-08-2NCP-J-2H	Solenoid valve 24VDC	1
	LC2-08-2H	Coil	1
2.5	LPSRV2-08-50	Relier Valve	1
2.6	LBZ-T131KK-1	Manifold	1
2.7	CBKA-F2.1F	Gear Pump	1
3	P1-25/EA/SVB(DQ-QJ-00003)	Main switch	1
4	AD16-22/W23(DQ-QJ-00028)	Light	1
5	CE4T-10R-01(DQ-QJ-00026)	Emergency stop switch	1
6	DS35-DQ-ZP3	Lower to ground button	1
7	AD16-22SM/R	Buzzer	1
8	DS35-DQ-ZP1	Up button	1
9	DS35-DQ-ZP2	Lower button	1
10	JBK5-230/380/400/AC18V	Transformer	1
11	LS501	Fuse Block	2
12	RT18-32	32A Fuse	2
13	RGF2BU024L	Relay	1
14	PV-1030	Ground bar	1
15	DS35-DQ-PCB1A	PCB Board	1
16	XG150085C	Pipe(PVC) stud	4
17	BQ-021E	Warning sticker	1
18	BQ-002	CE sticker	1
19	C30-BQ9	Decal	1
20	B30-8	Hex NutM8	8
21	B40-8	Lock Washer Φ8	8
22	B41-8	Flat washer Φ8	8
23	PV-2005	Damping bolt	4
24	DS35D0-DQ4-2	EV1 Wire kit	1
25	DS35D0-DQ4-1	EV2 Wire kit	1
26	FJ7352-3 & M130028Y	Fitting on P1/P2 Port	2
27	EPL8-03	Air fitting	1
28	EPY8	Y fitting	1
29		Black Air tube 8mm (in parts box)	20m
30	DS35EX-1PH-DQ4-4	Power cable 3*2.5 ²	1
31	DS35N0-DQ4-3	Motor cable 3*2.5 ²	1

* Note: Item 26/27/28/29 not show on the drawing.

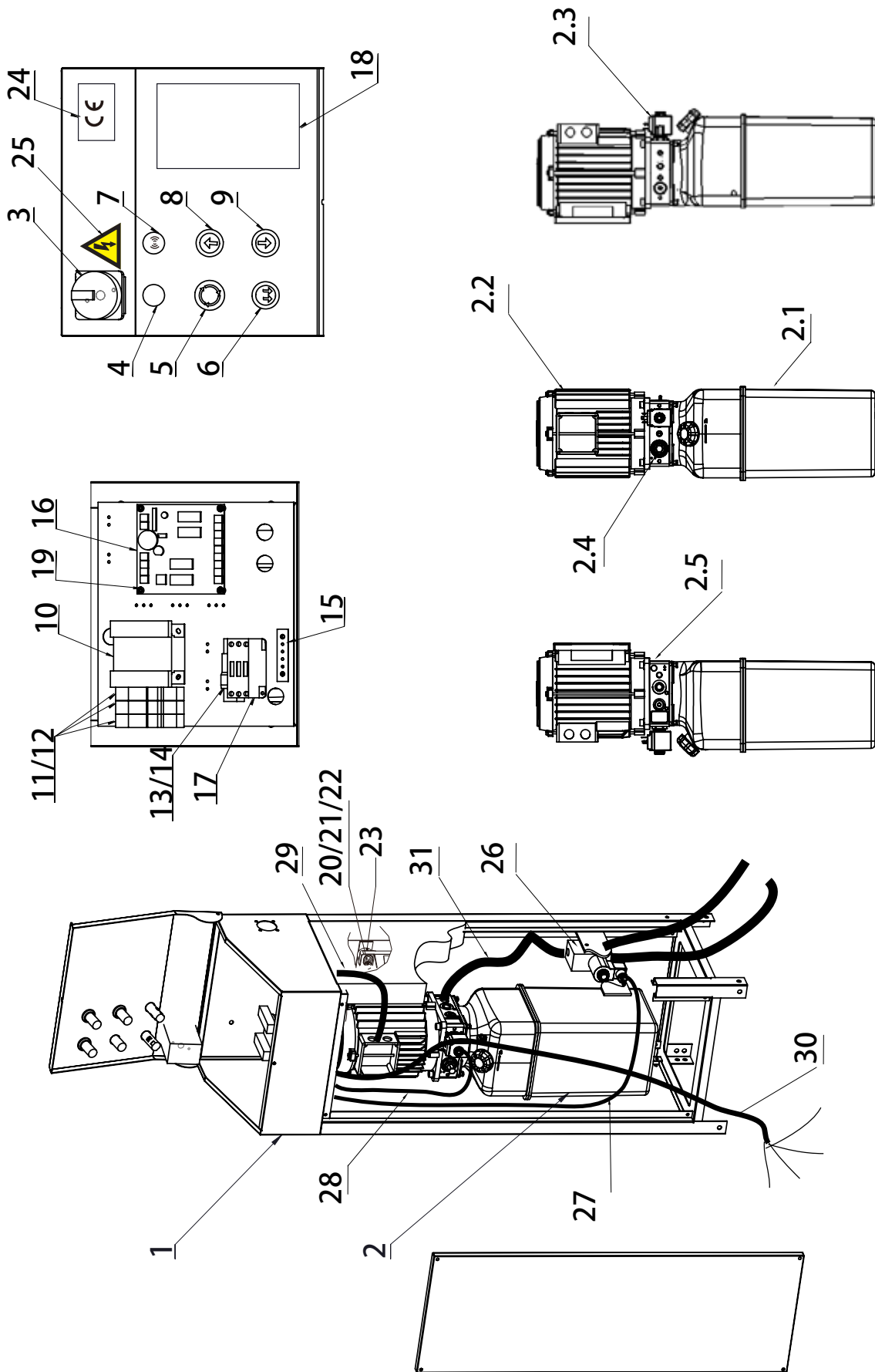

Detail for XX110030G (DS35E,3ph 50/60HZ 230V/400)			
	PartNo.	Description	Qty
1	XX110016E	4 side open control cabinet (steel parts)	1
2	P3660	3Ph ,50/60HZ,208/230/460V	1
2.1	P1535	Tank	1
2.2	FA7146	3kw motor	1
2.3	P3000-24	Lowering valve with 24VDC solenoid	1
2.4	P1000-19	Relier Valve	1
2.5	P3665-1	Manifold with pump	1
3	To-2-1/EA/SVB(DQ-QJ-00034)	Main switch	1
4	AD16-22/W23(DQ-QJ-00028)	Light	1
5	CE4T-10R-01(DQ-QJ-00026)	Emergency stop switch	1
6	DS35-DQ-ZP3	Lower to ground button	1
7	AD16-22SM/R	Buzzer	1
8	DS35-DQ-ZP1	Up button	1
9	DS35-DQ-ZP2	Lower button	1
10	JBK5-230/380/400/AC18V	Transformer	1
11	LS501	Fuse Block	3
12	RT18-25(220V) / RT18-16A(400V)	25A Fuse(220V) / 16A Fuse (400V)	3
13	DK10-TF	Fuse Block	1
14	50CF-010F	1 A Fuse (220V)	1
15	PV-1030	Ground bar	1
16	DS35-DQ-PCB1A	PCB Board	1
17	XTCG012B00B0	Contactora	1
18	BQ-021E	Warning sticker	1
19	XG150085C	Pipe(PVC) stud	4
20	B30-8	Hex NutM8	8
21	B40-8	Lock Washer Φ8	8
22	B41-8	Flat washer Φ8	8
23	PV-2005	Damping bolt	4
24	BQ-002	CE sticker	1
25	C30-BQ9	Decal	1
26	FKZJ-131A	Additional manifold with solenoid	1
27	DS35D0-DQ4-2	EV1 Wire kit	1
28	DS35D0-DQ4-1	EV2 Wire kit	1
29	DS35D0-DQ4-3	Motor cable 4*1.5 ²	1
30	DS35EX-DQ4-4	Power cable 4*1.5 ²	1
31	DSS35-9801-8	Hydraulic hose	1
32	FJ7352-3	Fitting on P1/P2 Port	2
33	EPL8-02	Air fitting(on the power unit tank)	1
34	EPY8	Y fitting	1
35		Black Air tube 8mm(in parts box)	20m

* Note: Item 31/32/33/34/35 not show on the drawing 61

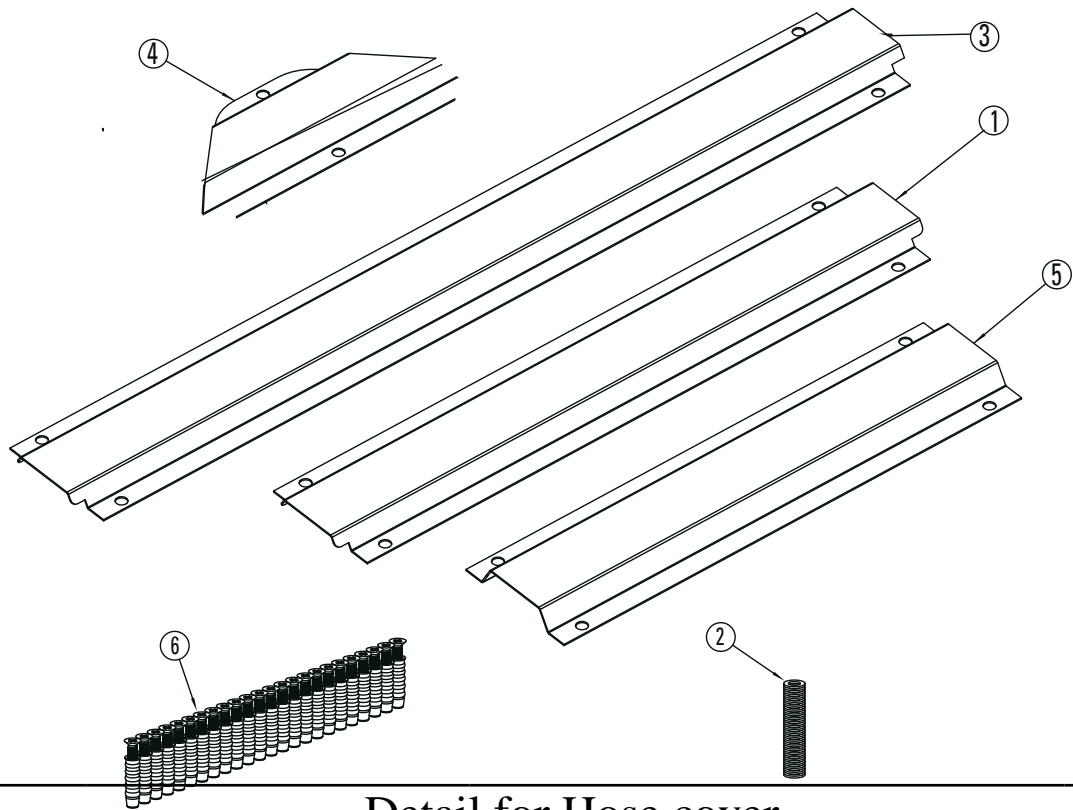

Detail for Hose cover

	PartNo.	Description	Qty
1	XX130091CN	Hose cover 827mm	4
2	B41-8	Flat washer 8	30
3	XX130111	Hose Cover 970mm	2
4	XX130141	Hose Cover 45°	2
5	XX130156	Hose Cover 550mm	3
6	B14B-6*40	Nylon anchors	30

Accessory 1

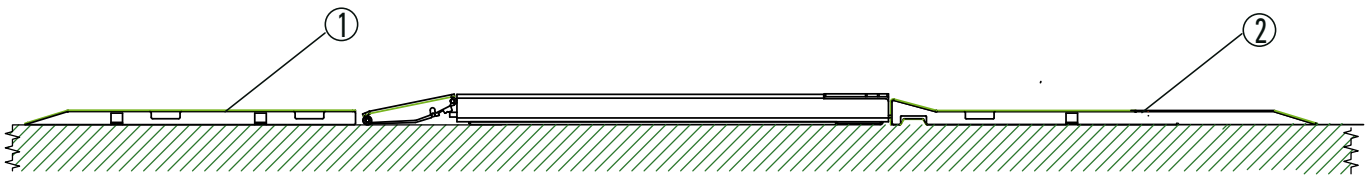

Detail for Sports ramp SPRMP-DS35EX

	PartNo.	Description	Qty
1	XX130270	Ramp weldment	2
2	XX130525	Ramp weldment	2
	B14B-6*40	Nylon anchors	20
	B25-8*20	Hex socket pan head screw M8*20	4
	B41-8	Flat washer 8	20

Accessory 2

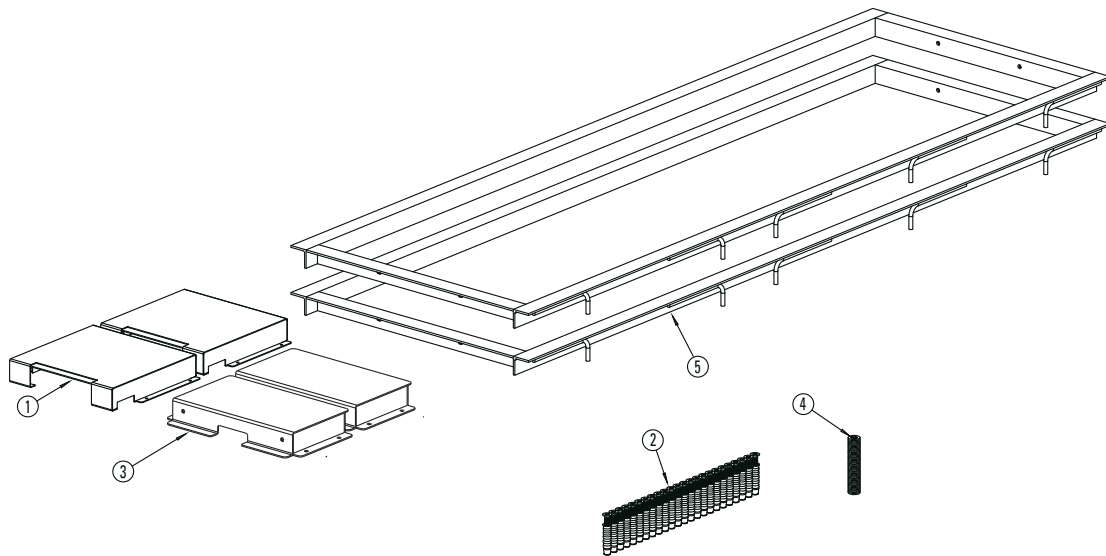

Detail for XX100025			
	PartNo.	Description	Qty
1	XX120060	Reccess Box welement	2
2	B14B-6*40	Nylon anchor	20
3	XX120030	Reccess Box weldment	2
4	B41-8	Flat washer 8	20
5	XX120055	Reccess weldment	2

Accessory 3

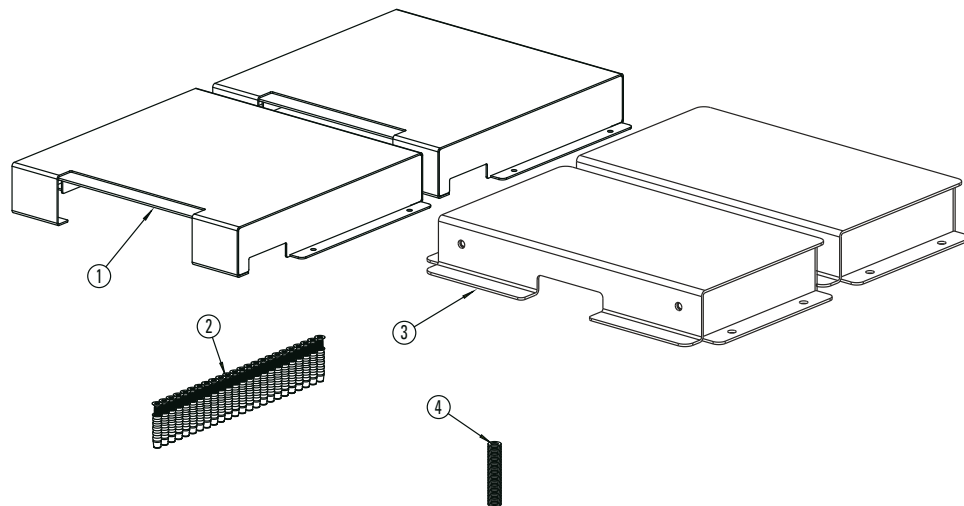

Detail for XX100024			
	PartNo.	Description	Qty
1	XX120060	Reccess Box welement	2
2	B14B-6*40	Nylon anchor	20
3	XX120030	Reccess Box weldment	2
4	B41-8	Flat washer 8	20

IV. Spare Parts List

1.

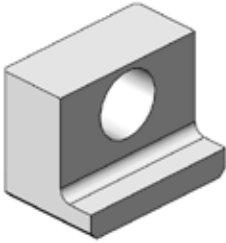

Part.No	Description	Qty	Dim
XX140007	Slider block(Lower)	4	

2.

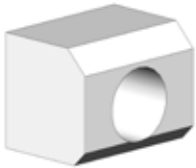

Part.No	Description	Qty	Dim
XX140008	Slider block(Upper)	4	

3.

Part.No	Description	Qty
XX140015Y	Bearing 25 dia*35 long	12
XX140014Y	Bearing 25dia*25 long	8
XX140017Y	Bearing 30 dia*50 long	8
XX140019Y	Bearing 25 dia*50 long	16
XX140067Y	Bearing 25dia*65long	2
XX140061	Bearing 20dia*25long	8

4.

Part.No	Description	Qty
XX100007	All Shafts kit for one platform	2

Part.No	Description	Qty
GLP35-D3	Shim kit for leveing	1

5.



Part.No	Description	Qty
XG130075	Proximity switch	3

6.

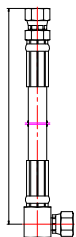

Part.No	Description	Qty
DSS35-9801-1L	Hose	1
DSS35-9801-2L	Hose	1
DSS35-9801-3L	Hose	1
DSS35-9801-4L	Hose	1

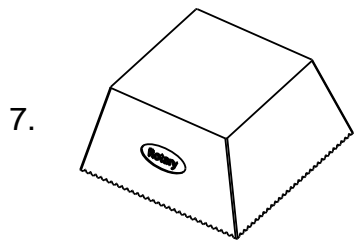

Part.No	Description	Qty	Dim
XX140075	Rubber pad	4	30mm
XX140076	Rubber pad	4	70mm



Part.No	Description	Qty	Dim
XX140009	Ramp roller	2	95mm L
XX130236	Ramp roller	4	30mm L



Part.No	Description	Qty	Dim
XX140010	Master Cylinder	2	
XX140011	Slave Cylinder	2	

Other hydraulic components

Part.No	Description	Qty	Remark
XX140010-15	Seal kit for cylinder XX140010	1	
XX140011-15	Seal kit for cylinder XX140011	1	

Protocol of installation

The lift, designation... (Address)... /

- After successful installation please filled completely this form, tick applicable points and sign the form.
- Copy the original and send them to the manufacturer within a week.
- Leave a copy in the test book.

The vehicle lift,

Type

Serial number:

was on

by the company
(Address)
.....

set up, checked for function and safety and put into operation.

The installation was carried out by the operator / Qualified person

the operator confirmed putting up the lift. All details of the operation. All information of the manual as well as the inspection book have been read and observed. These documents are available to the instructed operators at all time and are kept in an accessible place.

The expert (qualified person) confirms the correct installation of the lifting platform.

All information on the operating instructions and the inspection book have been read. The documents were handed over to the operator.

.....
Date Name of operator + company stamp Signature operator

.....
Date Name of qualified person Signature qualified person

.....
Customer service company

Completion certificate

The vehicle lift

Type

Machine -/serial number:

was on

by the company
(Address)
.....

installed, checked for function and safety and put into operation.

The following persons (operators) have been instructed in the handling of the vehicle lift by the trained installer of the manufacturer or contractor (expert) after the installation of the vehicle lift.

..... Date Name Signature operator
---------------	---------------	-----------------------------

..... Date Name Signature operator
---------------	---------------	-----------------------------

..... Date Name Signature operator
---------------	---------------	-----------------------------

..... Date Name Signature operator
---------------	---------------	-----------------------------

..... Date Name Signature operator
---------------	---------------	-----------------------------

..... Date Name Signature qualified person
---------------	---------------	-------------------------------------

.....
Customer service company + company stamp

ATTACHMENT

Scissor Lift

DS35EX

Maintenance schedule:
Notes for execution of the visual and
functional testing

Notes for execution of the visual and functional testing

In the scope of periodical inspections, the followings must be checked in particular:

1. Information on the lifting platform	Object to be checked
Nameplate Labeling Summary of the manual	Fastening Readability Completeness
2. Detailed operating instructions	Condition Readability
3. Warnings	Condition Noticeability
4. Protection against unauthorized use	Condition Function Mobility Safety key
5. Actuators	
Lifting, lowering Tilting, tipping Turning, pivoting Switching Opening and closing (of the loading tailgate) Driving Supports	Condition Function Mobility Clear assignment Permanent labeling of the direction of movement Protection against unintentional actuation Locking mechanism of the actuators with multiple controls
6. Emergency shutdown, Emergency drainage	Condition Function Mobility
7. Signalling devices, devices for communication	Condition Function Noticeability Reliability
8. Devices for the stable installation	
Spirit level Supports Spindles Bottom pan Elimination of the spring travel	Condition Function Mobility Wear Deformation Corrosion Cracks
9. Supporting structure	Cracks Deformation Corrosion Mobility of guides, pulleys, hinges, telescopes, Wear of guides, pulleys, hinges, fastening and securing of removable parts Effectiveness of locking mechanisms

10. Load suspension devices	
Protection against sliding Roll-off protection Holding device Protection of the hinged bracket	Condition Function
Safety fence	Condition Corrosion Fastening and securing of removable parts Effectiveness of locking mechanisms Mobility of movable parts
Ground	Surefootedness Deformation Corrosion Fastening and securing of removable parts
Parallel motion on operating platforms	Condition Function Wear Cracks Corrosion
Stowable operating platform	Condition and effectiveness of the locking mechanism
Stairs	Surefootedness Deformation Corrosion Damage Fastening and securing of removable parts Welded connections
11. Steel wire rope Cable connections	Wear Corrosion Wire breakages Wire break nests Pinch points Loosening of the outer layer Bird-caging
Sheaves and pulleys	Cracks Signs of wear Burr formation in the groove Correct aligning of the groove
Rope winding Clamping device Securing at rope bearings Protection against coming off of the rope	Condition Function
12. Steel link chains, chain linkings	Mobility Wear Cracks Securing of the studs, e.g. by rivet head, ring

Chain wheels Sprockets	Condition Function
Clamping device Securing of the chain guide	Condition Function
13. Spindles	Storage Deformation Contamination Wear of the threads Notches Striations Grooves, applications Efficiency of the covering
Main nut	Wear of the thread (play)
Compensation ring	Bearing Condition Notches Striations
14. Racks	Fastening Wear Contamination Joints of jointed racks
Pinions	Cracks Wear Contamination Fastening and play of the spindle
15. Hydraulics	Leakage Leak test Venting
Oil reservoir	Condition and readability of the display Control of the oil quantity Efficiency of the shut-off device in case of lack of oil
Lines Line connections	Fastening Damages Deformation Corrosion
Hoses Hose connections	Fastening Damage Age Brittleness Porosity
Cylinders	Fastening Cracks Pipe connections and hose connections Tightness of the sleeves
Pistons	Surface of the piston rod Striations Contamination

Filters	External condition
Pressure control valve	External condition Lead seal undamaged
16. Pneumatics	
Lines Line connections	Leakage Fastening Damage Deformation Corrosion
Hoses Hose connections	Fastening Damage Age Brittleness Porosity
Cylinders	Fastening, cracks, pipe connections and hose connections Tightness of the sleeves
Pistons	Surface of the piston rod, striations, contamination
Relief valve	External condition, lead seal undamaged
Gauge, pressure reducer	External condition and effectiveness
17. Driving mechanisms (without bogie)	Connections of parts of the driving mechanism shock-free starting
Brakes, self-locking gearbox, couplings	Wear, effectiveness
18. Driving carriage, bogie	
Service brakes, emergency brakes	Wear, effectiveness
Drawbar protection	Condition, effectiveness
Positive guide, guide rail Rail joints, end stops, cow-catcher Protection against derailling	Deformation, cracks, condition of the fastening
19. Points of access and points of loading	Surefootedness, deformation of handrails, damage Corrosion, securing of removable parts
20. Electrical equipment	
Lines	Damage, fastening, strain relief of external lines
Protective earth	Damage, fastening
21. Insulation on aerial work platforms, as far as the aerial work platform is intended for work on or near unprotected, live parts of electrical installations	
Insulation work platform/lifting equipment as well as lifting equipment/driving carriage	Contamination, damage, insulation resistance
22. Special safety devices	
Emergency limit switch, slack rope switch, rope break switch, chain fracture switch, control locks, switch-off strips, restart protection, anti-tipping device (for stowable work platforms), safety catch, completeness.	Effectiveness, fastening, condition Deformation, effectiveness of the switch elements, contamination, condition of pressure springs.

These notes do not claim to be complete, and they must be matched to the lifting platforms to be examined.

ATTACHMENT
Scissor Lift
Inspection log

Inspection log for Scissor Lift

Type:

Serial number:

Year of construction:

Operator:

Day of first commissioning:

Test Report

Of a periodic /special examination

The lifting platform underwent an examination regarding operational readiness on _____

The following/no*) faults found.

Test scope _____

Still pending _____

Partial tests

There are no*) reasons against continued operation, retesting is not*) required.

The technical expert/surveyor

(Place ,date)

(Signature)

Name and address

(in block letters) _____

Job title _____

Employed at _____

Operator or Representative

Deficiencies noted

(Place ,date)

(Signature)

Deficiencies fixed

(Place ,date)

(Signature)

Retesting

The lifting platform underwent retesting on _____

The deficiencies which were pointed out in the examination have not*) been fixed yet.

There are no*) reasons against continued operation, retesting is not*) required.

The technical expert/surveyor

(Place ,date)

(Signature)

Name

and

address

(in block letters) _____

Job title _____

Employed at _____

Test Report

Of a periodic /special examination

The lifting platform underwent an examination regarding operational readiness on _____

The following/no*) faults found.

Test scope _____

Still pending _____

Partial tests

There are no*) reasons against continued operation, retesting is not*) required.

The technical expert/surveyor

(Place ,date)

(Signature)

Name and address

(in block letters) _____

Job title _____

Employed at _____

Operator or Representative

Deficiencies noted

(Place ,date)

(Signature)

Deficiencies fixed

(Place ,date)

(Signature)

Retesting

The lifting platform underwent retesting on _____

The deficiencies which were pointed out in the examination have not*) been fixed yet.

There are no*) reasons against continued operation, retesting is not*) required.

The technical expert/surveyor

(Place ,date)

(Signature)

Name

and

address

(in block letters) _____

Job title _____

Employed at _____

Test Report

Of a periodic /special examination

The lifting platform underwent an examination regarding operational readiness on _____

The following/no*) faults found.

Test scope _____

Still pending _____

Partial tests

There are no*) reasons against continued operation, retesting is not*) required.

The technical expert/surveyor

_____ (Place ,date)

_____ (Signature)

Name and address

(in block letters) _____

Job title _____

Employed at _____

Operator or Representative

Deficiencies noted

_____ (Place ,date)

_____ (Signature)

Deficiencies fixed

_____ (Place ,date)

_____ (Signature)

Retesting

The lifting platform underwent retesting on _____

The deficiencies which were pointed out in the examination have not*) been fixed yet.

There are no*) reasons against continued operation, retesting is not*) required.

The technical expert/surveyor

_____ (Place ,date)

_____ (Signature)

Name

and

address

(in block letters) _____

Job title _____

Employed at _____

Test Report

Of a periodic /special examination

The lifting platform underwent an examination regarding operational readiness on _____

The following/no*) faults found.

Test scope _____

Still pending _____

Partial tests

There are no*) reasons against continued operation, retesting is not*) required.

The technical expert/surveyor

(Place ,date)

(Signature)

Name and address

(in block letters) _____

Job title _____

Employed at _____

Operator or Representative

Deficiencies noted

(Place ,date)

(Signature)

Deficiencies fixed

(Place ,date)

(Signature)

Retesting

The lifting platform underwent retesting on _____

The deficiencies which were pointed out in the examination have not*) been fixed yet.

There are no*) reasons against continued operation, retesting is not*) required.

The technical expert/surveyor

(Place ,date)

(Signature)

Name

and

address

(in block letters) _____

Job title _____

Employed at _____

Test Report

Of a periodic /special examination

The lifting platform underwent an examination regarding operational readiness on _____

The following/no*) faults found.

Test scope _____

Still pending _____

Partial tests

There are no*) reasons against continued operation, retesting is not*) required.

The technical expert/surveyor

(Place ,date)

(Signature)

Name and address

(in block letters) _____

Job title _____

Employed at _____

Operator or Representative

Deficiencies noted

(Place ,date)

(Signature)

Deficiencies fixed

(Place ,date)

(Signature)

Retesting

The lifting platform underwent retesting on _____

The deficiencies which were pointed out in the examination have not*) been fixed yet.

There are no*) reasons against continued operation, retesting is not*) required.

The technical expert/surveyor

(Place ,date)

(Signature)

Name

and

address

(in block letters) _____

Job title _____

Employed at _____

Test Report

Of a periodic /special examination

The lifting platform underwent an examination regarding operational readiness on _____

The following/no*) faults found.

Test scope _____

Still pending _____

Partial tests

There are no*) reasons against continued operation, retesting is not*) required.

The technical expert/surveyor

_____ (Place ,date)

_____ (Signature)

Name and address
(in block letters) _____

Job title _____

Employed at _____

Operator or Representative

Deficiencies noted

_____ (Place ,date)

_____ (Signature)

Deficiencies fixed

_____ (Place ,date)

_____ (Signature)

Retesting

The lifting platform underwent retesting on _____

The deficiencies which were pointed out in the examination have not*) been fixed yet.

There are no*) reasons against continued operation, retesting is not*) required.

The technical expert/surveyor

_____ (Place ,date)

_____ (Signature)

Name _____ and _____ address
(in block letters)

Job title _____

Employed at _____

Test Report

Of a periodic /special examination

The lifting platform underwent an examination regarding operational readiness on _____

The following/no*) faults found.

Test scope _____

Still pending _____

Partial tests

There are no*) reasons against continued operation, retesting is not*) required.

The technical expert/surveyor

(Place ,date)

(Signature)

Name and address

(in block letters) _____

Job title _____

Employed at _____

Operator or Representative

Deficiencies noted

(Place ,date)

(Signature)

Deficiencies fixed

(Place ,date)

(Signature)

Retesting

The lifting platform underwent retesting on _____

The deficiencies which were pointed out in the examination have not*) been fixed yet.

There are no*) reasons against continued operation, retesting is not*) required.

The technical expert/surveyor

(Place ,date)

(Signature)

Name

and

address

(in block letters) _____

Job title _____

Employed at _____

Test Report

Of a periodic /special examination

The lifting platform underwent an examination regarding operational readiness on _____

The following/no*) faults found.

Test scope _____

Still pending _____

Partial tests

There are no*) reasons against continued operation, retesting is not*) required.

The technical expert/surveyor

(Place ,date)

(Signature)

Name and address

(in block letters) _____

Job title _____

Employed at _____

Operator or Representative

Deficiencies noted

(Place ,date)

(Signature)

Deficiencies fixed

(Place ,date)

(Signature)

Retesting

The lifting platform underwent retesting on _____

The deficiencies which were pointed out in the examination have not*) been fixed yet.

There are no*) reasons against continued operation, retesting is not*) required.

The technical expert/surveyor

(Place ,date)

(Signature)

Name

and

address

(in block letters) _____

Job title _____

Employed at _____

Test Report

Of a periodic /special examination

The lifting platform underwent an examination regarding operational readiness on _____

The following/no*) faults found.

Test scope _____

Still pending _____

Partial tests

There are no*) reasons against continued operation, retesting is not*) required.

The technical expert/surveyor

(Place ,date)

(Signature)

Name and address

(in block letters) _____

Job title _____

Employed at _____

Operator or Representative

Deficiencies noted

(Place ,date)

(Signature)

Deficiencies fixed

(Place ,date)

(Signature)

Retesting

The lifting platform underwent retesting on _____

The deficiencies which were pointed out in the examination have not*) been fixed yet.

There are no*) reasons against continued operation, retesting is not*) required.

The technical expert/surveyor

(Place ,date)

(Signature)

Name

and

address

(in block letters) _____

Job title _____

Employed at _____

Test Report

Of a periodic /special examination

The lifting platform underwent an examination regarding operational readiness on _____

The following/no*) faults found.

Test scope _____

Still pending _____

Partial tests

There are no*) reasons against continued operation, retesting is not*) required.

The technical expert/surveyor

_____ (Place ,date)

_____ (Signature)

Name and address

(in block letters) _____

Job title _____

Employed at _____

Operator or Representative

Deficiencies noted

_____ (Place ,date)

_____ (Signature)

Deficiencies fixed

_____ (Place ,date)

_____ (Signature)

Retesting

The lifting platform underwent retesting on _____

The deficiencies which were pointed out in the examination have not*) been fixed yet.

There are no*) reasons against continued operation, retesting is not*) required.

The technical expert/surveyor

_____ (Place ,date)

_____ (Signature)

Name

and

address

(in block letters) _____

Job title _____

Employed at _____

Test Report

Of a periodic /special examination

The lifting platform underwent an examination regarding operational readiness on _____

The following/no*) faults found.

Test scope _____

Still pending _____

Partial tests

There are no*) reasons against continued operation, retesting is not*) required.

The technical expert/surveyor

_____ (Place ,date)

_____ (Signature)

Name and address

(in block letters) _____

Job title _____

Employed at _____

Operator or Representative

Deficiencies noted

_____ (Place ,date)

_____ (Signature)

Deficiencies fixed

_____ (Place ,date)

_____ (Signature)

Retesting

The lifting platform underwent retesting on _____

The deficiencies which were pointed out in the examination have not*) been fixed yet.

There are no*) reasons against continued operation, retesting is not*) required.

The technical expert/surveyor

_____ (Place ,date)

_____ (Signature)

Name

and

address

(in block letters) _____

Job title _____

Employed at _____

Test Report

Of a periodic /special examination

The lifting platform underwent an examination regarding operational readiness on _____

The following/no*) faults found.

Test scope _____

Still pending _____

Partial tests

There are no*) reasons against continued operation, retesting is not*) required.

The technical expert/surveyor

(Place ,date)

(Signature)

Name and address

(in block letters) _____

Job title _____

Employed at _____

Operator or Representative

Deficiencies noted

(Place ,date)

(Signature)

Deficiencies fixed

(Place ,date)

(Signature)

Retesting

The lifting platform underwent retesting on _____

The deficiencies which were pointed out in the examination have not*) been fixed yet.

There are no*) reasons against continued operation, retesting is not*) required.

The technical expert/surveyor

(Place ,date)

(Signature)

Name

and

address

(in block letters) _____

Job title _____

Employed at _____

Alterations and substantial

repairs

Type

Date/Name

BlitzRotary GmbH
Hüfinger Straße 55
D-78199 Bräunlingen



Tel +49.771.9233.0
Fax +49.771.9233.99
info@blitzrotary.com
www.blitzrotary.com

USA: +1.812.273.1622 (Headquarter)
Canada: +1.905.812.9920
United Kingdom: +44.178.747.7711
AustralAsia: +60.3.7660.0285

Latin America/Caribbean: +1.812.273.1622
Middle East/Northern Africa: +49.771.9233.0
Southern Africa: 1.812.273.1622
Brazil: +55.11.4534.1995

