

DOUBLE-SCISSOR LIFT

3.2 T ELECTRO-HYDRAULIC

The low-profile double scissor lift DS32 CAT-A was especially designed for the servicing area. The flexible loading platforms allow a wide loading range.

- + Full-metal scissors
- + Best corrosion protection as standard
- + Fully hydraulic system

The standard CE stop ensures a base protection without deflectors. This also allows an inground installation.

An emergency lowering is easily possible in the event of a power failure.

The design is distinguished by its utmost stability. The scissors are made of full metal.

Durability is also a top priority when it comes to rust protection - thanks to the cathaphoretic coating as standard with additional powder coating of the platform. The base frame is hot-dip galvanised.

With a platform length of up to 2160 mm, the DS32 CAT-A vehicles can accept up to VW T5/T6 with short wheelbase.

The superfluous double Master-Slave hydraulic system makes it possible to dispense with additional safety latches. Double the safety, thus preventing one-sided lifting or lowering.

To enable flexible accomodation of both small and large vehicles, the DS32 CAT-A has platform extensions which are foldable on both sides and easily locked.

All hydraulic cylinders are screwable. This increases the user friendliness.

The fully hydraulic system with built-in self-venting ensures a reliable operation even in dirty environments.

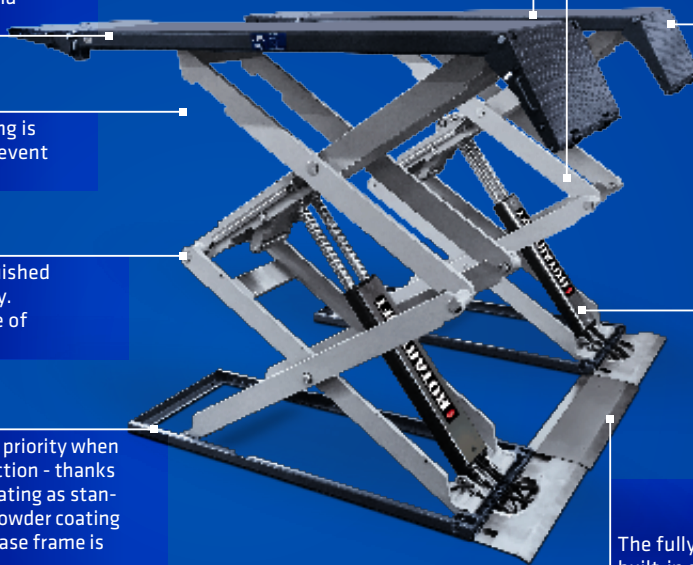

HIGHLIGHTS IN DETAIL

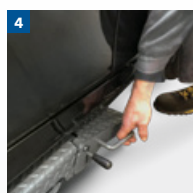

1 Problem-free operation of the extension with level installation.

2 A simple above-ground installation is possible as the lift provides a low clearance height.

3 Rubber pads included in the delivery scope provide reliable protection for the vehicle underbody.

4 The smart design allows the easiest operation of the extension, also with a vehicle above it.

DS32 CAT-A Above ground

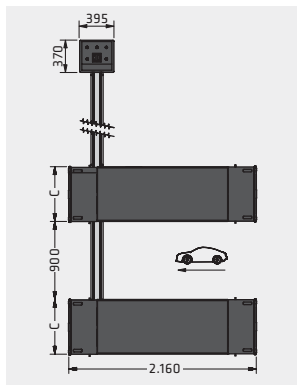
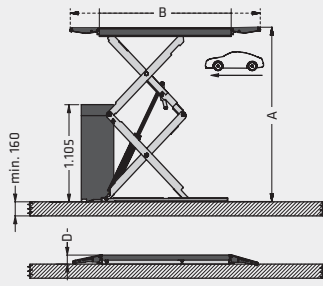

Rolling ramp, mounting frame

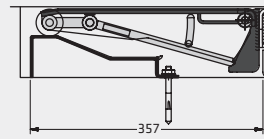

Neatly arranged and stable push buttons ensure safe operation of the lifting platform.

Documents or tablet computers have their place on the integrated storage area. Also perfectly suited as a writing support.

The pre-assembled control console has a quite hydraulic unit and thus contributes significantly to a low installation expenditure.

User friendliness is the top priority here too, the side parts on all 4 sides are removable, the electrical components are located underneath the foldable control and writing panel.

Positioning can occur on the left or the right, the hose length between lifting platform and console is 2 m.

Model	DS32 CAT-A
Rated load capacity	3.200 kg
A Stroke	1.945 mm
B Platform length	1.500–2.160 mm
C Platform width	630 mm
Lifting time loaded	40 s
Lowering time loaded	40 s
D Ascending height / Rest height	105 mm
Motor power	3 kW
Power supply voltage (electrical)	230 / 400 V, 50 Hz
Weight	885 kg
Article number	R013108

ACCESSORIES



Item No. X000014HG

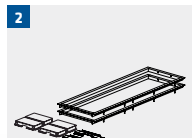

Item No. X100003HG



Item No. SRRMP-DS35HG



Item No. ROT-L983 (Similar to illustration)



Item No. XX140075



Item No. XX140076

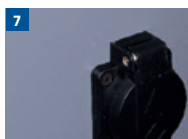

Item No. ROT-LKP230V

- 1 Installation kit for inground installation
- 2 Installation kit for inground installation, hot galvanized with angle steel frames
- 3 Additional ramps for sports cars, hot-dip galvanized and powder-coated, length 860 mm (1 set / 4 pieces)
- 4 Cross member for lifting of vehicles with pick-up points in the intermediate section of the platforms
- 5 Rotary rubber block pyramid stump with grip coatings, height 30 mm (1 set / 4 pieces)
- 6 Rotary rubber block pyramid stump with grip coatings, height 70 mm (1 set / 4 pieces)
- 7 Power Kit (230 V socket)