



Operating instructions

MONSUN Screw Compressors



| |
|-------------|
| Type |
|-------------|

| |
|----------------------|
| Serial number |
|----------------------|

| |
|-------------|
| Date |
|-------------|

EC Declaration of Conformity

according to EC directive 2006/42/EC on machinery (Annex II A)

| | |
|----------------------------|--|
| Hier Typenschild einkleben | |
| Typ | |
| Baujahr | |
| Seriennummer | |

Name and address of the manufacturer

BlitzRotary GmbH
Hüfinger Str.55
78199 Bräunlingen, Germany

This declaration relates exclusively to the machinery in the state in which it was placed on the market, and excludes components which are added and/or operations carried out subsequently by the final user. The declaration is no more valid, if the product is modified without agreement.

Herewith we declare, that the machinery described below

| | |
|-----------------------------|--|
| product denomination | Screw Compressor oilinjected |
| model / type | |
| MONSUN | MONSUN Pro; MONSUN Pro Navicon; MONSUN Pro Eco MONSUN Pro S; MONSUN Pro Eco S MONSUN; MONSUN Eco MONSUN S; MONSUN Eco S |

| | |
|----------------------------|-------|
| machinery- / serial number | |
| Year of manufacture | |

is complying with all essential requirements of the Machinery Directive 2006/42/EC. In addition the partly completed machinery is in conformity with the EC Directives 2014/30/EU relating to electromagnetic compatibility and 2014/35/EU relating to electrical equipment (Protection objectives have been met in accordance with Annex I No. 1.5.1 of the Machinery Directive 2006/42/EC)

In addition the partly completed machinery is in conformity with the EC Directives 2014/29/EU relating to simple pressure vessels directive.

Harmonised Standards used

| | |
|----------------------|--|
| EN 1012-1:2011-02 | Compressors and vacuum pumps - Safety requirements |
| EN 60204-1:2014-10 | Safety of machinery - Electrical equipment of machines |
| EN ISO 12100:2011-03 | Safety of machinery - Basic concepts |

Other technical standards and specifications used:

The person authorised to compile the relevant technical documentation:

BlitzRotary GmbH; Hüfinger Str. 55, 78199 Bräunlingen

Place : Bräunlingen
Date : 01.05.2019



Doris Wochner-McVey
Managing Director

Operating instructions

Component overview

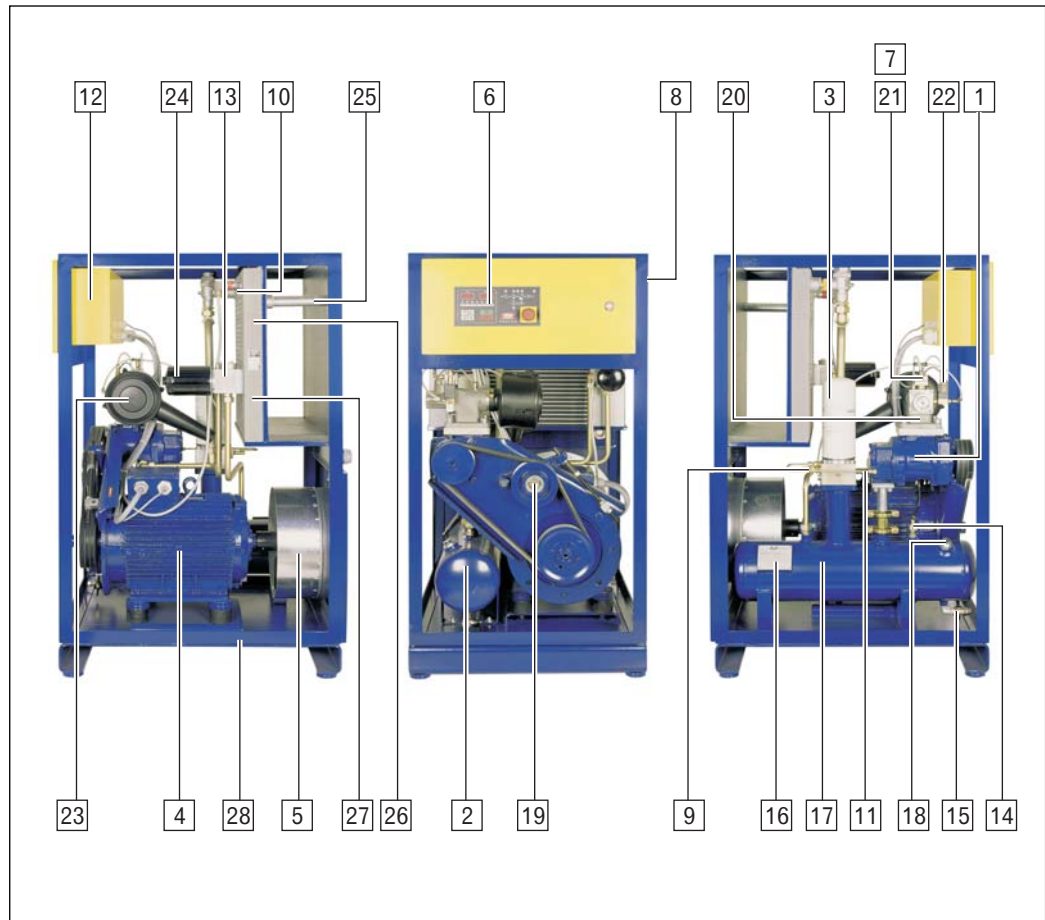

Fig. 1: Component overview

- | | |
|--|--|
| 1 Compressor | 15 Oil and condensation water drain valve |
| 2 Compressed air / oil reservoir | 16 Pressure reservoir name plate |
| 3 Oil high-precision separator cartridge | 17 Oil gauge |
| 4 Electric motor | 18 Oil filler neck |
| 5 Fan | 19 V-belt tensioning roller |
| 6 PROCON control | 20 Suction stop valve |
| 7 Proportional controller (optional) | 21 Control valve |
| 8 Name plate | 22 Relief valve |
| 9 Drain line | 23 Suction filter |
| 10 Pressure detector | 24 Oil filter |
| 11 Safety valve | 25 Compressed-air outlet with cut-off valve (optional) |
| 12 Switch box | 26 Compressed-air aftercooler |
| 13 Oil thermostat | 27 Oil cooler |
| 14 Temperature sensor | 28 Super sound proofing hood |

Operating instructions

PROCON control

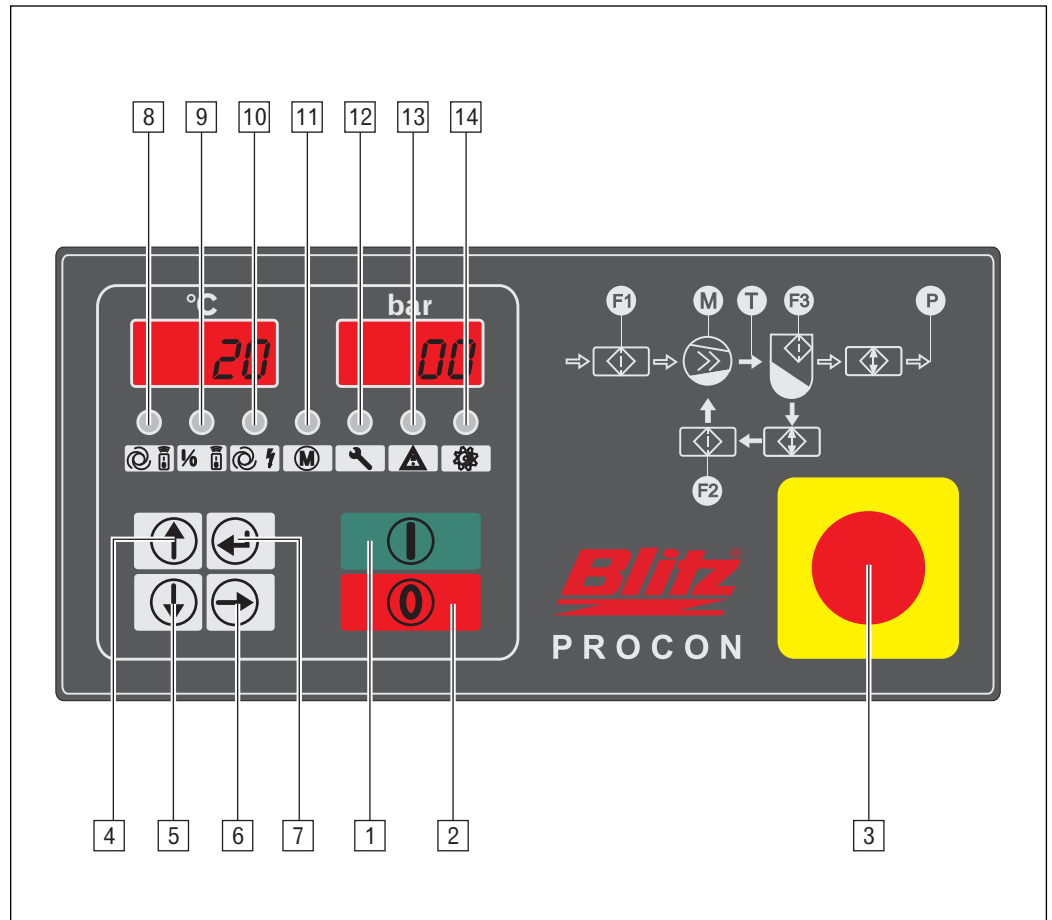

Fig. 2: Operating elements

- | | |
|----|--|
| 1 | Power switch |
| 2 | Circuit-breaking key |
| 3 | Emergency stop |
| 4 | In the menu: One line up |
| | Edit mode: Increase value |
| 5 | In the menu: One line down |
| | Edit mode: Selection of the menu |
| 6 | In the menu: Call up information |
| | Edit mode: Cancel value input |
| 7 | In the menu: Selection of the menu |
| | Edit mode: Apply value |
| 8 | Permanent yellow: Base load sequencer operating mode |
| 9 | Permanent yellow: Remote operation |
| 10 | Permanent yellow: Automatic restart |
| 11 | Permanent green: Motor is running |
| | Green flashing: Standby, motor can start automatically at any time |
| 12 | Blinking yellow: Maintenance |
| 13 | Blinking yellow: Warning |
| 14 | Red flashing: Type of malfunction |



Operating instructions

Table of contents

Table of contents

Technical annex

| | | |
|----------|--|-----------|
| | Component overview | |
| | PROCON control | |
| 1 | Fundamental safety instructions..... | 2 |
| 1.1 | Designated use..... | 2 |
| 1.2 | Fundamental measures..... | 2 |
| 1.3 | Description of symbols and notes..... | 2 |
| 2 | Transport and storage | 2 |
| 2.1 | Transport | 2 |
| 2.2 | Storage..... | 2 |
| 3 | Mounting | 3 |
| 3.1 | Mounting conditions..... | 3 |
| 3.2 | Compressed-air port | 4 |
| 3.3 | Electrical connection | 4 |
| 3.4 | Checking the rotating direction | 5 |
| 4 | Operation..... | 7 |
| 4.1 | Safety instructions | 7 |
| 4.2 | Switching the unit on | 7 |
| 4.3 | Start-up after an extended idle time..... | 7 |
| 4.4 | Weekly check | 7 |
| 4.5 | Switching the unit off | 7 |
| 4.6 | Remote control | 8 |
| 4.7 | Original BLITZ accessories..... | 8 |
| 5 | PROCON control | 9 |
| 5.1 | Operating elements | 9 |
| 5.2 | Display features..... | 9 |
| 5.3 | Input of parameters..... | 9 |
| 6 | Inspection and servicing | 13 |
| 6.1 | Safety instructions | 13 |
| 6.2 | Checking and topping up the oil level | 13 |
| 6.3 | Changing the oil | 14 |
| 6.4 | Changing oil filter..... | 14 |
| 6.5 | Draining the condensation water | 15 |
| 6.6 | Cleaning the oil cooler and the compressed-air aftercooler..... | 15 |
| 6.7 | Checking safety valve..... | 15 |
| 6.8 | Changing oil high-precision separator cartridge..... | 15 |
| 6.9 | Checking and changing the suction filter cartridge | 15 |
| 6.10 | Clean proportional controller nozzle.. | 16 |
| 6.11 | Cleaning drain restrictor | 16 |
| 6.12 | Checking and adjusting the V-belt | 16 |
| 6.13 | Notes on systems equipped with water cooling system..... | 17 |
| 6.14 | Tighten the screw connections..... | 17 |
| 6.15 | Checking electric terminals..... | 17 |
| 6.16 | Relubricating / replacing motor mounting | 17 |
| 7 | Maintenance schedule..... | 18 |
| 8 | Trouble shooting | 20 |
| 8.1 | Malfunction, compressor generally.... | 20 |
| 8.2 | Malfunction, PROCON control..... | 24 |
| 8.3 | Warnings, PROCON control | 25 |

Operating instructions

Fundamental safety instructions

1 Fundamental safety instructions

1.1 Designated use

The compressor system is intended exclusively for the generation of compressed air. Any other use shall be considered an undesignated use.

1.2 Fundamental measures

- Never point compressed air at persons.
- Observe these operating instructions.
- Keep these operating instructions available at the location of use at all times.
- Please observe the regular maintenance intervals (refer to chapter 7 "Maintenance schedule").
- Use original BLITZ parts and approved operating material only.
- Do not use compressed air for breathing without corresponding treatment.
- Do not modify the system.
- Use mounting parts and devices downstream from the compressor which have been designed for the maximum operating overpressure of the compressor.
- In your capacity as proprietor, please ensure that all safety regulations are observed by the operating staff.
- Do not use the compressor as a climbing aid.

1.3 Description of symbols and notes



Danger
Mortal danger and risk of injury.



Caution
Damage to property.



Information and tips.

2 Transport and storage

2.1 Transport



Danger
Mortal danger caused by incorrect transport.

- Do not hold the compressor at its cladding elements as you lift it.
- Only use suitable lifting gear with the corresponding weight-bearing capacity (for data on weight, please refer to chapter "Technical annex").
- Fasten and secure the system with belts at the corresponding points.
- Secure swivelling and loose parts.
- Transport the compressor by means of crane hooks, fork-lift truck and elevating truck only.
- Never remain under suspended loads.
- Depressurise the compressor prior to any transport.

2.2 Storage

Store the compressor in a dry location protected against weather influence. Ambient temperature: -10°C to +50°C.

Please order the BLITZ conservation instructions in case of storage of over six months.



For information on recommissioning after an extended idle time, please refer to chapter 4.3.

Operating instructions

Mounting

3 Mounting

3.1 Mounting conditions

- Check the compressor for damage during transport.

Ambient conditions



Danger

Mortal danger and explosion hazard when caustic, inflammable or poisonous gases are drawn in.

- Do not operate the compressor in explosive surroundings or in the vicinity of open flames and flying sparks.



Caution

Wrong mounting will cause damage to the compressor.

- Ensure sufficient ventilation of the compressor room.
- Do not operate the compressor in the open.
- Systems with a capacity exceeding 40 kW must be installed in such a way that no combustible objects or materials are in the immediate proximity.
- Systems with a capacity exceeding 100 kW should be installed in a separate room.

The space between the compressor and the wall has to be at least 60 cm (cf. Fig. 3: Location). The compressor has to be easily accessible from all sides. The ambient temperature has to be between 3°C and 40°C.

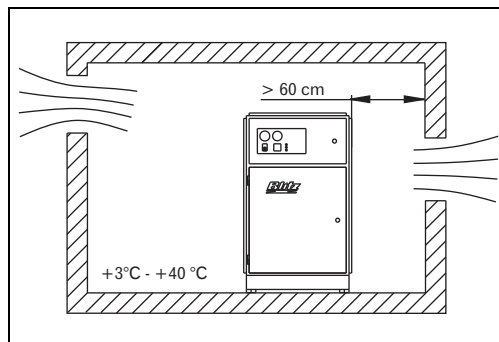

Fig. 3: Location

Cooling and exhaust air



Danger

Mortal danger and explosion hazard during suction.

- Ensure that the compressor takes in only clean air which is free from noxious constituents. Noxious substances are liable to accumulate in the lubricating oil of the compressor. They may cause explosions in the system and heavy damages.
- Do not allow objects or pieces of clothing of persons going past to be sucked in by the intake air flow.

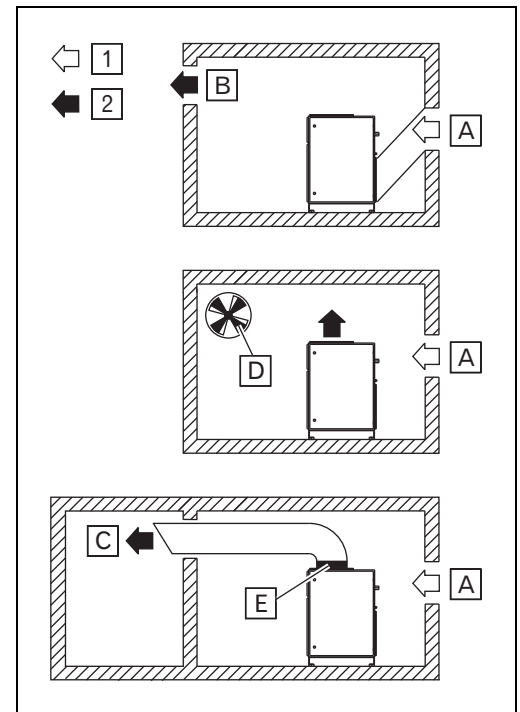

Fig. 4: Room ventilation

- 1 Intake air
- 2 Exhaust air
- A Air inlet
- B Air outlet
- C Ventilation duct
- D Exhaust fan
- E Elastic connecting piece

Operating instructions

Mounting

The overall length of all air intake and exhaust ducts must not exceed 4m; one baffle is permissible. In case of conduits exceeding this length or in case of several baffles, a booster fan must be installed. In this case, please contact your technical adviser.

For further information on the required ventilation cross sections, please refer to the Technical Annex.

Ground

- Place the compressor on a horizontal and plane surface.

The ground has to have a suitable load-bearing capacity. BLITZ offers special solutions for inclined surfaces.

In order to reduce vibrations, BLITZ recommends rubber-metal connections.

3.2 Compressed-air port

The connection to the compressed-air ductwork system may be carried out only by trained experts or by staff members of BLITZ Company.



Danger

Danger of injury by pressure in the pipes.

- Vent the pipes to which the compressor is connected.



Use a flexible hose to connect the compressor to the supply network. Thus, stress cracks and sound bridges are prevented.

- Compressed-air lines, filters, after coolers and vessels must at their lowest spots be equipped with an outlet for the condensation water accumulated. These outlets must allow to observe the draining condensation water. Condensation water may contain oil! In draining the condensation water, all applicable regulations on the disposal of waste water must be complied with.
- Remove all securing devices before you start to install the conduits.
- Use only suitable connecting lines and couplings which are designed for the intended working pressure. Do not use any defect component.
- Supply lines must not be subjected to stress or tension.

Observe the technical data for the connection of compressed air (cf. chapter "Technical annex").

3.3 Electrical connection

The connection to the electrical power system may be carried out only by adequately trained expert.



Danger

Mortal danger caused by electric voltage but also by rotating wheels, V-belts, and fan blades.

- Test runs are permissible only if all parts of the casing are closed (exception: check of the rotating direction).

Compressor systems have to be fitted with a power switch or a plug connection to interrupt the power supply. Compressor systems with a motor capacity of more than 3 kW or 16 Amps have to be fitted with a lockable power switch and upstream fuses.



In this respect, please refer to the circuit diagram in the chapter titled "Technical annex" or in the switch cabinet as well as to the following connection conditions.



Check and retighten where appropriate all electric terminals before first commissioning.

Operating instructions

Mounting

3.4 Checking the rotating direction

**Caution**

Fire hazard and damage to compressor in case of wrong polarisation of the motor (5 revolutions maximum in the wrong direction of rotation!).

- Carry out the check of the rotating direction as described below:

-
- Open side cladding of the compressor.
 - Please refer to chapter 4.2 titled "Switching the unit on".
 - Press the power switch, and immediately after this the emergency stop (see fig. 2: Operating elements). The correct rotating direction of the fan has been marked by an arrow on the fan cover.
 - Change the poles of the electric connection of the motor in case of a wrong rotating direction.

Operating instructions

Mounting

Electrical connection conditions

The connection to the electrical power system may be carried out only by adequately trained expert.



Caution

Overvoltages and undervoltages must not exceed the 10% mark.



This unit is intended for operation on a power supply network with a maximum system impedance Z_{max} at the interconnection point (house service line), which is listed in the table below in dependence of the performance. The user shall have to ensure that the unit is operated only on a power supply network which meets these requirements. If and when necessary, the local power supply company can provide information on the system impedance.

| 400V-50Hz 3 ph | | | | 230V-50Hz 1 ph | | | |
|-------------------|---------------------|----------------------------------|------------------------------|-------------------|---------------------|----------------------------------|------------------------------|
| Motor performance | Motor rated current | Protection – star-delta starting | Protection – direct starting | Motor performance | Motor rated current | Protection – star-delta starting | Protection – direct starting |
| kW | A | A | A | kW | A | A | A |
| 1.1 | 2.6 | | 6 | 1.1 | 2.6 | | 6 |
| 1.5 | 3.5/4.1 | | 10 | 1.5 | 3.5/4.1 | | 10 |
| 2.2 | 5.0/6.0 | | 16 | 2.2 | 5.0/6.0 | | 16 |
| 3.0 | 6.6/8.1 | | 16 | 3.0 | 6.6/8.1 | | 16 |
| 4.0 | 8.5 | 16 | 20 | 4.0 | 8.5 | 16 | 20 |
| 5.5 | 11.5 | 20 | | 5.5 | 11.5 | 20 | |
| 7.5 | 15.5 | 25 | | 7.5 | 15.5 | 25 | |
| 11.0 | 22.5 | 35 | | 11.0 | 22.5 | 35 | |
| 15.0 | 30.0 | 50 | | 15.0 | 30.0 | 50 | |
| 18.5 | 36.0 | 50 | | 18.5 | 36.0 | 50 | |
| 22.0 | 43.0 | 63 | | 22.0 | 43.0 | 63 | |
| 30.0 | 58.0 | 80 | | 30.0 | 58.0 | 80 | |
| 37.0 | 68 | 80 | | 37.0 | 68 | 80 | |
| 45.0 | 81 | 100 | | 45.0 | 81 | 100 | |
| 55.0 | 99 | 125 | | 55.0 | 99 | 125 | |
| 75.0 | 134 | 160 | | 75.0 | 134 | 160 | |

Tab. 1: Characteristic value for the electrical connection

The supply line cross sections provided are recommended values for a maximum 50m line length at 30°C. For fuse protection, use “slow-to-blow” or “gL” fuses.

- 220/240 V systems require a three-core 1P/N/PE cable.
- 380/400 V systems require a four-core 3P/PE cable for direct start.
- 380/400 V systems require for star-delta starting a five-core supply line 3P/N/PE.

Operating instructions

Operation

4 Operation

4.1 Safety instructions

**Danger**

Mortal danger caused by sudden start-up of the system.

- Systems which are in the standby operating mode are liable to start automatically at any time.
- All parts installed behind the check valve (e. g. aftercooler, pressure switch) are not released automatically from pressure.
- Not all transmission lines are de-energised when the system is switched off!
- Before commissioning, ensure that no person can be injured by the starting compressor.
- Never point compressed air at persons.
- Do not use compressed air for breathing without corresponding treatment.
- Use mounting parts and devices downstream from the compressor which have been designed for the maximum operating pressure of the compressor.
- Do not reach into the rotating wheels when the compressor is operational.
- Touch the compressor system at the on and off switch only during and shortly after operation. Hot surface can cause severe injuries.
- Switch the compressor off immediately in case of faults.
- Keep combustible materials away from the compressor system.
- Operate the compressor only with suction filter and if all parts of the casing are closed.
- Operate the compressor only at the permissible operating pressure of the pressure reservoir.
- Tighten the screw connections of the pressure pipes.
- Wear tight-fitting work cloths when handling the compressor.
- Wear goggles and ear muffs when working with compressed air.
- Wear a hair net to protect long hair and remove any loose jewellery.
- Check the cables for damage in regular intervals.
- Keep domestic animals and children away from the compressor system.
- Switch the compressor off when not needed.

4.2 Switching the unit on

- Check oil level through oil gauge and top up the oil if and when necessary (refer to chapter 6.2 "Checking and topping up the oil level").
- Switch on the power switch.
- Press power switch (see fig. 2: operating elements).
- Signal lamp indicates readiness for operation.
- Compressor starts and after approx. 10sec. starts load operation.
- Open ball valve.

In case of faults, please refer to chapter 8 titled "Trouble shooting" for more help.

4.3 Start-up after an extended idle time.

During an extended idle time, the complete oil content flows into the compressed air / oil reservoir. If this has happened, the screw compressor is not any more lubricated.

- Dismount intake regulator.
- Fill approx. 1 litre compressor oil into the air intake fitting.
- Mount intake regulator.



Do not mix different types of oil. In choosing the oil you want to use, refer to the corresponding BLITZ specifications (refer to chapter 6.2 "Checking and topping up the oil level").

4.4 Weekly check

- Check oil level of the compressor (refer to chapter 6.2 "Checking and topping up the oil level").

4.5 Switching the unit off

- Press circuit-breaking key "0" (see fig. 2: operating elements).
- Switch off power switch.

Operating instructions

Operation

4.6 Remote control

All systems which are equipped with remote control must bear a clearly visible label reading as follows: "Warning! This system is remotely controlled and is liable to start at any time." In addition, persons operating remotely controlled systems must ensure that the system is not started during maintenance or repair work. For this, a corresponding information sign must be affixed to the remote control unit.

- Open ball valve.
- Press power switch (see fig. 2: operating elements).
- Signal lamp indicates readiness for operation.
- System is now ready to be operated via remote control.

4.7 Original BLITZ accessories

BLITZ offers you the following accessories: For more information, please refer to the BLITZ price list or directly to BlitzRotary GmbH.

Compressed-air filter

To clean the compressed air for special applications.

Refrigeration or adsorption dryer

To prevent faults of the compressed air duct-work system, compressed-air tools, instruments and controls caused by humid air.

Automatic condensation water drain

To spare you the daily draining of condensation water.

Oil and water separator

Is fitted downstream of the condensation water drain. The separated water can be removed directly into the sewer system.

Rubber-metal connection

To reduce vibrations.

Top sound insulation

To reduce noise emissions.

Base load sequencer

Intelligent higher-order control system to control several compressors depending on the actual compressed air consumption.

Speed regulator

Adapts speed and thus also energy consumption of the screw compressor to the actual compressed air consumption.

Water-cooling system

For application conditions under which the standard fan cooling is not sufficient.

Heat exchanger

Free of charge energy derived from heat produced by the compressor during operation which is then available to other consumers.



For more information on these and other pneumatic accessories, please refer to BLITZ. Our address is on the last page of these operating instructions.

Operating instructions

PROCON control

5 PROCON control

5.1 Operating elements

See fig. 2 PROCON control

5.2 Display features

Basic display

During normal operation, the display indicates both network pressure and final compression temperature as three-digit figures.

In the event of pressure or temperature measurement failure, the corresponding field shows "- -". The load operation of the system is indicated through a dot following the network pressure value.

In the event of malfunction reports or warnings occurring, these will alternate with the analogue quantities in the pressure display every three seconds. Malfunction reports in the display start with an "E" followed by a two-digit malfunction code (refer to chapter 8.2 "Malfunction, PROCON control" and chapter 8.3 "Warnings, PROCON control") whereas warnings start with an "A". In addition, in case of malfunction a malfunction LED will light up; in case of a warning a warning LED will light up.

Information menu

- To call up the first line of the information menu, keep key 6 (→) pressed for one second.
- The keys 4 and 5 (↑/↓) allow you to navigate within the menu structure.
- Press key 6 (→) to exit the menu; alternatively, the menu is also exited if no key has been pressed for 3 minutes.

- Line 1:
System pressure indicator. The system pressure is displayed in place of the network pressure. "P2" will appear on the left side of the display. This line will appear only in case the system pressure input is activated in the option menu. In case an incorrect system pressure value has been obtained, the display will show "- -".
- Line 2:
Hours of operation. Hours of operation are indicated as five-digit figures. "R." will appear on the left side of the display (e. g. "R.23 456" for 23456h).

- Line 3:
Load operation hours. Load operation hours are indicated as five-digit figures. "L." will appear on the left side of the display (e. g. "L.12 345" for 12345h).
- Line 4:
Air filter operating life. In the display "F1" alternates with the corresponding operating life value. In addition, the maintenance LED flashes.
- Line 5:
Oil filter operating life. In the display "F2" alternates with the corresponding operating life value. In addition, the maintenance LED flashes.
- Line 6:
Oil separator operating life. In the display "F3" alternates with the corresponding operating life value. In addition, the maintenance LED flashes.
- Line 7:
Oil operating life. In the display "OIL" alternates with the corresponding operating life value. In addition, the maintenance LED flashes.
- Line 8:
V-belt operating life. In the display "BE." alternates with the corresponding operating life value. This line will appear only in case the V-belt is activated in the option menu. In addition, the maintenance LED flashes.
- Line 9:
Software version, e. g. "PRO 1.00" for Version 1.00.

5.3 Input of parameters

Selection menu

- In order to enter parameters, keep key 7 (↵) pressed for three seconds. "COD.000" will appear in the display.
- Enter the code for the desired menu using the keys 4 and 5 (↑/↓).
- Confirm by pressing key 7 (↵), and the first parameter of the selected menu is displayed.
- In case an invalid code has been entered, or key 6 (→) has been pressed, the routine returns to the initial display.

Selection of parameters within a menu

- The keys 4 and 5 (↑/↓) allow you to navigate within the menu structure in the display modus.

Operating instructions

PROCON control

- Press key 6 (→) to exit the menu; alternatively, the menu is also exited if no key has been pressed for 5 minutes.

Editing parameters within a menu

- Press key 7 (↵) to modify parameters. You are then in the edit mode. This is indicated by the corresponding parameter value flashing.
- The keys 4 and 5 (↑/↓) allow you now to modify the value.
- Press key 6 (→) to return to the display mode, and retain the previous value.
- Press key 7 (↵) to save the current value and to enter the next value that can be modified.



In the event values have been modified within one menu, storage of the new values is signalled through a horizontal bar (for one second).

Pressure control menu (Code 010)

| Name | Message | Setting range | Factory setting |
|--------------------------|---------|--|-----------------|
| Minimum network pressure | A1. ### | Between 5.0 bar and maximum network pressure | 8.5 bar |
| Maximum network pressure | A2. ### | Between minimum network pressure and system pressure | 10.0 bar |

Tab. 2: Pressure control menu

Maintenance menu (Code 020)

| Name | Message | Setting range | Factory setting |
|---------------------------|---------|---------------|-----------------|
| Air filter operating life | C1. ### | 0-9999h | 2000 |
| Oil filter operating life | C2. ### | 0-9999h | 500* |

| | | | |
|------------------------------|---------|---------------|--------------|
| Oil separator operating life | C3. ### | 0-9999h | 2000 |
| Oil operating life | C4. ### | 0-9999h | 500* |
| V-belt operating life | C5. ### | 0-9999h | 0 (inactive) |
| Shutdown maintenance | C6. # | 0=No 1=Yes | No |

Tab. 3: Maintenance menu

- * only first maintenance interval; the remaining intervals are 2000h

The maintenance intervals can be specified between 0-9999h while the input „0“ means that this interval should not be edited. In this place only the target values of the maintenance intervals are indicated; please infer the actual count from the information provided in the initial display (refer to initial display in chapter 5.2 “Display features”).

After a maintenance interval has been modified, the corresponding count is reset while the new set value is being applied. Thus the respective interval can start again, for instance after maintenance work has been completed.

Use the “C6” parameter to decide whether the compressor should be shut down after the maintenance interval has been exceeded by more than 100h. After the compressor has been shut down this way, the operator can acknowledge this error message and start the compressor for another 100h.



Operating instructions PROCON control

Operating parameter menu (Code 030)

| Name | Message | Setting range | Factory setting |
|---|---------|---------------|-----------------|
| Base load sequencer operating mode | B1. # | 0=No 1=Yes | No |
| Continuous operation | B2. # | 0=No 1=Yes | No |
| Remote operation | B3. # | 0=No 1=Yes | No |
| Re-starts automatically after power failure | B4. # | 0=No 1=Yes | No |
| Power failure time | B5. ## | 0-60s | 1s |
| Re-start delay | B6. ## | 0-60s | 0s |

Tab. 4: Operating parameter menu

The pressure control is effected via an external contact during programmed operation of the base load sequencer.

In case the remote control is activated the start-up is effected via an external contact. The control system reacts only to the positive signal edge for start-up of the device. If there is no input signal this means that the compressor is switched off. In this case you cannot use the keyboard to switch on or off the device.

The "continuous operation" parameter allows to operate the compressor in the no-load operation mode and thus to prevent it from being switched off.

You can specify two periods if the automatic restart after voltage breakdown has been activated. The power failure time specifies the maximum allowable period of voltage breakdown after which it is permitted to restart the device. If this value is set to "0", the device can be restarted at any time. The re-start delay allows to prevent the compressor from re-starting immediately after voltage recovery. This may be necessary to prevent several compressors connected to the mains network from starting simultaneously.

Operating instructions

PROCON control

Menu structure, customer menu

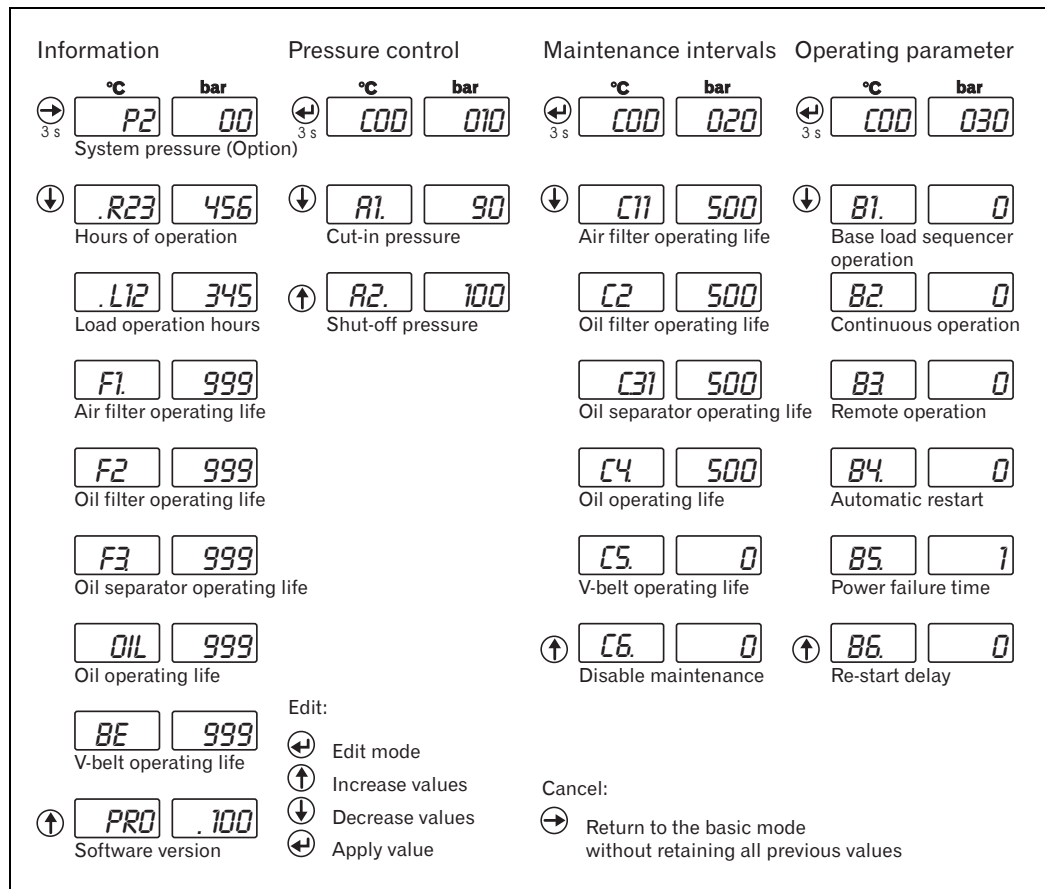

Fig. 1: Menu structure, customer menu

Operating instructions

Inspection and servicing

6 Inspection and servicing

6.1 Safety instructions

The inspection and servicing may be carried out by experts or trained persons only.

- Switch the compressor off for all servicing work, and protect the unit against unintentional operation.
- Prior to any servicing work set the power switch to off or remove the mains plug.
- Use original BLITZ parts and approved operating material only.
- After having completed the servicing work tighten all screws again.
- Depressurise the compressor prior to any servicing work.
- Touch the compressor system at the on and off switch only during and shortly after operation. Permit the compressor to cool down prior to any servicing work. Hot surfaces can cause severe injuries.

Before commencement of work, the following steps must always be carried out.

- Close cut-off valve at compressed air outlet 25 (see fig. 1: component overview).
- Shut down the system.
- Switch off power switch.
- Open slowly the screw plug of the compressed air aftercooler 26 to release air pressure.
- Wait until no more air exits the post-cooler, and tighten the screw plug.
- Wait until the remaining system is released from pressure and has cooled down.
- Unscrew oil filler neck 18 by approx. 1 turn to check whether pressure has been released completely.
- Wait until no more air exits the oil filler neck 18, and tighten again oil plug.

6.2 Checking and topping up the oil level



Danger

Scalding hazard by draining hot oil.

- Slowly open the oil filler neck.
- Avoid skin contact with hot oil

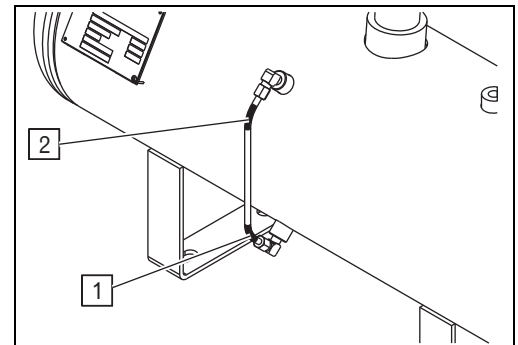

Fig. 5: Oil level indication

- 1 min. mark
- 2 max. mark

Checking the oil level

- Switch the compressor off and depressurise.
- Drain off the condensation water before you check the oil level (refer to chapter 6.5 "Draining the condensation water").
- Unscrew oil filler neck 18 (see fig. 1: Component overview) by approx. 1 turn to check whether pressure has been released completely.
- Check oil level through oil gauge 17 (see fig. 1: component overview).
- The oil level has to be within the min. / max. level.
- Check whether the oil has a milky discoloration or contains water drops (for measures, please refer to chapter 8 titled "Trouble shooting / Milky colour of the oil, water drops in the oil").

Operating instructions

Inspection and servicing

Topping up oil



Do not mix different types of oil. Exclusively use types of oil specified by BLITZ.

- Switch the compressor off and depressurise.
- Carry out the above steps as described in the "Checking oil level" section.
- Remove oil filler neck 18.
- Slowly fill in the oil until the oil level as indicated by the oil gauge 17 is within the min. / max. range.
- Screw on the oil filler neck.

Types of oil

On account of the high stress the lubricating oil is exposed to in screw compressors with oil injection cooling, we recommend to use BLITZ special purpose oils with AFS (anti foam system) additives showing an extremely good aging and water-repellent behaviour; these oils do not foam, and they are anticorrosive.

The degree of viscosity of the oil chosen should be based on the ambient temperature according to ISO 3448.

| | Ambient temperature | |
|--|---------------------|------------------------------|
| | 0 up to +25°C | Permanently higher than 25°C |

| Viscosity class | ISO VG 46 | ISO VG 68 |
|--------------------|--|--------------------------------|
| Viscosity at 40 °C | 41 up to 51 mm ² /s | 61 up to 75 mm ² /s |
| Point of ignition | > 200°C | |
| Pour point | At least 5°C below lowest ambient temperature. | |

Tab. 5: Types of oil



We assume no warranty unless the lubricants used in our screw compressors show these essential characteristics.

6.3 Changing the oil



Danger

Scalding hazard by draining hot oil.

- Slowly open the oil filler neck.
- Avoid skin contact with hot oil



Used oil has to be disposed of according to the local environmental regulations.

- Switch the compressor off and depressurise.
- Place a suitable collecting vessel under the oil and condensation water drain valve 15.
- Open oil and condensation water drain valve 15 while it is at operating temperature.
- Drain the oil into the vessel.
- Close oil and condensation water drain valve 15.
- Open oil filler neck 18 and fill in the new oil slowly (refer to chapter 6.2 "Types of oil") until the oil level as indicated by the oil gauge 17 is within the min. / max. range.
- Screw on the oil filler neck.

6.4 Changing oil filter



Danger

Scalding hazard by draining hot oil.

- Carefully and slowly remove the oil filter.
- Avoid skin contact with hot oil



Use only new oil filters; you cannot clean a used oil filter.

If you replace the oil filter while the oil circuit is filled, up to 2l oil can escape the system.

Dispose of the oil filter according to the applicable local environmental regulations.

Operating instructions

Inspection and servicing

- Place a suitable collecting vessel under the oil filter 24.
- Turn the oil filter left using chain pliers to screw it off.
- Clean the oil filter holder.
- Screw down the new oil filter until the gasket is firmly in place.
- Replace oil that has escaped by new oil (refer to chapter 6.2 "Checking and topping up the oil level").

6.5 Draining the condensation water



The condensation water contains oil and has to be disposed of according to the local environmental regulations.

Drain the condensation water every week.

- Place a suitable collecting vessel under the oil and condensation water drain valve 15.
- Open oil and condensation water drain valve 15 while it is at operating temperature.
- Drain the condensation water into the vessel until pure oil escapes.
- Close oil and condensation water drain valve 15.

6.6 Cleaning the oil cooler and the compressed-air aftercooler.

- Blow compressed air through the cooling fins of the oil cooler 27 and of the compressed-air aftercooler 26 (see fig. 1: Component overview) from the inside of the machine until dust and deposits have disappeared.

6.7 Checking safety valve



The safety valve 11 (see fig. 1: Component overview) is secured with a seal which must not be removed.

- Lift slightly the valve cap to check the function.

6.8 Changing oil high-precision separator cartridge



Use only a new oil high-precision separator cartridge; you cannot clean a used high precision separator cartridge.

A small amount of oil can escape as you change the oil high-precision separator cartridge.

Dispose of the oil high-precision separator cartridge according to the applicable local environmental regulations.

- Turn the oil high-precision separator cartridge 3 (see fig. 1: Component overview) left using chain pliers to screw it off.
- Clean the oil high-precision separator cartridge holder.
- Oil slightly the O-ring and the gasket of the new oil high-precision separator cartridge.
- Screw down the new oil high-precision separator cartridge until the gasket is firmly in place.

6.9 Checking and changing the suction filter cartridge

- Remove the cover of the suction filter 23 (see fig. 1: Component overview).
- In case of severe soiling, immediately replace the suction filter (cf. list of BLITZ spare parts in the chapter titled "Technical annex").
- Refit the cover of the suction filter.

Operating instructions

Inspection and servicing

6.10 Clean proportional controller nozzle.



Applies only to systems equipped with proportional control.

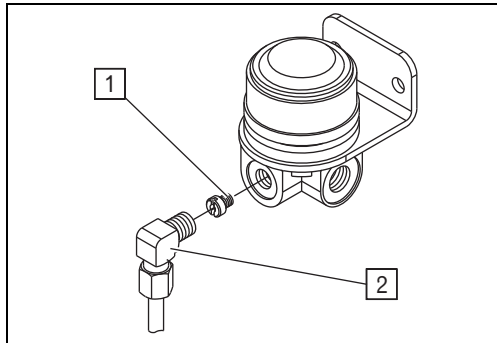

Fig. 6: Proportional controller

- 1 Nozzle
- 2 Hose connection

- Remove plastic hose connection of the proportional controller 7 (see. fig. 1: Component overview).
- Unscrew the nozzle behind.
- Clean nozzle, controller and hose.
- Screw in the nozzle.
- Fix the hose connection again.

6.11 Cleaning drain restrictor

The drain restrictor is where the drain line 9 enters the casing of the compressor 1 (see fig. 1: Component overview).

- Remove the drain line 9 from the drain restrictor.
- Unscrew the restrictor from the casing of the compressor 1.
- Clean the hole of the restrictor.
- Mount and connect the restrictor again.

6.12 Checking and adjusting the V-belt

MONSUN up to 7.5 kW

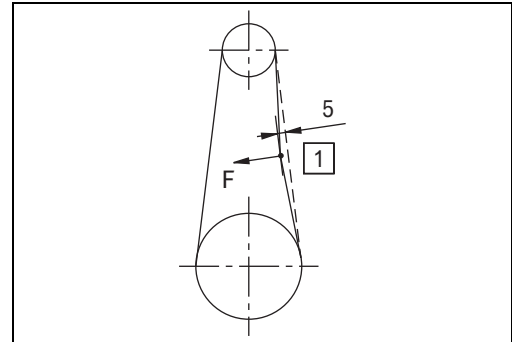

Fig. 7: Checking V-belt tension MONSUN up to 7.5 kW

- Apply a perpendicular force between 25 N and 35 N in point 1 using a dynamometer.
- In doing so, the belt must give approx. 5mm.

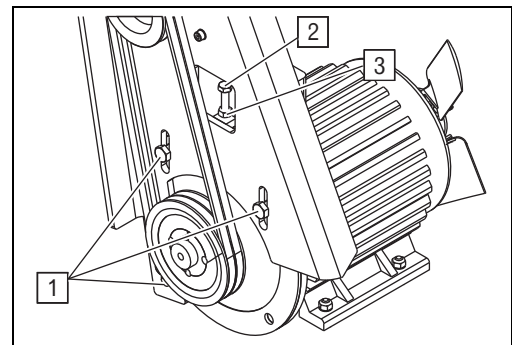

Fig. 8: MONSUN V-belt tensioning device up to 7.5 kW

- 1 Motor flange screws
- 2 Adjusting screw
- 3 Lock nut
- 4 Nut

- Slightly loosen motor flange screws 1.
- Loosen lock nut 3 at adjusting screw 2.
- Adjust V-belt tension through adjusting screw 2 and tighten lock nut 3 again.
- Tighten motor flange screws 1.

Operating instructions

Inspection and servicing

MONSUN up to 7.5 kW

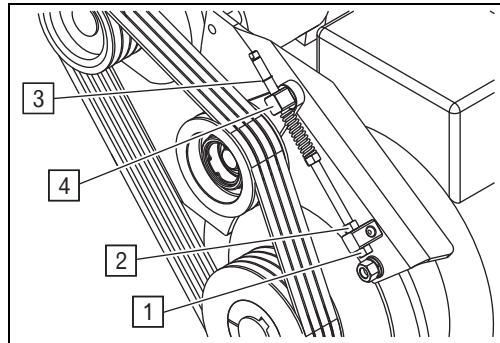

Fig. 9: MONSUN V-belt tensioning device over 7.5 kW

- 1 Bottom adjusting nut
- 2 Top adjusting nut
- 3 Lock ring
- 4 Square pin

The V-belt tension must be corrected if the lock ring 3 touches the square pin 4.

- Loosen the bottom adjusting nut 1.
- Unscrew the top adjusting nut 2 until the distance between the lock ring 3 and the square pin 4 is 10-12mm.
- Tighten the bottom adjusting nut 1.

6.13 Notes on systems equipped with water cooling system

In water-cooled screw compressors, the oil / air cooler is replaced by a plate heat exchanger, and the air-to-air cooler is replaced by a tube bundle heat exchanger. You can use fresh water as cooling water. It is recommended to install a sand and a dirt filter before the cooling water preliminary flow.

6.14 Tighten the screw connections.



After first commissioning, check and – if required – retighten all screws.

- Tighten all screw connections in regular intervals.
- In doing so, observe the torque (cf. Tab.: 6: Torques).

| Screw | Maximum torque |
|-------|----------------|
|-------|----------------|

| | |
|------|-------|
| M 8 | 25 Nm |
| M 10 | 50 Nm |
| M 12 | 85 Nm |

Tab. 6: Torques

6.15 Checking electric terminals

- Check and – if required – tighten all electric terminals regularly.

6.16 Relubricating / replacing motor mounting

- Relubricate or replace the motor mounting as specified by the manufacturer (refer to the name plate of the motor).

Operating instructions

Maintenance schedule

7 Maintenance schedule



The intervals mentioned are experimental values. They can differ considerably depending on the application conditions.

| Application | Interval | Before first commissioning | After first commissioning | Every week | 500 h ¹ | 2 000h ¹ | 4 000 h ¹ | 6 000h ¹ | 8 000 h ¹ | 10 000 h ¹ | | | | | | | | | |
|-------------|----------|----------------------------|---------------------------|------------|--------------------|---------------------|----------------------|---------------------|----------------------|-----------------------|--|--|--|--|--|--|--|--|--|
|-------------|----------|----------------------------|---------------------------|------------|--------------------|---------------------|----------------------|---------------------|----------------------|-----------------------|--|--|--|--|--|--|--|--|--|

| | | | | | | | | | | | | | | | | | | | |
|--|---|---|---|---|---|---|---|---|---|---|--|--|--|--|--|--|--|--|--|
| Check the rotating direction (cf. chapter 3.4). | ● | | ● | ● | ● | ● | ● | ● | ● | - | | | | | | | | | |
| Drain the condensation water (cf. chapter 6.5). | | | ● | ● | ● | ● | ● | ● | ● | - | | | | | | | | | |
| Check the oil level (cf. chapter 6.2). | | | ● | ● | ● | ● | ● | ● | ● | - | | | | | | | | | |
| Check the V-belt (cf. chapter 6.12). | | ● | ● | ● | ● | ● | ● | ● | ● | - | | | | | | | | | |
| Clean the proportional controller nozzle (cf. chapter 6.12). | | | ○ | ● | ● | ● | ● | ● | ● | - | | | | | | | | | |
| Change oil (cf. chapter 6.3), mineral (factory-filled). | | | | ● | ● | ● | ● | ● | ● | - | | | | | | | | | |
| Change oil (cf. chapter 6.3), synthetic. | | | | ● | | ● | | ● | | - | | | | | | | | | |
| Replace oil filter (cf. chapter 6.4). | | | | ● | ● | ● | ● | ● | ● | - | | | | | | | | | |
| Check safety valves (cf. chapter 6.7). | | | | ● | ● | ● | ● | ● | ● | - | | | | | | | | | |
| Clean the drain restrictor (cf. chapter 6.11). | | | | | ● | ● | ● | ● | ● | - | | | | | | | | | |
| Clean the oil-aftercooler (cf. chapter 6.6). | | | ○ | | ● | ● | ● | ● | ● | - | | | | | | | | | |
| Check the suction filter cartridge ² (cf. chapter 6.9). | | | ○ | | ● | | | ● | | - | | | | | | | | | |
| Change the suction filter cartridge ² (cf. chapter 6.9). | | | ○ | | | ● | | ● | | - | | | | | | | | | |
| Change the oil high-precision separator cartridge (cf. chapter 6.8). | | | ○ | | | ● | | ● | | - | | | | | | | | | |
| Tighten the screw connections (cf. chapter 6.14). | | ● | | ● | | | | | | - | | | | | | | | | |



Operating instructions

Maintenance schedule

| | | | | | | | | | | | | | | | | | | | | |
|---|--|---|--|---|--|--|--|---|--|--|--|--|--|--|--|--|--|--|--|--|
| Check the electric terminals (cf. chapter 6.15) | | ● | | ● | | | | | | | | | | | | | | | | |
| Relubricate/replace motor mounting (cf. chapter 6.16) | | | | | | | | ● | | | | | | | | | | | | |

| | | | | | | | | | | | | | | | | | | | | |
|---------------------------------|--|--|--|--|--|--|--|--|--|--|--|--|--|--|--|--|--|--|--|--|
| Measures carried out on (date): | | | | | | | | | | | | | | | | | | | | |
|---------------------------------|--|--|--|--|--|--|--|--|--|--|--|--|--|--|--|--|--|--|--|--|

| | | | | | | | | | | | | | | | | | | | | |
|---------------------------------|--|--|--|--|--|--|--|--|--|--|--|--|--|--|--|--|--|--|--|--|
| Measures carried out by (name): | | | | | | | | | | | | | | | | | | | | |
|---------------------------------|--|--|--|--|--|--|--|--|--|--|--|--|--|--|--|--|--|--|--|--|

Key:

- Measure to be carried out:
- Measure to take whenever required.
- Check at the manufacturer's works.
- ¹ The required maintenance and inspection measures must be carried out on a yearly basis if the hours of operation provided are not reached within a year's period.
- ² Check daily in dusty conditions and replace, if and when necessary.

Operating instructions

Trouble shooting

8 Trouble shooting

8.1 Malfunction, compressor generally



Danger

Trouble shooting may be carried out only by trained experts or by staff members of BLITZ Company. In all actions, please observe the fundamental safety instructions (cf. chapter 1), the safety instructions for operation (cf. chapter 4), and the safety instructions for maintenance (cf. chapter 6).

The compressor does not start up.

| Potential reasons | Actions |
|---|---|
| No connection to network. | <ul style="list-style-type: none"> • Check the connection to the mains. |
| Fuse has blown. | <ul style="list-style-type: none"> • Check the electric cable, switching units and the motor. • Use time-lag fuses only. • Replace the fuse. |
| Network pressure is over cut-in pressure. | <ul style="list-style-type: none"> • Reduce the pressure in the network. |
| Defect in the pressure detector or cable break. | <ul style="list-style-type: none"> • Check cable, or replace pressure detector. |
| The motor has broken down. | <ul style="list-style-type: none"> • Check the electric system and the cables. • Replace the motor. |
| Temperature detector of the motor gives a signal. | <ul style="list-style-type: none"> • Refer to table "Temperature detector of the motor gives a signal". |

Temperature detector of the motor gives a signal.

| Potential reasons | Actions |
|---|---|
| Fault at the electric connection. | <ul style="list-style-type: none"> • Check the electric connection for undervoltage and phase failure. • Check the conductor cross section. |
| Ambient temperature is too high. | <ul style="list-style-type: none"> • Improve the room ventilation. • Select a cooler location. |
| Damage on the compressor | <ul style="list-style-type: none"> • Check bearing of the compressor and gear set. |
| Motor gets too hot due to high switching frequency. | <ul style="list-style-type: none"> • Check the pressure switching points. |
| Pressure detector has been set wrongly. | <ul style="list-style-type: none"> • Check the pressure switching points. |
| The clamping connections have come loose. | <ul style="list-style-type: none"> • Retighten the clamping connections. |



Operating instructions

Trouble shooting

The switching frequency of the motor is too high.

| Potential reasons | Actions |
|--|--|
| The compressed-air reservoir is too small. | <ul style="list-style-type: none"> • Use a larger compressed-air reservoir. |
| Pressure detector has been set wrongly. | <ul style="list-style-type: none"> • Check the pressure switching points. |
| Too much condensation water in the compressed-air reservoir / compressed-air duct-work system. | <ul style="list-style-type: none"> • Drain the condensation water (refer to chapter 6.5). • As a preventive measure, fit an automatic condensation water drain system (BLITZ accessories). |

Low delivery – the setpoint pressure is not made.

| Potential reasons | Actions |
|--|--|
| The suction filter is soiled. | <ul style="list-style-type: none"> • Clean the suction filter. • Change the filter cartridge. |
| Pipes and fittings are leaking. | <ul style="list-style-type: none"> • Tighten the screws and fittings. • Replace the seals. |
| Pressure detector has been set wrongly. | <ul style="list-style-type: none"> • Check the pressure switching points. |
| The air demand is higher than the delivery volume of the compressor. | <ul style="list-style-type: none"> • Check the air demand. • Expand the compressed air supply. |

The compressor turns too hot.

| Potential reasons | Actions |
|--|--|
| Ambient temperature is too high. | <ul style="list-style-type: none"> • Improve the room ventilation. • Select a cooler location. |
| The cooling air volume is not available or too low. | <ul style="list-style-type: none"> • The space between fan and wall is too small (cf. chapter 3.1 "Mounting conditions"). • Check cooler for dirt, and clean if necessary. |
| The ultimate pressure is too high. | <ul style="list-style-type: none"> • Check the pressure switching points. |
| Oil level too low. | <ul style="list-style-type: none"> • Top up oil (refer to chapter 6.2 'Checking and topping up the oil level'). |
| Oil cooler is dirty. | <ul style="list-style-type: none"> • Clean the oil cooler. |
| Oil thermostat / thermostat is defective (only in case of water cooling) | <ul style="list-style-type: none"> • Replace oil thermostat / thermostat. |

Operating instructions

Trouble shooting

Milky colour of oil, water drops in the oil.

| Potential reasons | Actions |
|---|---|
| Water accumulation in the oil vessel (operating temperature is not reached because of too short operation time) | <ul style="list-style-type: none"> • Change the oil immediately. • Retrofit a standby heating (BLITZ accessory item). • Select warmer location. • Check design of the compressor. • Contact manufacturer as to oil specifications. |
| Water accumulation in the oil vessel (caused by humid conditions). | <ul style="list-style-type: none"> • Change the oil immediately. • Select dry location. |

The oil consumption is too high.

| Potential reasons | Actions |
|---|---|
| The wrong oil has been used. | <ul style="list-style-type: none"> • Check the type of oil (cf. chapter 6.2 "Types of oil"), and replace, if and when necessary. |
| The compressor is too hot. | <ul style="list-style-type: none"> • See Table "Compressor turns too hot". |
| Oil escapes through oil high-precision separator cartridge. | <ul style="list-style-type: none"> • Check suction – compressor stage. • Check oil grade. |

Air escapes when the compressor is at rest

| Potential reasons | Actions |
|--------------------------------------|---|
| Pressure control valve is defective. | <ul style="list-style-type: none"> • Replace pressure control valve. |

The compressor is not relieved when switched off.

| Potential reasons | Actions |
|---|--|
| Pressure detector or relief valve is defective. | <ul style="list-style-type: none"> • Check pressure detector and relief valve at intake regulator and replace if necessary. |

The system shuts suddenly down

| Potential reasons | Actions |
|------------------------|--|
| Oil level too low. | <ul style="list-style-type: none"> • Refill oil (refer to chapter 6.2 'Checking and topping up the oil level'). |
| Oil filter is clogged. | <ul style="list-style-type: none"> • Replace oil filter cartridge. |



Operating instructions

Trouble shooting

System fails to shift to no-load operation or fails to shut down.

| Potential reasons | Actions |
|--------------------------------------|---|
| Pressure control valve is defective. | <ul style="list-style-type: none"> • Replace pressure control valve. |

Safety valve blows off

| Potential reasons | Actions |
|---|---|
| Pressure detector is set at a too high rate. | <ul style="list-style-type: none"> • Correct settings of pressure sensor. |
| Pressure sensor is defect. | <ul style="list-style-type: none"> • Replace pressure sensor. |
| Safety valve is defective. | <ul style="list-style-type: none"> • Replace safety valve. |
| Suction stop valve does not close completely. | <ul style="list-style-type: none"> • Check springs of the suction stop valve. |
| Solenoid valve is defective. | <ul style="list-style-type: none"> • Replace solenoid valve. |
| Oil high-precision separator cartridge is used up. | <ul style="list-style-type: none"> • Replace oil high-precision separator cartridge. |
| Proportional controller nozzle is clogged (only with proportional control). | <ul style="list-style-type: none"> • Clean proportional controller nozzle. |

System is operating but is producing no pressure

| Potential reasons | Actions |
|---|--|
| Membrane in the adjust cylinder of the reducing damper is defective (depending on the type of compressor) | <ul style="list-style-type: none"> • Replace membrane and check control pressure in the pressure control valve. |
| The relief valve is defective. | <ul style="list-style-type: none"> • Replace relief valve. |
| Pressure control valve is leaky. | <ul style="list-style-type: none"> • Replace pressure control valve. |

Abnormal noises

| Potential reasons | Actions |
|---|---|
| "Whistling" sound caused by compressed air escaping the supply network, fittings etc. | <ul style="list-style-type: none"> • Remedy leaking points. • Replace the seals. • Tighten the screw connections. |
| The safety valve is "crackling". | <ul style="list-style-type: none"> • Check pressure settings. • Check and replace if necessary safety valve. |
| Fan is knocking. | <ul style="list-style-type: none"> • Check whether the fan does not scrape. |
| Grinding noises | <ul style="list-style-type: none"> • Damage in the mounting, compressor needs repair. • Damage in the mounting, motor needs repair (BLITZ service). |

Operating instructions

Trouble shooting

8.2 Malfunction, PROCON control



Any malfunction will cause the compressor to shut down. This will last until the cause of the malfunction is eliminated and the corresponding message is acknowledged:

- Press key 6 (→) to enter the basic mode.
- Keep then both keys 4 and 5 (↑/↓) pressed for at least 2 seconds.

| Message | Type of malfunction | Cause |
|---------|--------------------------------|--|
| E01 | Final temperature | The value set under "Final temperature error" has been reached or exceeded. |
| E02 | Emergency stop | Emergency stop key 4 has been pressed; or cable break. |
| E03 | Temperature of the motor. | The temperature of the motor winding is too high; or cable break. |
| E04 | Direction of rotation | Wrong direction of rotation; or cable break. |
| E05 | Start temperature | The final temperature is not higher than the value set under "Start temperature". |
| E06 | Development of system pressure | The system pressure has not been developed within the set period. V-belt may have broken. |
| E07 | Excess pressure | The maximum allowable system pressure has been exceeded. |
| E08 | Temperature sensor | Defect in the temperature sensor or cable break. |
| E09 | Network pressure sensor | Defect in the network pressure detector or cable break. |
| E10 | System pressure sensor | When parameter "System pressure sensor" = 1 and system pressure sensor is defective; or cable break. |
| E11 | Shutdown maintenance | At least one maintenance interval has been exceeded by more than 100h and parameter active. |
| ErE | EEPROM parameter | At least one parameter is outside the valid setting range or EEPROM is defective. |
| ErA | EEPROM adjustment | Adjusted values of the analogue sensors are incorrect. |

Operating instructions

Trouble shooting

8.3 Warnings, PROCON control



In case of a warning, the compressor is not shut down automatically. The message is acknowledged in the same fashion as with malfunction.

| Message | Type of malfunction | Cause |
|------------------|----------------------------------|---|
| A01 | Final temperature | The value set under "Final temperature error" (-5°C) has been reached or exceeded. If Error final temperature is active the warning is reset automatically. |
| A02 ¹ | Air filter differential pressure | Air filter is clogged; or cable break. |
| A03 | Oil filter differential pressure | Oil filter is clogged; or cable break. |
| A04 ¹ | Separator differential pressure | Defect in the oil separator; or cable break. |
| A11 | Air filter service life | Maintenance interval for the air filter has elapsed. |
| A12 | Oil service life | Maintenance interval for the oil has elapsed. |
| A13 | Oil filter service life | Maintenance interval for the oil filter has elapsed. |
| A14 | Separator service life | Maintenance interval for the separator has elapsed. |
| A15 | V-belt service life | Maintenance interval for the V-belt has elapsed. |

¹ Optional



Operating instructions
Trouble shooting



BlitzRotary GmbH

Hüfinger Straße 55
78199 Bräunlingen
DEUTSCHLAND
Telefon +49.771.9233.0
Telefax +49.771.9233.99
info@blitzrotary.com
www.blitzrotary.com

A  **DOVER** COMPANY

