



HydroLift S2

Mobile Column Lift
24V DC Powered

4 Column Lift Capacity 32,800 kg.
6 Column Lift Capacity 49,200 kg.
8,200 kg. per column

⚠ IMPORTANT Reference Safety Requirements for Installation and Service of Automotive Lifts before installing lift.

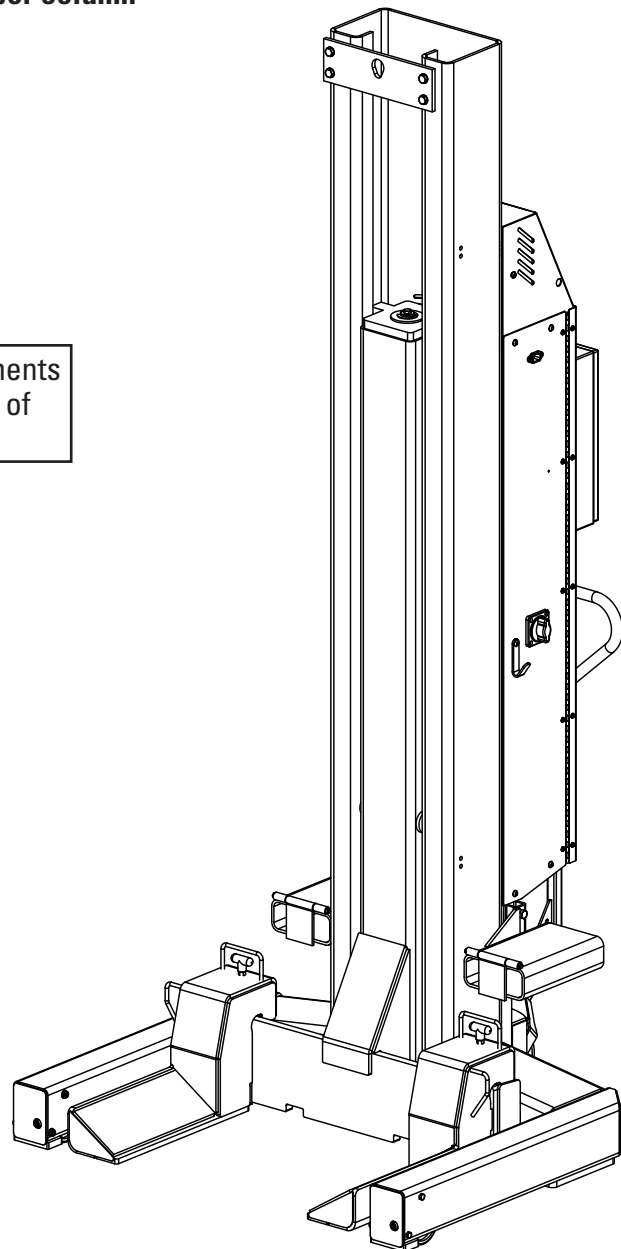

I
N
S
T
A
L
L
A
T
I
O
N
-
S
A
F
E
T
Y
-
O
P
E
R
A
T
I
O
N
-
M
A
I
N
T
E
N
A
N
C
E

EC Declaration of Conformity

according to EU machine directive 2006//42/EG (Annex II A)

Name and address of manufacturer: BlitzRotary GmbH
Hüfinger Str.55
78199 Bräunlingen, Germaany

This declaration only relates to the machine in condition as supplied; components added and/or subsequent modifications made by the end user are disregarded. This declaration becomes invalid if the product is changed or modified without permission.

We declare that the undermentioned machine,

Product name: Lift for vehicles

Serial / type name: HydroLift S2

Machine/serial number:

Year of manufacture: 20...

complies with all relevant provisions or the machine directive 2006//42/EG.

In addition the machine complies with the provisions of the directives 2014/30/EU e electro-magnetic compatibility (safety objectives were complied with according to Annex I, no. 1.5.1 machine directive 2006/42/EG).

Applied harmonized standards:

EN 1493:2011-02	Vehicle lifts
EN ISO 12100:2011	Safety of machinery – Basic concepts
EN 60204-1:2009	Electrical equipment of machines
EN 349:2008-09	Safety of machinery – Minimum gaps
EN ISO 13850:2016-5	Safety of machinery – Emergency stop
EN ISO 13849-1:2016-06	Safety-related parts of control systems TT1
EN ISO 13849-2:2013-02	Safety-related parts of control systems TT2

Other applied technical standards and specifications:

DGUV Grundsatz 308-002	Inspections of lifts
DGUV Regel 100-500	Operation of work equipment
DGUV V3	Accident prevention regulation electric equipment and production equipment

EU prototype examination no.:D 006 AA38871 01 EU notified body
No. 0124 , DEKRRA certification

Representative for thee compilation of relevant technical documentation

Reinhold Nienhaus, BlitzRotary GmbH, Hüfinger Str. 55, 781199 Bräunlingen

Place, date

Bräunlingen, 02.08.2018

Frank Scherer / Managing Director

Intended use

The lift is intended to be used to lift and lower commercial vehicles for repair, maintenance and cleaning during normal workshop operation.

The lift is only to be used as intended, in technically sound condition according to technical specifications.

The maximum load capacity of one lifting column is 8200 kg and must not be exceeded. The permissible load distribution in or against drive direction is 2:1.

Standing or working under suspended load is permitted.

Misuse

Improper behavior can cause danger to life and health of persons working in the vicinity of the lift. The manufacturer is not responsible for damages caused by use against regulations and misuse.

Prohibited:

- Standing and riding on load and load-bearing equipment.
- Standing or working under the load during lifting and lowering.
- Lifting of vehicles loaded with hazardous goods.
- Lift installation in explosive areas.

The lift

Mode of operation

- The lift is used to lift heavy vehicles for maintenance, cleaning or repair to optimum working height.
- Operation is carried out with a mobile control panel.
- Lifting and lowering the vehicle is carried out in jog mode.
- Electronic controls ensure level lifting of the vehicle.
- The lift columns are movable in vehicle longitudinal direction to adjust for different distances between axles.

Specifications	Value
Lifting System	Inverted Rod Hydraulic Cylinder
Electrical System Battery	24V DC - 2 12V Deep Cycle Batteries Exide: NG27 or NG31
Capacity	8200 Kg. Each Column
Fluid Capacity	11 Liters
Lifting Height (Cylinder Stroke)	1753mm
Lifting Time At Capacity	78 Seconds
Lowering Time At Capacity	54 Seconds
AMPS	152-160
Motor	3kW
Number of Cycles (At Full Charge)	14 Cycles At Capacity
Suspension	Simple Spring Load Poly On Steel (Legs) And Glass Filled Nylon (Steering) Wheels With Sealed Roller Bearings And Adjustable Height
Fork Adjustment Positions	5
Relief Pressure	190 Bar
Working Pressure	184-186 Bar
Shipped Weight	730 Kg.
Concrete Floor Slope	20 MPa Min. Strength Min. 115mm Thick 10.5mm Per Meter Side To Side 21.0mm Per Meter Fore To Aft
Noise Level [db(A)]	80
Ambient Temperature	5.. 40°C

Index

Set-Up Instructions	2	Battery Charging	11
Safety Instructions	5	Maintenance Instructions	12
Owner/Employer Responsibilities	5	Trouble Shooting	13
Quick Start Operating Instructions	7	Lift Lockout/Tagout Procedure	14
Emergency Lowering	9	Wiring Diagram	17
Detailed Operating Instructions	10	Spare Parts Lists	19

Set-Up Instructions

Follow these instructions to ensure a satisfactory set-up and operation of the lift.

- After set-up and inspection of the lift, please return this booklet to the literature package and give to lift owner/operator. Literature package should be kept attached to controls for easy access.

1. Unloading: Mobile Lift System units are shipped in the vertical position.
2. After unloading, remove and discard protective wrapping.

NOTE: Unit is shipped without power unit fluid. Installation of fluid MUST be completed prior to lift operation. Failure to do so will result in air entering the system. The unit will then have to be bled.

3. To move the column, remove protective banding and wheel clamps from wheel jack. The forklift brackets can be removed from the side of the column if desired.

4. Open power unit cover by removing the 3 M8 BHCS (Button Head Cap Screw). Fill power unit tank with ISOAW32 hydraulic oil. Tank capacity is approximately 11.5 liters. Short filling may cause vapor lock to occur.

5. Connect two batteries in location shown, Fig. 1. Different batteries meeting the below specifications may be used but performance can vary.

Recommended Battery Specifications:

12V DC Sealed Deep Cycle Battery

Size 24 Frame Group

80 AH Capacity (At 20 AH Rate)

Stud Terminals with Stainless Steel Wing nuts

Battery wires are clearly marked/labeled inside the unit itself.

Install tie-down straps on batteries as shown.

Close lift and re-install M8 BHCS removed earlier.

After the batteries and fluid have been added, screw M20 bolt and M10 socket head bolts clockwise on wheel jack and front of superstructure to adjust unloaded column ground clearance, Fig. 1. Ground clearance is determined by how far the bolts are turned. When the column is loaded, it will automatically lower to the floor.

⚠WARNING Permit only trained personnel to operate lift. After reviewing these instructions, become familiar with the lift controls by running the lift through a few cycles before loading a vehicle on lift. Observe and heed SAFETY and WARNING labels on the lift.

⚠WARNING This motor has internal arcing or sparking parts. To minimize the Risk of Explosion, DO NOT expose to flammable vapors.

OPERATING CONDITIONS: Lift is not intended for outdoor use or storage and has an operating ambient temperature range of 5°-40°C. This product is intended for indoor use only in a dry location.

DO NOT use lift in a manner other than intended. Included (but not limited to) examples of unapproved uses of the lift are: lifting vehicle by only one side, lifting different axles with a column pair (lifting on the

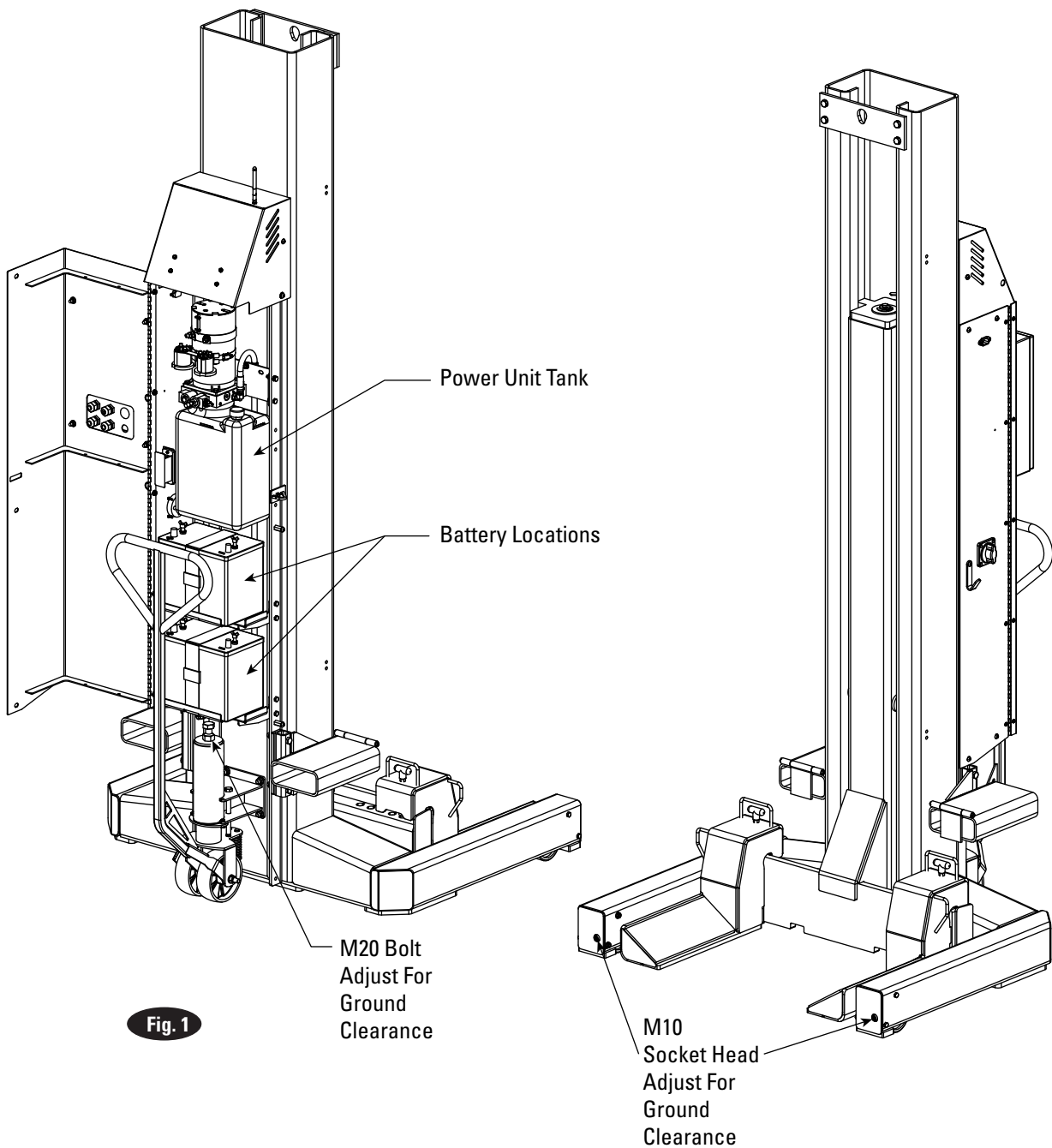

diagonal), and lifting non-approved items.

⚠️ WARNING DO NOT use on asphalt. Lift must be on concrete with a minimum strength of 20.6 MPa and a minimum thickness of 114mm. Maximum allowed floor slope is 10.5mm per meter side to side of vehicle and 21.0mm per meter front to rear of vehicle. DO NOT use on a suspended floor structure without specific

approval from structural engineer.

Ensure tires are properly inflated before lifting. DO NOT exceed tire load rating when raising vehicle.

DO NOT raise/lower only one side of a vehicle.

Lift only on same axle. DO NOT stagger between axles.

DO NOT drive over or pinch electrical cables.

6. Bleed mobile columns:

- a.) Raise forks 150-200mm do not lift forks high enough to engage locks.
- b.) Loosen bleed screw to release air from system.
- c.) Close screw and repeat steps a and b until there is no air in the system and fluid runs clear.

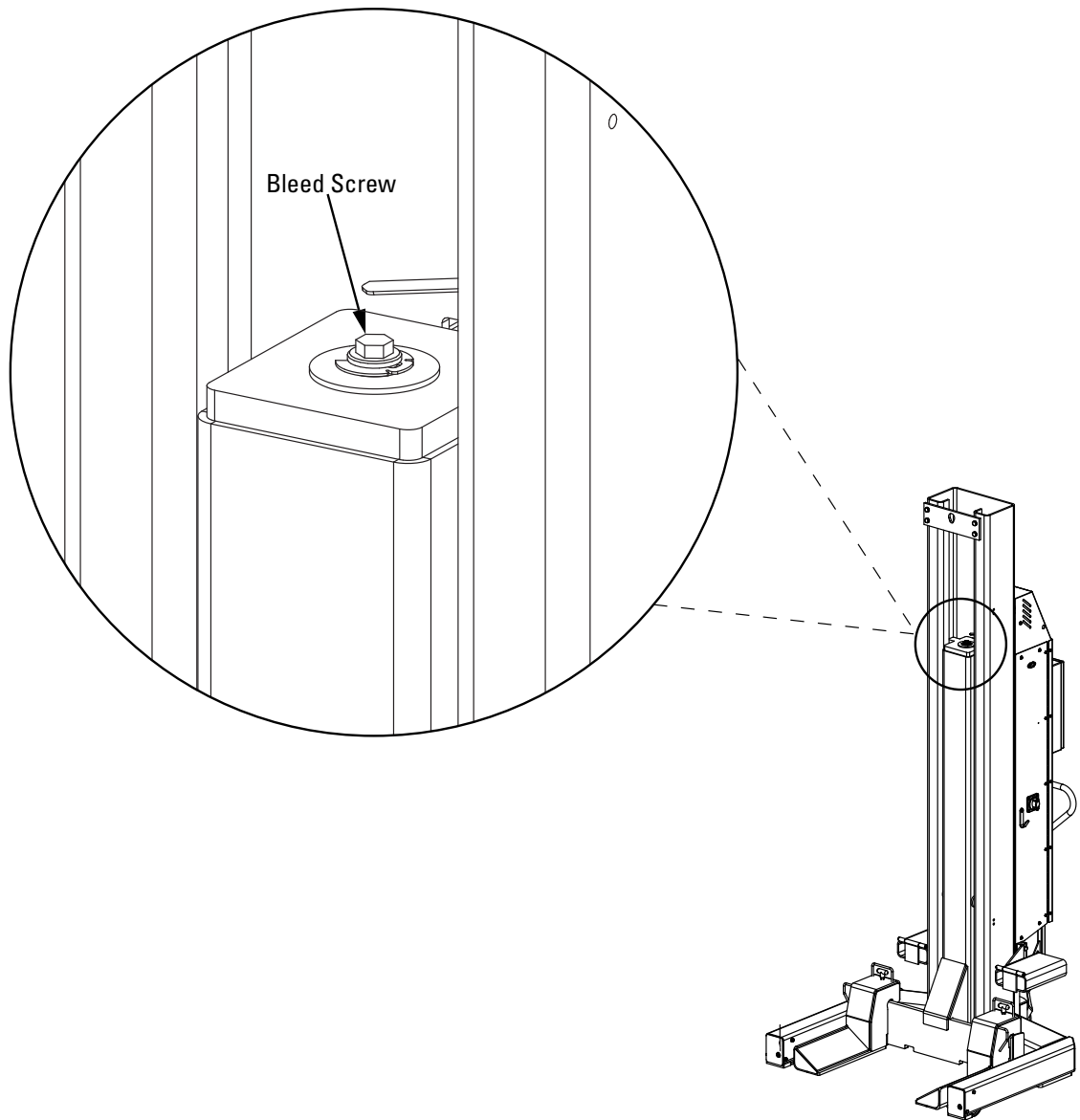

SAFETY INSTRUCTIONS

- Inspect your lift daily. Never operate if it malfunctions or if it has broken or damaged parts. Use only qualified lift service personnel and genuine parts to make repairs.
- Thoroughly train all employees in use and care of lift, using manufacturer's instructions supplied with the lift.
- Never allow unauthorized or untrained persons to position vehicle/lift or operate lift.
- Prohibit unauthorized persons from being in shop area while lift is in use.
- Do Not permit anyone on lift or inside vehicle when it is either being raised or lowered.
- Always keep area around lift free of tools, debris, grease and oil.
- Never Overload lift. Capacity of lift is shown on nameplate affixed to the lift.
- Do Not hit or run over lift forks or base. This could damage lift or vehicle. Before driving vehicle into area, position lift units to provide unobstructed entrance onto lift area.
- Proper lift synchronization requires that all columns have at least a 500kg. load.
- Load vehicle on lift carefully. Position lift forks to fully contact the vehicle tires. Release parking break on vehicle. Raise lift until tires clear the floor. Check lift forks for secure contact with vehicle tires. Raise lift to desired working height.
- Do Not block open or override self-closing lift controls, they are designed to return to the Off or Neutral position when released.
- Remain clear of lift and vehicle when lowering.
- Avoid excessive rocking of vehicle while on lift.
- Clear area if vehicle is in danger of falling.
- Remove tool trays, stands, etc. before lowering lift.
- Position lift units to provide an unobstructed exit before removing vehicle from lift area.
- Do Not perform any maintenance on the control panels until the power has been shut off to the lift.
- Do Not operate equipment with a damaged cord or if the equipment has been dropped or damaged.
- Confirm all lift channels match before operating the lift.
- This lift operates at a sound level of approximately 80 db(A).

The Owner/Employer:

- Shall ensure that lift operators are qualified and that they are trained in the safe use and operation of the lift using the manufacturer's operating instructions; ALI/SM 07-1, ALI Lifting it Right safety manual; ALI/ST-05 ALI Safety Tips card; ANSI/ALI ALOIM-2008, American National Standard for Automotive Lifts-Safety Requirements for Operation, Inspection and Maintenance; ALI/WL Series, ALI Uniform Warning Label Decals/Placards; and in the case of frame engaging lifts, ALI/LP-GUIDE, Vehicle Lifting Points/Quick Reference Guide for Frame Engaging Lifts.
- Shall establish procedures to periodically inspect the lift in accordance with the lift manufacturer's instructions or ANSI/ALI ALOIM-2008, American National Standard for Automotive Lifts-Safety Requirements for Operation, Inspection and Maintenance; and The Employer Shall ensure that lift inspectors are qualified and that they are adequately trained in the inspection of the lift.
- Shall establish procedures to periodically maintain the lift in accordance with the lift manufacturer's instructions or ANSI/ALI ALOIM-2008, American National Standard for Automotive Lifts-Safety Requirements for Operation, Inspection and Maintenance; and The Employer Shall ensure that lift maintenance personnel are qualified and that they are adequately trained in the maintenance of the lift.
- Shall maintain the periodic inspection and maintenance records recommended by the manufacturer or ANSI/ALI ALOIM-2008, American National Standard for Automotive Lifts-Safety Requirements for Operation, Inspection and Maintenance.
- Shall display the lift manufacturer's operating instructions; ALI/SM 07-1, ALI Lifting it Right safety manual; ALI/ST-05 ALI Safety Tips card; ANSI/ALI ALOIM-2008, American National Standard for Automotive Lifts-Safety Requirements for Operation, Inspection and Maintenance; and in the case of frame engaging lifts, ALI/LP-GUIDE, Vehicle Lifting Points/Quick Reference Guide for Frame Engaging Lifts; in a conspicuous location in the lift area convenient to the operator.
- Shall provide necessary lockout/tagout means for energy sources per ANSI Z244.1-1982 (R1993), Safety Requirements for the Lockout/Tagout of Energy Sources, before beginning any lift repairs.
- Shall not modify the lift in any manner without the prior written consent of the manufacturer.

RF Exposure:

A separation distance of 20 cm or more should be maintained between the antenna of the device and persons during device operation. To ensure compliance, operations at closer than this distance is not recommended. The antenna used for this transmitter must not be co-located in conjunction with any other antenna or transmitter.

Notices:

These limits are designed to provide reasonable protection against harmful interference in a residential installation. This equipment generates, uses and can radiate radio frequency energy and, if not installed and used in accordance with the instructions, may cause harmful interference to radio communications. However, there is no guarantee that interference will not occur in a particular installation.

If this equipment does cause interference, which can be determined by turning equipment off and on, the user is encouraged to try to correct the interference by one or more of the following measures: Increase the separation between the equipment. Connect equipment to outlets on different circuits.

Quick Start Operating Instructions

Control Panel Diagram

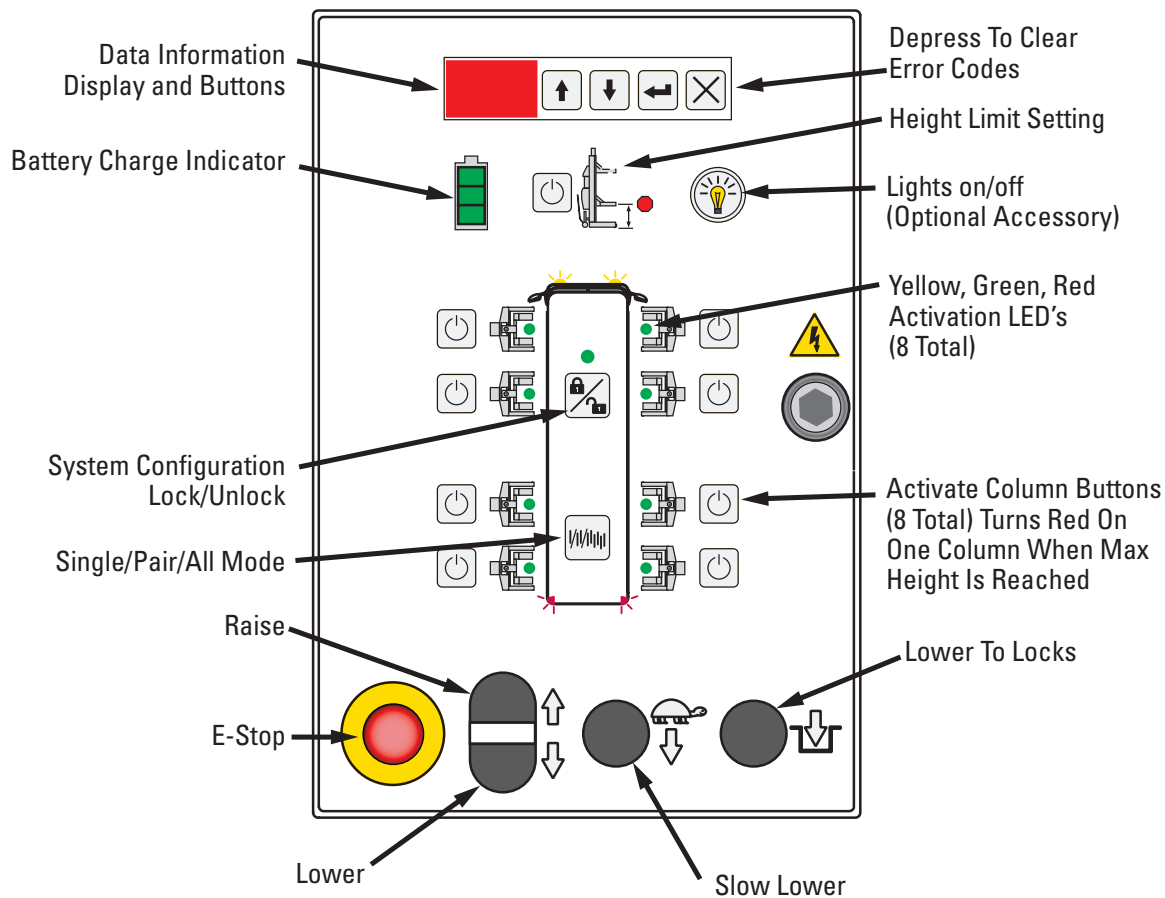

1. The service area must be clear of all personnel before the vehicle is positioned.

⚠ WARNING Locate lift on level concrete surface with a minimum strength of 20.6 MPa.

2. Spotting: Position the vehicle in the location where it is to be lifted.

Note: See Fig. 2 for the general arrangement of each lift column.

3. Loading:
Position one column at a lifting wheel location. Position so that the forks are under the tire and the unit is pushed in as far as possible, Fig. 3. Ensure fork width is adjusted to properly accommodate the tire/wheel size. Turn on the Power Up Switch, Fig. 4.

4. Using the Control Panel and the bus diagram as a reference (see graphic above), press the Activate Column Button relative to the location where the column was just placed. The column will show Green when activated.

5. Position next column at second wheel using loading instructions from step 3.

6. Turn on second column. Again, using the Control Panel and the bus diagram as a reference, press the Activate Lift Button relative to the location of the second column. The lift will show Green when activated. The first lift you activated should now be flashing yellow on your control panel.

7. Repeat step 5 thru 7 for remaining columns. When the entire system of columns is complete, press the System Configuration Lock/Unlock button to lock the lift configuration for operation.

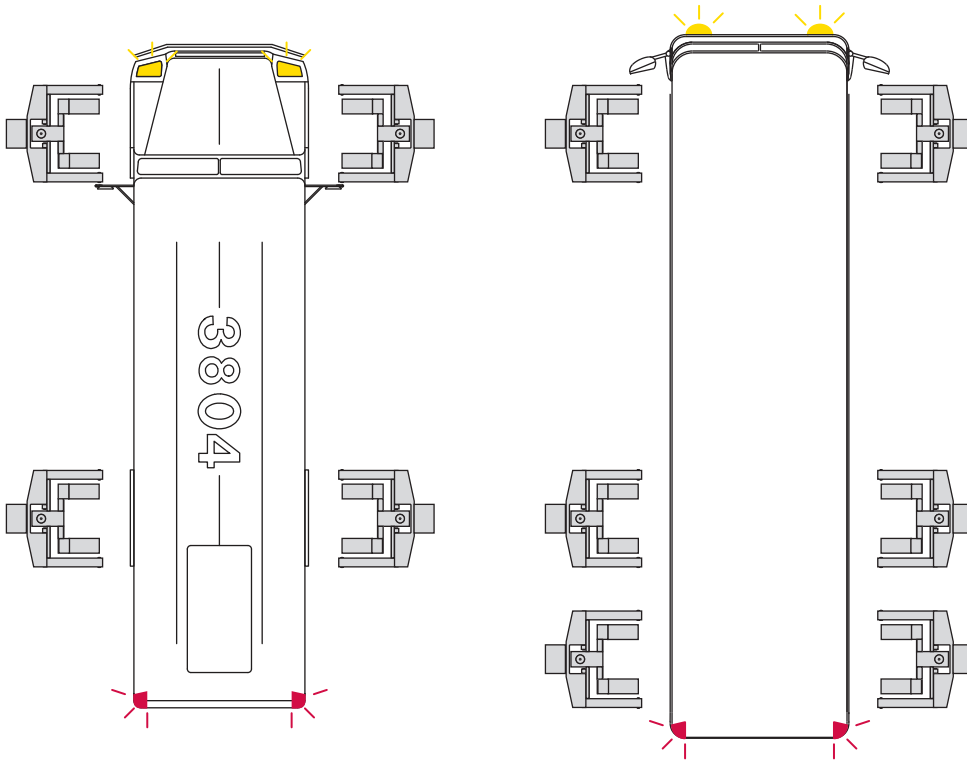

Fig. 2

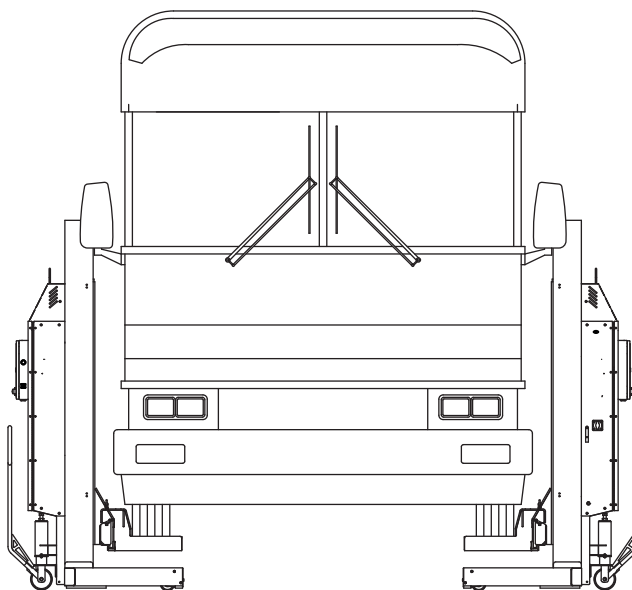

Fig. 3

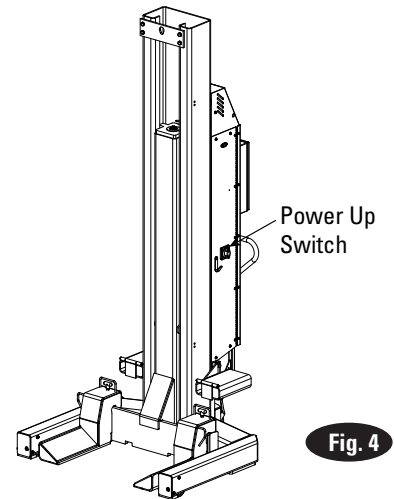

Fig. 4

⚠ WARNING Before attempting to lift any vehicle, be sure that:

- A. Vehicle individual axle weight does not exceed two lift columns combined capacity.
 - B. Lift forks are in secure contact with vehicle tires.
 - C. Adequate overhead clearance is provided to raise vehicle to desired height.
 - D. Parking brake is released on vehicle.
 - E. Adjustable forks must be equally spaced off centerline of lift carriage, and adjusted to properly accommodate the tire/wheel size.
 - F. Ensure tires are properly inflated before lifting. **DO NOT** exceed tire load rating when raising vehicle.
9. To Raise Lift:
- A. Ensuring that the System Configuration Lock/Unlock light is green, press the Raise Button. Raise the vehicle until vehicle tires clear the floor.

Check Fork Contact: Stop and check for secure fork contact with tires, at all columns.

- B. Continue to raise the vehicle to desired height.

NOTE: While cycling the lift, you may observe the individual columns slowing down and speeding up at various stages of travel. This is a normal characteristic of the lift leveling system.

Do Not go under vehicle unless all tires are in secure contact with forks. Lower lift and repeat vehicle and/or lift spotting and loading procedure if required.

- C. Press the Lower To Locks Button to lower columns onto the locking latches.

10. While Using Lift: Avoid excessive rocking of vehicle while on the lift.

11. Before Lowering Lift: Remove tool trays, safety stands, etc. from area.

10.To Lower Lift:

- A. Ensuring that the System Configuration Lock/Unlock light is green, press the Raise Button to raise lifts off the locks.
- B. Press the Lower Button to lower lift. The Slow Lower Button (1/3 speed) can be used if desired. Observe that all columns are lowering and vehicle remains level.
- C. Remain clear of forks and vehicle when lowering. Observe pinch point WARNING decals.
- D. Reset the parking brake.
- E. Move all lift units away from the vehicle to provide an unobstructed exit before removing the vehicle.

Emergency (no power) Lowering:

- During lowering of lifts, ensure that vehicle does not move into an inclined position.
- Lower columns equally.
- Remove tool trays, safety stands, etc. from area.
- Remain clear of forks and vehicle when lowering.

NOTE: In the event batteries become fully discharged, plug the columns into electrical outlet for approximately 30 minutes to achieve adequate charge for one operation cycle. Length may vary based on battery type, condition, etc.

- A. Remove M8 BHCS and open Power Unit Cover. Pull lock open. Pull the Manual Lowering Valve Button and the carriage will begin lowering.
- C. If lift is on locks, slightly lift carriage until lock is free.
- D. Lower each carriage a small increment at a time keeping the vehicle level.
- E. Release the Manual Lowering Valve Button and the downward movement will stop.
- F. After lowering is finished, close and re-install M8 BHCS in Power Unit Cover.
- G. If lift is not operating properly, Do Not use until operation is corrected or repairs are made by qualified lift service personnel.

NOTE: Top cover not shown for clarity.

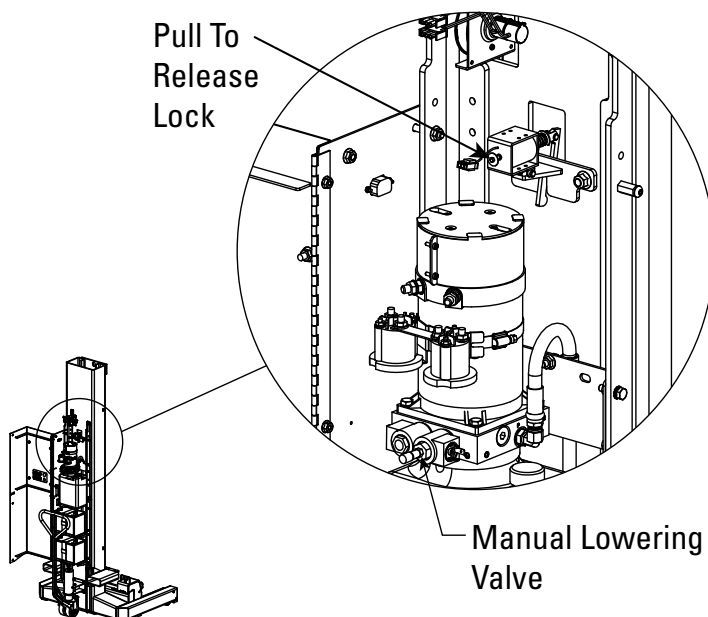

Operating Instruction Details/Options

A. The configuration will not lock if there is not an acceptable pairing of columns. Columns must be paired left/right directly across from one another.

B. In a locked system, pressing the button next to a column on the control panel will toggle the LED between active and inactive states. Active columns are represented as solid green, and inactive columns are represented by blinking yellow. A column will not respond to motion commands when inactive.

Note: The system must be raised and lowered from an active column.

C. In a locked system, the Single/Pair/All Mode Button may also be used to quickly activate and deactivate selected combinations of columns. Pressing the Single/Pair/All Mode Button will toggle through single column mode, column pair mode, and all columns mode.

D. Column LED Indication – Summary of column LED's:
Green – indicates a column ready for motion.
Yellow blink – indicates an inactive column, which does not respond to motion commands until activated.
Red fast flash– indicates a column with an error.

Changing the System Configuration

Columns may only be added to, or removed from, a system by unlocking the existing configuration and then configuring the additional columns as described above. To unlock the configuration press the System Configuration Lock/Unlock Button. Upon pressing the System Configuration Lock/Unlock Button the Green Lock/Unlock LED will go dark and the configuration will unlock. At this time, columns may be safely turned off and removed, and/or replacement or additional columns may be assigned by the same procedure for adding columns as outlined above.

Height Limit Setting

The Height Limit Setting is a user settable stop to limit height travel.

A. To memorize a height stop: Raise all columns to the desired height position. Hold down the Height Limit Setting Button until it begins flashing. Flashing indicates that the height setting has been memorized.

B. Once a height stop has been memorized, press the Height Limit Setting Button to turn the stop on and off. When turned on, the system will stop whenever any column reaches the memorized height stop.

Battery Charging

1. Battery chargers can be plugged in nearly continuously or as needed. Life of the battery can be prolonged if the batteries are charged regularly (for example, after every use), and not allowed to be fully discharged.
2. The supplied battery charger is intended for use with any type lead acid battery, including conventional maintenance free, deep cycle, gelled-type, valve regulated batteries.
3. When batteries are not being charged, the front panel indicator can be used to determine the battery charge level. On the front panel, a yellow light indicates that the battery is partly discharged and should be recharged. A red light indicates that you are near the end of the battery capacity and may not have enough energy left to complete a fully loaded lift cycle; the batteries must be recharged. When the batteries are being charged, the lights on the battery charger will indicate whether the battery is being charged (yellow light) or has reached full charge (green light).
4. Charge time will vary depending on the amount of energy that was discharged. A fully discharged battery will need to be recharged overnight to be fully restored. However, if a single lift is required, a short charge time (such as 30 minutes) should restore the batteries enough for a fully loaded lift cycle.
5. Battery performance will vary depending on the brand of battery selected, the battery specifications, how well the batteries are maintained, and the age of the batteries.

Safety Information

IMPORTANT SAFETY INSTRUCTIONS

KEEP THESE INSTRUCTIONS!

The battery charger is a powerful electrical device. If incorrectly installed, configured or operated, the battery charger can damage batteries and/or electrical equipment. Please read thoroughly the instructions and safety information contained in this manual before operating the battery charger or lift.

⚠ WARNING RISK OF EXPLOSIVE GASES

WORKING IN THE VICINITY OF A LEAD ACID BATTERY IS DANGEROUS. BATTERIES CONTAIN SULFURIC ACID AND PRODUCE EXPLOSIVE GASES. A BATTERY EXPLOSION COULD RESULT IN LOSS OF EYESIGHT OR SERIOUS BURNS. FOR THIS REASON, IT IS OF UTMOST IMPORTANCE THAT YOU FOLLOW THE INSTRUCTIONS EACH TIME YOU USE THE CHARGER.

TO REDUCE THE RISK OF BATTERY EXPLOSION, FOLLOW THESE INSTRUCTIONS AND THOSE PUBLISHED BY THE BATTERY MANUFACTURER FOR ANY EQUIPMENT YOU INTEND TO USE IN THE VICINITY OF THE BATTERY. REVIEW CAUTIONARY MARKINGS ON THESE PRODUCTS AND ON ENGINE, MOTOR OR OTHER EQUIPMENT REQUIRING BATTERY USAGE.

Refer to manual, it contains important safety and operating instructions applicable to the safe and efficient use of your battery charger. To reduce risk of damage to electric plug or cord, pull by the plug rather than the cord when disconnecting the battery charger.

An extension cord should not be used unless absolutely necessary. Use of improper extension cord could result in a risk of fire or electric shock. If extension cord must be used, make sure:

- a) That pins of plug of the extension cord are the same number, size and shape of those of the plug on the battery charger;
- b) That extension cord is properly wired and in good electrical condition;
- c) That wire in extension cord is proper size as follows:

Minimum recommended wire size for various length extension cords used with each battery charger:

Length of Cord in meters	7.5	15	30
Cross Section (mm ²)	1.3	2.5	4.0

Do not operate the battery charger with a damaged cord or plug.

Do not operate the battery charger if it has received a sharp blow, been dropped or otherwise damaged in any way.

Do not disassemble the charger. Incorrect reassembly may result in a risk of electric shock or fire.

To reduce the risk of electric shock, unplug the charger from outlet before attempting any maintenance or cleaning. Disconnecting the leads will not reduce this risk.

To reduce the risk of shock or spark, never touch the ring terminals together while the charger is plugged into an outlet or extension cord.

External connections to the battery charger shall comply with all local, state, and federal regulations.

Maintenance Instructions

⚠ WARNING If you are not completely familiar with automotive lift maintenance procedures Stop: contact factory for instructions.

To Avoid Personal Injury: Permit only qualified personnel to perform maintenance on this equipment.

- Never overload lift. See capacity nameplate.
 - Never direct water stream at control box or cable connections.
 - Never place sharp objects on Communication Cables or drive over cables.
 - Always keep locking latch free.
 - Always keep all bolts tight.
 - Always keep lift and lift area clean.
- Daily
 1. Check locking latch for signs of wear. Make sure latch operates freely.
 2. Check for oil leakage.
 3. Review all cables and cable connections for damage.
 4. Check forks and carriage for damage.
 - Monthly: Check Emergency Stop: Push the "Emergency Stop" button. Columns should be inoperative with any emergency stop button depressed.

- Monthly Lubrication
 1. Lower lift, check oil level in oil tanks on each column: Open Power Unit Cover. If necessary, add ISOAW32 hydraulic oil, until it reaches the full mark on the tank.
 2. Oil the bushings on the jack handle and brake mechanism assembly.
- Monthly: Examine Cords: Check the condition of the charging cord and the communication cords on each column. Replace worn or broken cords as required.
- Every 2 Years: Change Fluid:
 1. Columns must be completely lowered.
 2. Remove cover panel from power unit.
 3. Remove oil from power unit tank.
 4. Refill with approximately 11.5 liters of hydraulic oil meeting ISOAW32 specifications, into each tank.
 5. Check oil level in oil tanks on each column, add if necessary.
 6. Dispose of waste oil according to legal regulations.



TROUBLE SHOOTING

Code	Description	Troubleshooting steps
E0	CPU error	The processor has detected an error. Press "x" to clear. If the problem continues, call for service.
E1	Improper configuration	The column has not been assigned a position, and is connected to a locked system. Press "x" to clear. To add the column to the system, first power down the column, and then unlock the system. Power up the column, assign a position, then re-lock the system.
E2	Improper column pairing	Unless a column is run by itself in single mode, it must be selected and moved with it's pairing column. Press "x" to clear.
E3	Communication Error	1) Check for a loosened or unhooked communication cable. Reattach the cable and press "x" to clear. 2) Check for a powered down column. If one column has been powered down, the other columns must be powered down to re-initialize the system.
E4	Out of Level	One or more columns in the system can not maintain level synchronization 1) Ensure that no columns are hung up on the safety locks 2) Check battery power 3) Check for overloading Press "x" to clear. Individually move each column back into a level position. Once all the columns are level, they may be moved as a group.
E5	Emergency Stop	To restore operation, clear the emergency stop button at the indicated column.
E6	Potentiometer Error	An error has occurred with the string potentiometer, and synchronization can no longer be guaranteed. Follow manual lowering procedures.
E7	Short circuit detected	A short has been detected in the lift actuators. Press "x" to clear. To determine the faulty component, run the faulty column by itself. Press the buttons below in exact order until the error is generated: 1) Up button (Error? Check/replace contactor) 2) Slow lower (Error? Check/replace small lowering valve) 3) Lower to locks (Error? Check/replace large lowering valve) 4) Down button (Error? Check/replace lock solenoid)
E8	Software mismatch	Power down and disconnect the column from the system. Load the column with the newest software code. To check the revision level of the software, insert a service card. Revision level is indicated in the service menus as "r__".
E9	Stuck Key	A stuck keypad button or motion push button has been detected on startup, or a motion push button has been held on for longer than 2-1/2 minutes.
CL	Communication Loss	Communication between columns has been lost temporarily during operation. Re-try operation after release of button.
	Display Unresponsive	Turn off power and check wire connections on the display board for the keypad, the push buttons, and the control board. Restart power and test.
	Slow To Rise	Overloaded, check battery and connections, dirt, debris, in oil system.
	Lift Drifts Down	Dirt, Debris, in oil system.
<p>Receive Signal Strength Indicator (RSSI) (Inside Control Panel)</p> <p>Each transceiver has 3 green LED's near the serial port labeled (RSSI). When operating, these LED's should all be on. If they are not all on this indicates a poor signal do to a transceiver failure or antenna/ antenna cable problem.</p>		

LIFT LOCKOUT/TAGOUT PROCEDURE

Purpose

This procedure establishes the minimum requirements for the lockout of energy that could cause injury to personnel by the operation of lifts in need of repair or being serviced. All employees shall comply with this procedure.

Responsibility

The responsibility for assuring that this procedure is followed is binding upon all employees and service personnel from outside service companies (i.e., Authorized Installers, contactors, etc.). All employees shall be instructed in the safety significance of the lockout procedure by the facility owner/manager. Each new or transferred employee along with visiting outside service personnel shall be instructed by the owner/manager (or assigned designee) in the purpose and use of the lockout procedure.

Preparation

Employees authorized to perform lockout shall ensure that the appropriate energy isolating device (i.e., circuit breaker, fuse, disconnect, etc.) is identified for the lift being locked out. Other such devices for other equipment may be located in close proximity of the appropriate energy isolating device. If the identity of the device is in question, see the shop supervisor for resolution. Assure that proper authorization is received prior to performing the lockout procedure.

Sequence of Lockout Procedure

- 1) Notify all affected employees that a lockout is being performed and the reason for it.
- 2) Unload the subject lift. Shut it down and assure the disconnect switch is "OFF" if one is provided on the lift.
- 3) The authorized lockout person operates the main energy isolation device removing power to the subject lift.
 - If this is a lockable device, the authorized lockout person places the assigned padlock on the device to prevent its unintentional reactivation. An appropriate tag is applied stating the person's name, at least 3" x 6" in size, an easily noticeable color, and states not to operate device or remove tag.
 - If this device is a non-lockable circuit breaker or fuse, replace with a "dummy" device and tag it appropriately as mentioned above.
- 4) Attempt to operate lift to assure the lockout is working. Be sure to return any switches to the "OFF" position.
- 5) The equipment is now locked out and ready for the required maintenance or service.

Restoring Equipment to Service

- 1) Assure the work on the lift is complete and the area is clear of tools, vehicles, and personnel.
- 2) At this point, the authorized person can remove the lock (or dummy circuit breaker or fuse) & tag and activate the energy isolating device so that the lift may again be placed into operation.

Rules for Using Lockout Procedure

Use the Lockout Procedure whenever the lift is being repaired or serviced, waiting for repair when current operation could cause possible injury to personnel, or for any other situation when unintentional operation could injure personnel. No attempt shall be made to operate the lift when the energy isolating device is locked out.

OPERATING CONDITIONS



Lift is not intended for outdoor use and has an operating ambient temperature range of 5°-40°C.

Software Update/Service Card Instructions

Wireless Operation

Software Updates:

To install a software update:

- 1) Power down the column by turning off the disconnect switch.
- 2) Open the control panel door using 11mm socket wrench.
- 3) Place the software update card into the memory card slot on the control board.
- 4) Flip switch down to wireless.
- 5) Turn power on.
- 6) Select from one of 32 system numbers by cycling up and down and pressing enter on the desired channel.
- 7) **Keep in mind that all the columns in a set must have the same channel selected.**
- 8) Press a “**Select Column Button**”   on one of the columns.

Note: A solid green light should come on in that position. Notice the amber light is blinking on other columns already programmed.

- 9) Press a “**Select Column Button**”   on the remaining columns in that set.

Note: Don't press the buttons where there's an amber light. The amber light signifies that another column in that set has taken that position.

- 10) Once the set of columns are configured in a safe (read the safety guidelines included) and desired manner, press the lock button.
- 11) Remove software update card, and close control panel door.

In order to change the channel:

- 1) Turn on or unlock the column set. When powered up or unlocked, the system number should be displayed on the menu screen (e.g. “S1”).
- 2) Press the  key on the menu pad. The system number should then start blinking.

Note: Columns may be added or subtracted when the system is unlocked. Once locked, no columns can be removed, and no outside columns can be added in or control the locked system. Any column that is set to a system number that is already being used by a locked system will display an “E1” error. Always check the column display before locking. If extra columns appear, press the emergency stop and determine the location of the extra columns. Move them to a different system number before locking the system.

- 3) Use the up and down buttons to scroll through the system numbers.
- 4) Press enter once the desired system number is selected
- 5) You must do this for every column in the set ensuring that all the columns have the same system number selected.
- 6) Once the same system number is chosen, operate the column as normal.

Software Menus:

Service menus can be accessed when a service card is placed in the memory card slot.

Menus are displayed on the menu screen and can be scrolled using the up, down, enter, and cancel keys.

Menu Item	Menu Selections	Description
[Height]		Shows current column height (default menu for locked columns)
H		
	HC	Clear max. height setting
	HS	Set max. height setting
P		
	PC	Clear pot calibration
	PS	Set pot calibration
C		
	C0	Configuration recall - turn off
	C1	Configuration recall - turn on
b		
	b0	Lowering Beeper - turn off
	b1	Lowering Beeper - turn on
U		
	UUS	Height display units - US (in)
	USI	Height display units -metric (cm)
rXX		Software revision level XX indicated revision number

- H:** Selecting **HS** sets the maximum height setting. Raise the column to the desired height and depress " ← " once to set the value.
In operation the column that reaches its maximum height first stops all columns in the system. Selecting **HC** clears the maximum height setting.
Depress " ← " once to clear the Max Height Value. The Maximum Height will default to the Stoke Limit Height until a new Maximum Height is set.
- P:** Selecting **PC** clears the full cylinder stroke limit setting. Depress " ← " once to clear the value.
Selecting **PS** sets the stroke limit and height display calibration.
- C:** **C1 (Save/Recall Config at Power Off) or C0 (Erase Config at Power Off)**. Depress " ← " once to select and return. If turned on, upon power-up, the column will recall it's previous column configuration / position assignment.
- b:** **b1 (Beeper ON) or b0 (Beeper Off)**. Depress " ← " once to select. Lowering Beeper function will be active or suppressed accordingly.
- U:** **UUS (Display height in inches) or USI (Display height in centimeters)**. Depress " ← " once to select.

COLUMN WIRING DIAGRAM

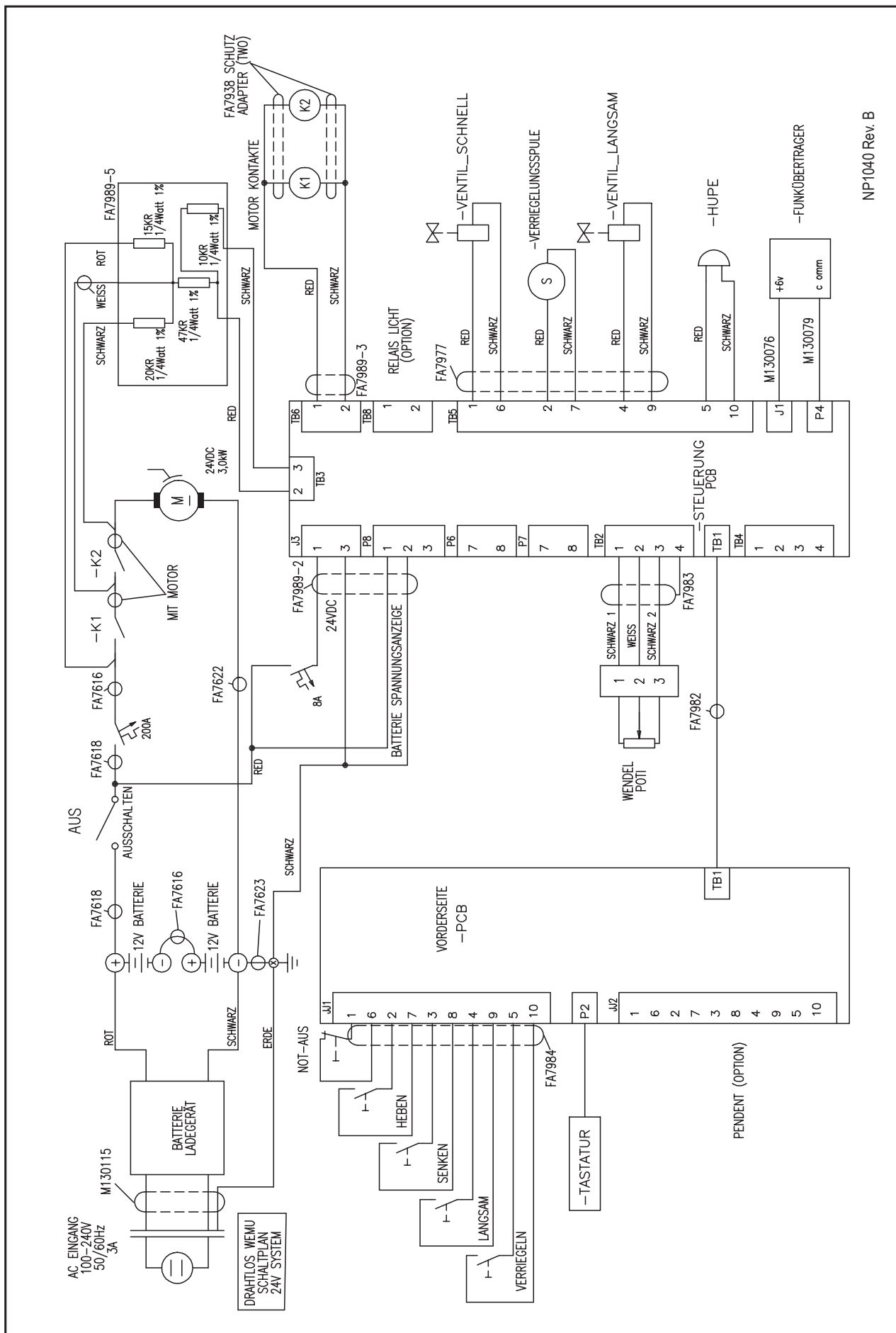

NP1040 Rev. B

HYDRAULIC SCHEMATIC

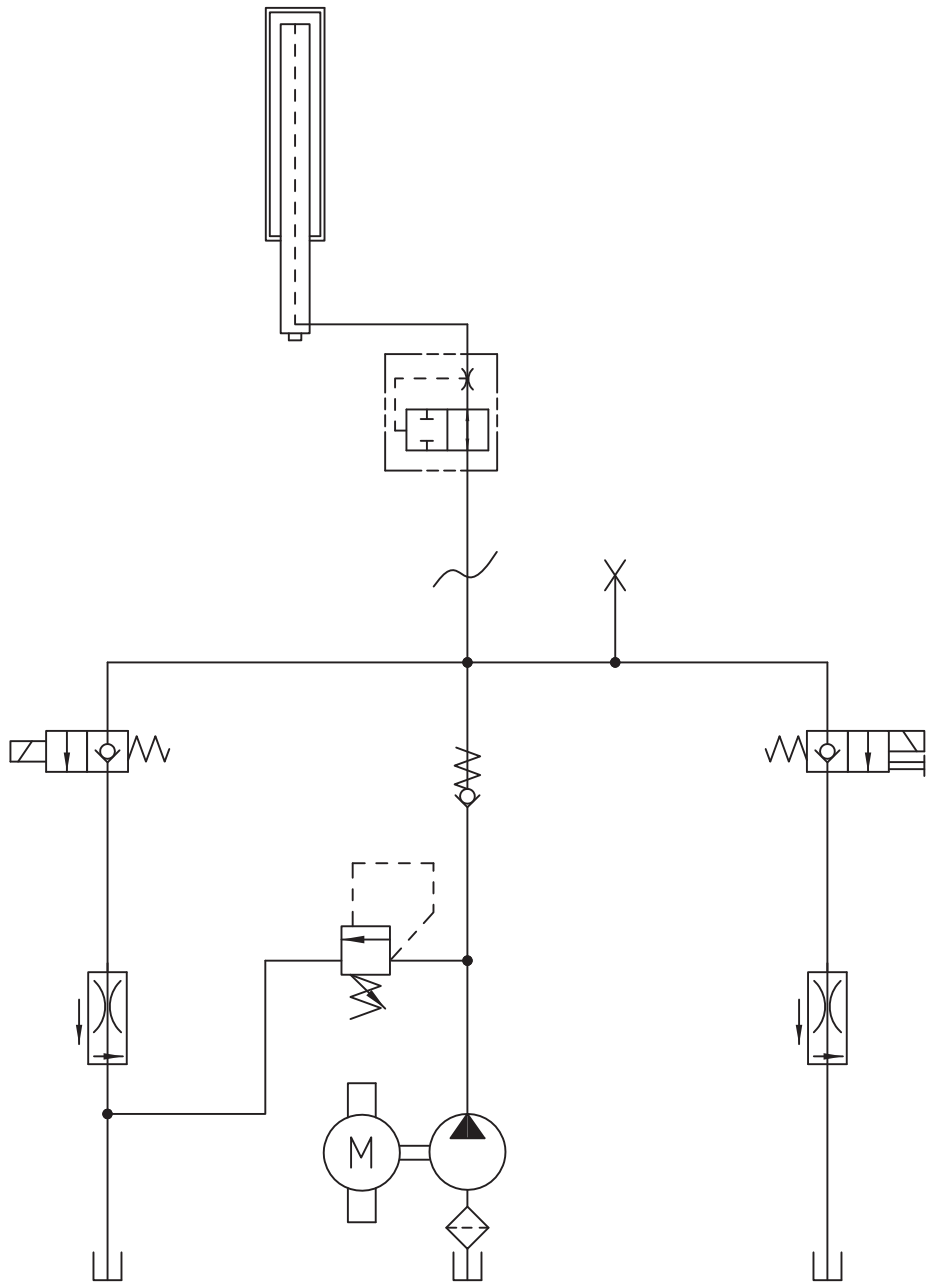

Item	Description	Part No.
1	Control Panel Assembly	M110062
2	Membrane Touchpad	FA7964
3	E-Stop Actuator	FA7962
4	Dual Push Button	FA7958-22
5	Single Push Button	FA7968
6	Audible Single Device	FA7974
7	Control Board	FA7965
8	1/2" Hole Plug	FA7958-9
9	UI Board	FA7963
10	DC Disconnect Switch	FA7958-4
11	Cord Hook	M120189
12	Upper Cover Assembly	M110060
13	Cover Weldment	M120163
14	Side Panel Assembly	M110061
15	RP SMA Jack Bulkhead	M130072
16	RF Antenna	M130074
17	Modem Assembly	M140032
18	Self Drilling Screw	M130112
19	Main Switch Lock	M120347

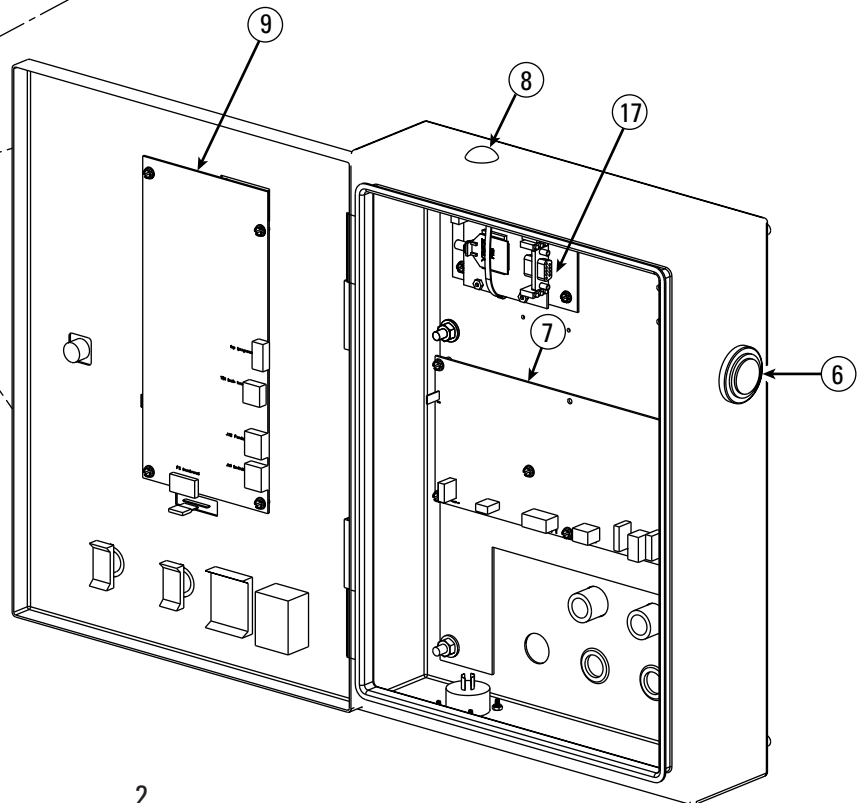
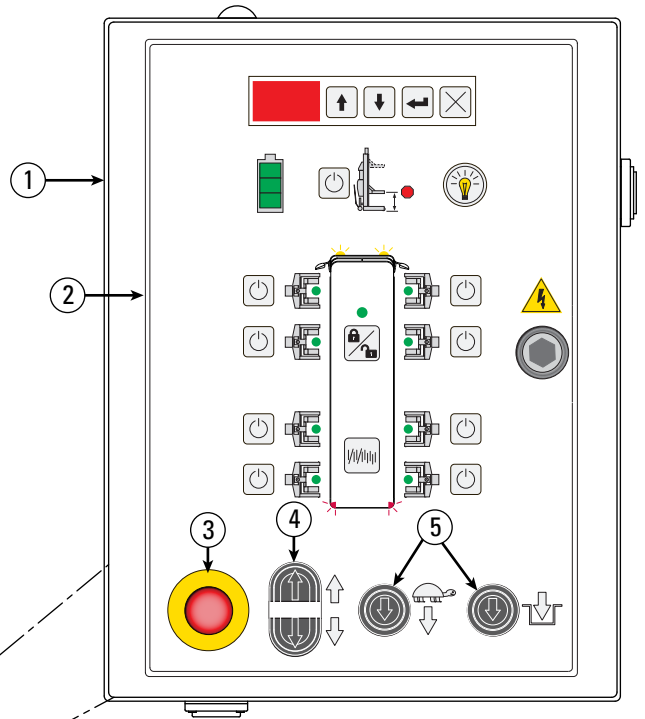
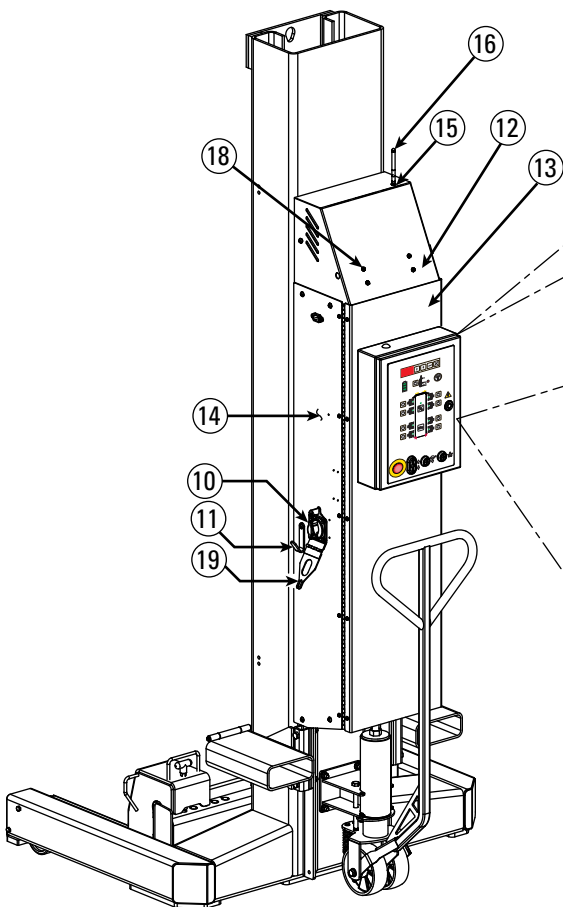

Item	Description	Part No.
1	M6 x 1.0 x 20mm Lg. HHCS, PLTD	41413
2	M12 x 1.75 x 200mm Lg. HHCS Grade 8.8, PLTD	41483
3	M20 x 2.5 x 60mm HHCS Full Thread Grade 8.8, PLTD	M130129
4	M12 Flat Washer	41520
5	M8 x 125 x 30mm Lg. HHCS	41539
6	M8 Flat Washer	41548
7	M8 x 125 Hex Nylon Insert Locknut	41563
8	M12 x 1.75 Hex Nylon Insert Lock Nut PLTD	41568
9	M6 x 1.0 Hex FLGD WZLock Nut	41618
10	Caster Mounting Weldment	M120049Y

11	Caster Clevis Weldment	M120052Y
12	Handle Weldment	M120058Y
13	Caster Retainer Plate	M120075Y
14	Spring Cap Weldment	M120077Y
15	Brake Weldment	M120080Y
16	Link Arm	M120084Y
17	Caster Spring	M130010
18	Caster Wheel	M130101Y
19	UHMW Bearing Sheet	M130019Y
20	Brake Spring	M130020Y
21	Center Handle Bearing	M130021Y
22	Linkage Bearing	M130022Y
23	Outer Handle Bearing	M130026Y
24	Flange Bearing	M130027Y

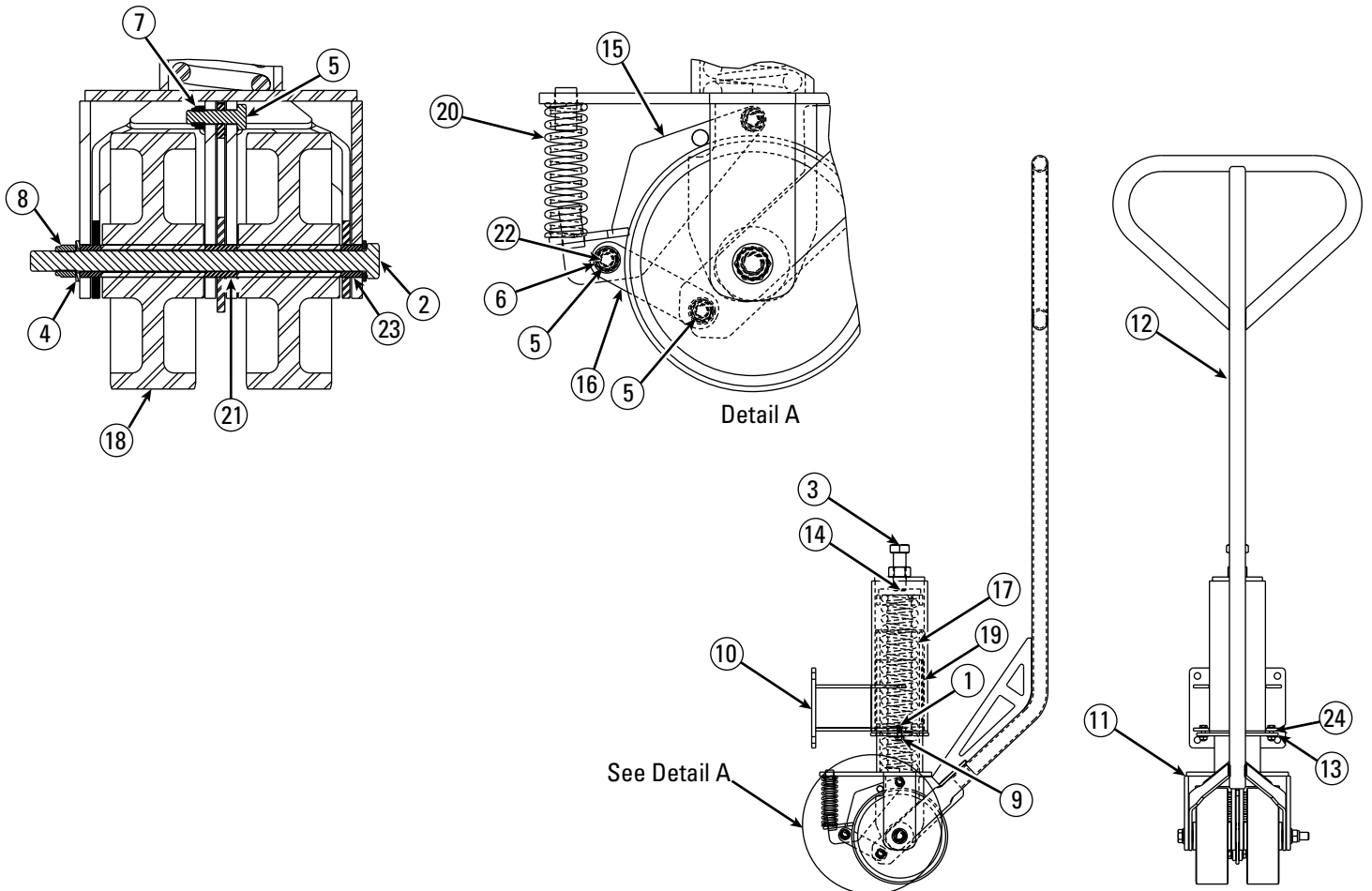

Item	Description	Part No.
1	5/16" SAE Flat Washer, PLTD	40856
2	1/2" SAE Flat Washer	40920
3	1/8" x 1" Lg. Cotter Pin	41200
4	M10 x 1.5 x 35mm Nylon Locking SOC. HD. CS., PLTD	41512
5	Base Weldment	M120138Y
6	Wheel Bracket Weld	M120144Y
7	Pivot Shaft	M120148Y
8	Leg Wheel	M120149Y
9	Floor Roller Shaft	M120150Y
10	Leg Wheel Spring	M120151Y
11	Flanged Bearing	M130030Y
12	RH Fork Assembly	M110011Y
13	LH Fork Assembly	M110010Y
14	Fork Pin Handle	M130013Y
15	Fork Pin Bushing	M130015Y
16	Fork Pin Spring	M120136Y
17	Bolt Collar	M120135Y
18	3/8"-16NC x 5" Lg. Hex SHCS, PLTD	40389
19	3/8"-16NC Hex Nut, PLTD Grade 5	40659
20	Tie Bar	M120045Y
21	M12 Lock Washer	41595
22	M12 x 1.75 x 30mm Lg. HHCS Grade 8.8, PLTD	41684
23	Swivel Nut Elbow #6	M130028
24	9/16" Internal Tooth Lock Washer, PLTD	40998
25	Bulkhead Union Elbow #6	T140138
26	Cylinder Hydraulic Tube	M130009
27	Adapter	FJ7352-3
28	Velocity Fuse	M130016
29	Hydraulic Cylinder	M130001Y
	Cylinder Seal Kit	M130130
30	Roller	M130002Y
31	Carriage Slider	M130006Y
32	Slider	FC5905-4Y

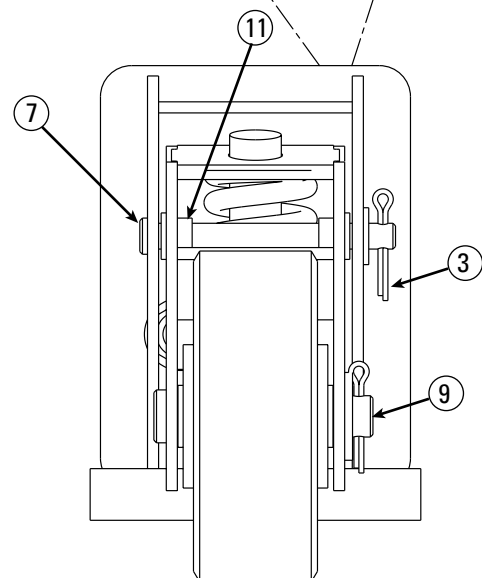
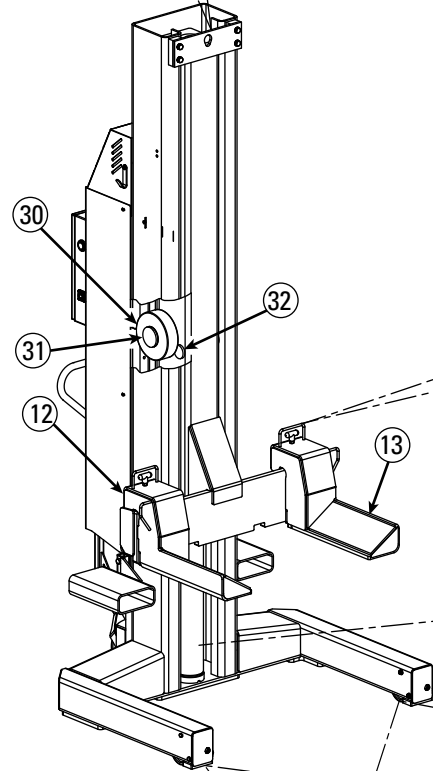
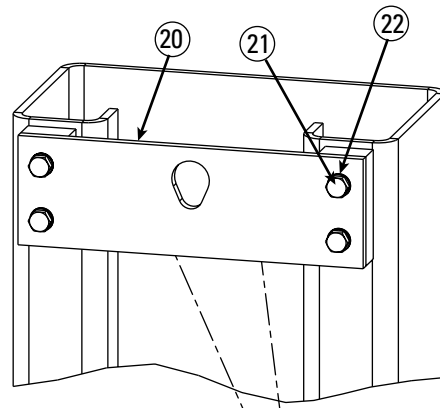

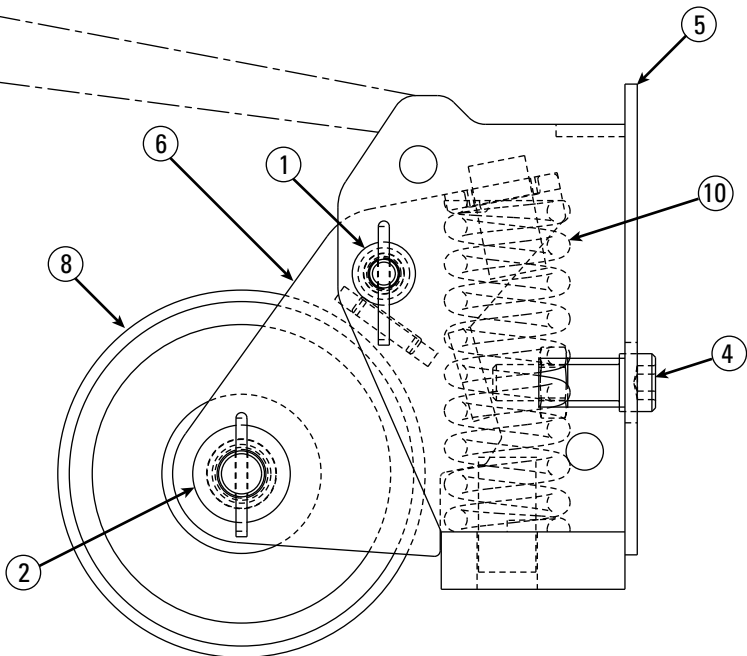
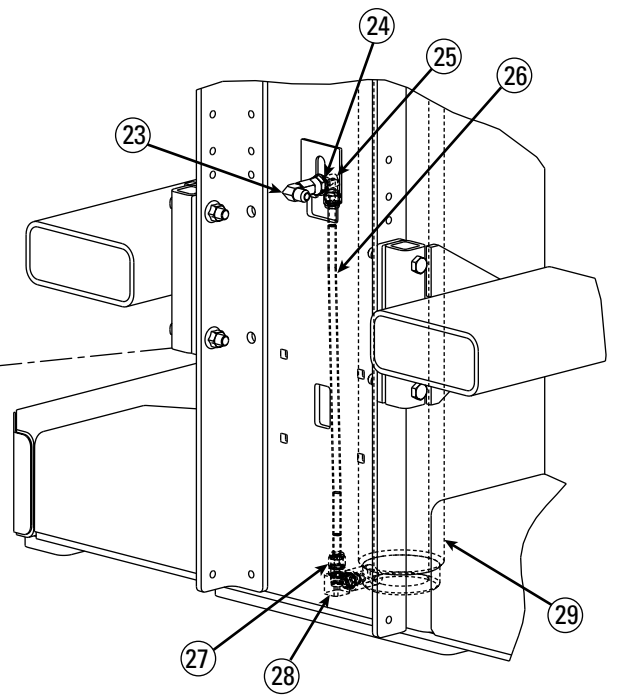
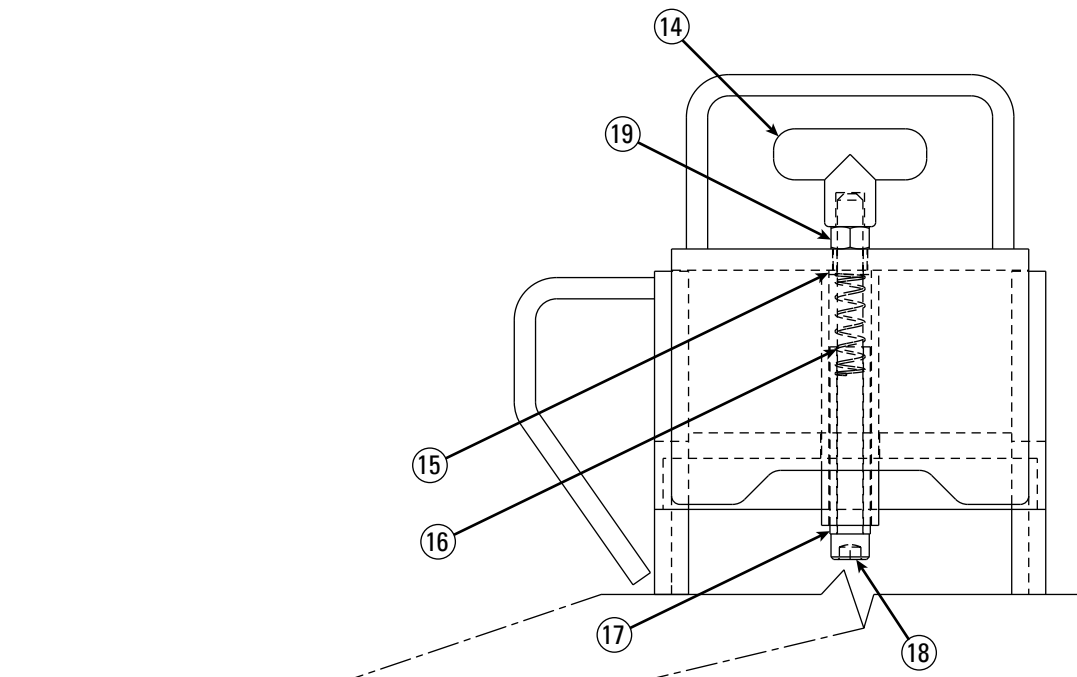

P3576 Power Unit

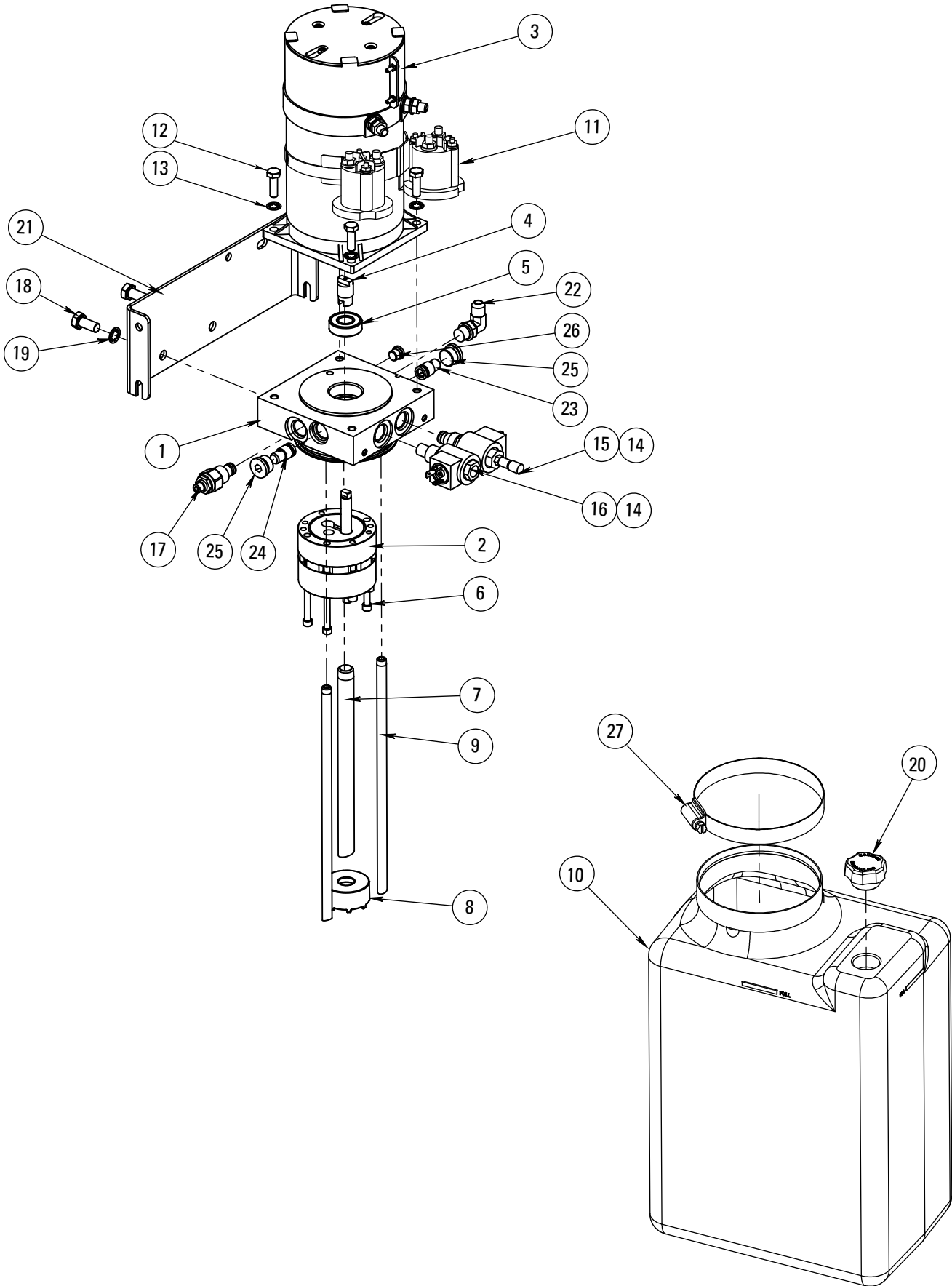

P3576 Power Unit

Item	Description	Part No.
1	Base Assy. M3519,MOD. (2) 2W/2P	P-3570-1
2	P Assy. QM MDLR, DC, BRGS BLD RSV	P-3570-2
3	MOTOR, DC, 24 VOLT 2 TERM	P-3570-3
4	SHAFT, INTERMEDIATE, MOD, SPCL DC	P-3570-4
5	BEARING, MOTOR TO BASE, M-SERIES	P-3570-5
6	SCREW, SHC, 1/4-20 x 3.0, BLK OX.	P-3570-6
7	TUBE, SUCTION, POLY TANK	P3580-14
8	FILTER ASSY. SUCTION, SHROUD	P-3570-8
9	TUBE, RETURN	P3580-10
10	POLY RESERVOIR	P3580-19
11	24V RELAY	M130090
12	SCREW, H.H. CAP, M8-1.25 x 25	P-3570-12
13	WASHER, STAR LOCK, 5/16	P-3570-13
14	COIL, 24VDC, #8, HIRSCHMAN, LOW WT	P-3570-14
15	CARTRIDGE, 2W/2P, NC, POPPET, #8	P3580-7
16	CARTRIDGE, 2W/2P, NC, POPPET, 4000	P3580-8
17	VALVE, RELIEF, PILOT OP, 100-3000	P3580-3
18	SCREW, H.H. CAP, M10-1.50 x 22	P-3570-18
19	WASHER, INTERNAL TOOTH LOCK, 3/8	P-3570-19
20	BREATH-FILLER PLUG, POLY TANK	P3580-21
21	BRACKET, MTG PLT, 3.22 CNTR	P-3570-21
22	FITTING, ELBOW, 90 DEG, 37 DEG	P-3570-22
23	POPPET ASSY, P CMP FL, GPM .75	P-3570-23
24	POPPET ASSY, P CMP FL, GPM 1.5	P-3570-24
25	PLUG, SAE O-RING, 3/4-16, HEX SOC	P-3570-25
26	PLUG, SAE O-RING, 7/16-20 HEX, SO	P-3570-26
27	WORM CLAMP, POLY TANK	P3580-20

**Upper Cover Removed
For Clarity Of View**

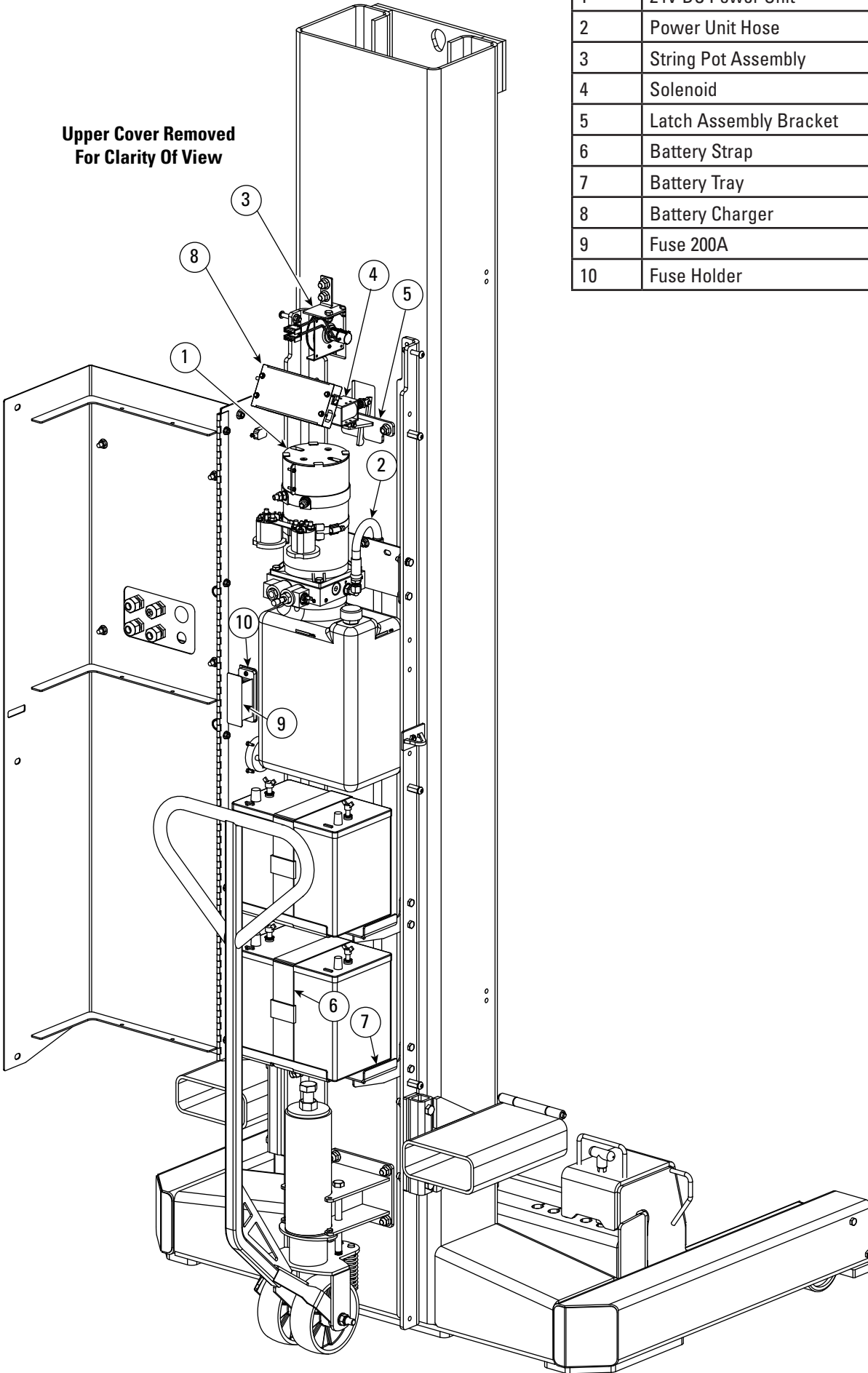

Item	Description	Part No.
1	24V DC Power Unit	P3576
2	Power Unit Hose	M130029
3	String Pot Assembly	M130018
4	Solenoid	M130017
5	Latch Assembly Bracket	M120067Y
6	Battery Strap	M130032
7	Battery Tray	M120167Y
8	Battery Charger	FA7958-48
9	Fuse 200A	FA7958-6
10	Fuse Holder	FA7958-5

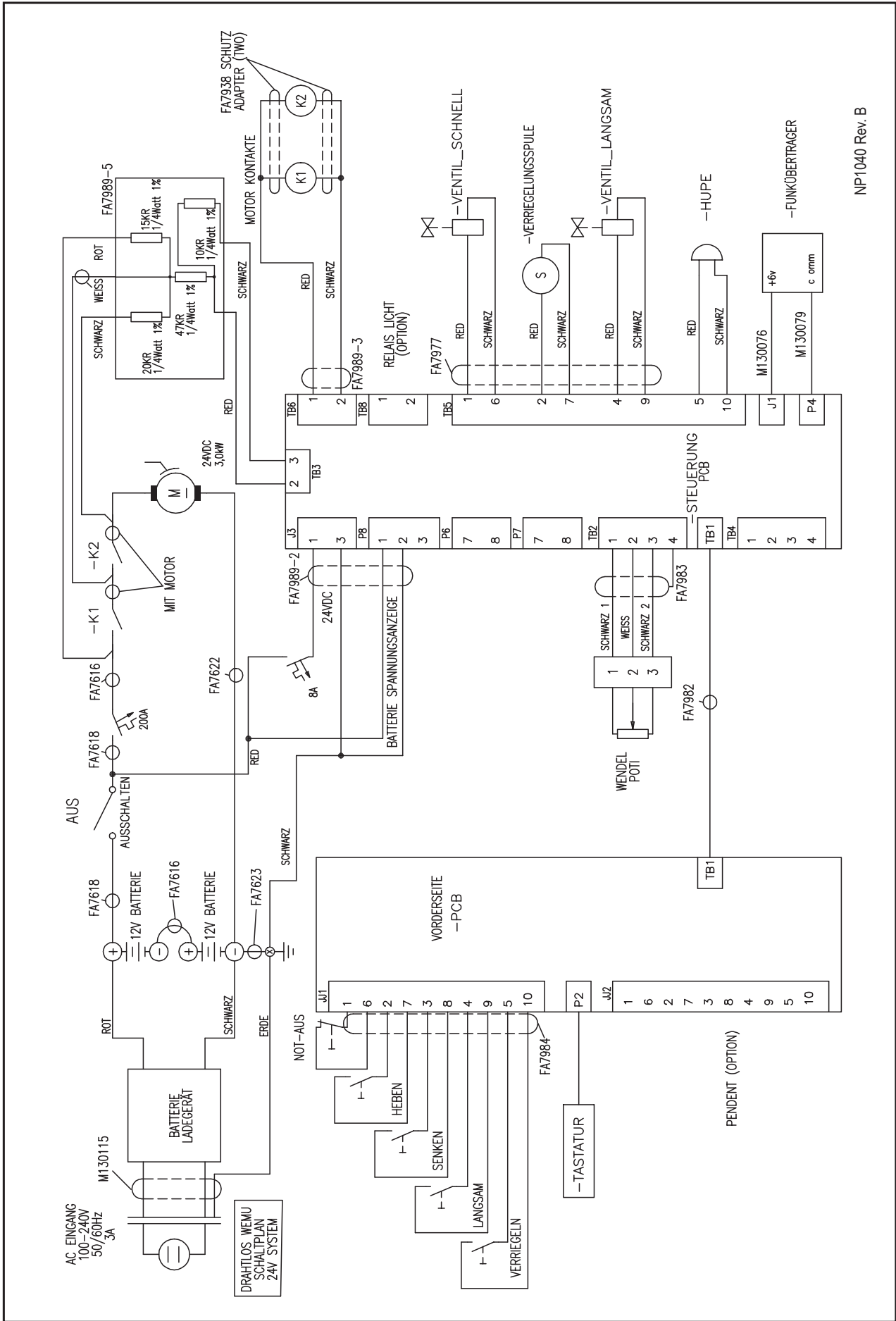

NP1040 Rev. B

NOTES

NOTES

Vehicle Service GroupSM
2700 Lanier Drive
Madison, IN 47250, USA
www.vsgdover.com

BlitzRotary GmbH
Hüfingerring Straße 55
D-78199 Bräunlingen
Telephone +49.771.9233.0
Fax +49.771.9233.99
info@blitzrotary.com
www.blitzrotary.com

© Vehicle Service GroupSM
All Rights Reserved. Unless
otherwise indicated, Blitz[®],
and all other trademarks are
property of Dover Corporation
and its affiliates.

Blitz[®]

