

# PIT LIFTS, SUSPENDED

## 15 T, 800 MM STROKE

The hanging pit lifts from Blitz convince with an exceptionally well thought-out safety concept, combined with ergonomic ease of use – without compromise. This is how we set standards in modern lifting technology.

- + Measuring the pit becomes a minor matter
- + Undercarriage with above-average adjustment range
- + Made in Germany – 125 years' experience in lifting technology

Compact, sturdy design for a reassuring sense of security.

Safely dimensioned – External forces and bending moments are compensated by the large piston rod diameter.

Intuitive operation includes a quick lift via push button, additional load lift by means of an air motor, a fine lift with a pump rod and a lowering via hand lever.

The extra-long cylinder guide ensures that lateral forces can be absorbed, even when loads are outside the center.

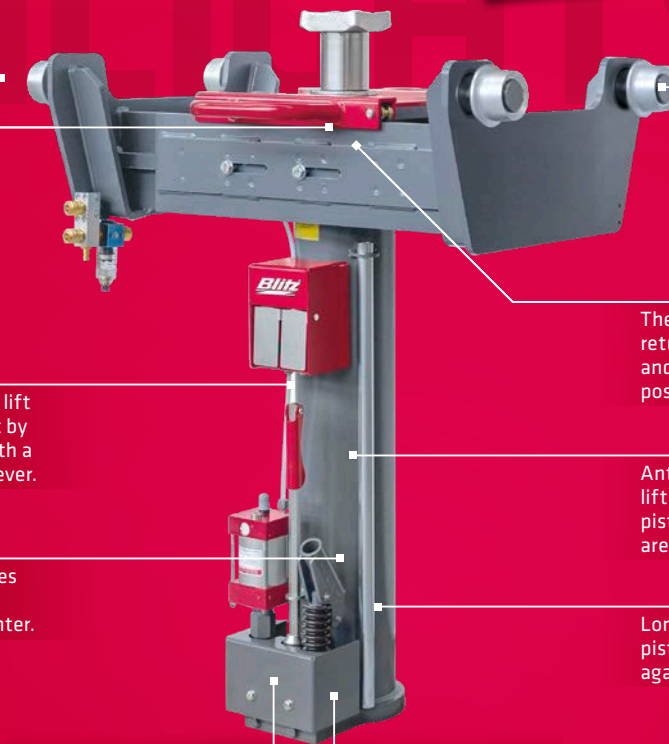

The lifter is delivered with universal castors.

The forced return allows a quick return of the lifting ram with and without load to the lowest position.

Anti-rust prevention – During each lifting and lowering movement piston rod and inner cylinder wall are moistened with oil.

Longevity – Piston rod and pump piston are hard-chrome plated against corrosion and wear.

2 layer coating for perfect corrosion protection.

No disturbing hydraulic hoses installed.

Figure shows Blitz S15 Vario Flat

## HIGHLIGHTS IN DETAIL

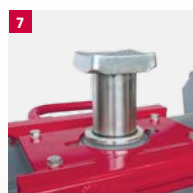
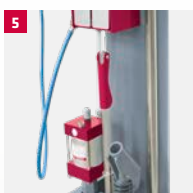

- 1 All important controls are red to prevent incorrect operation
- 2 Handle for moving the lift
- 3 Front-mounted controls and large-scale control buttons, also operable with gloves
- 4 Undercarriage castors are covered against damage
- 5 Pump rod tidily positioned on the lift. The lifting unit lowers by means of spring pack at 250 kg load and secures against slipping
- 6 Needle bearing mounted undercarriage castors with grease nipple
- 7 The piston rod is slightly wetted with oil to protect against corrosion
- 8 Optional: Pneumatic power set with condensate separator and compressed air connections

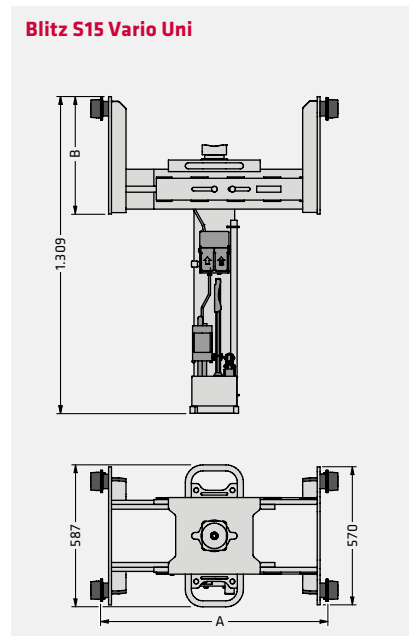
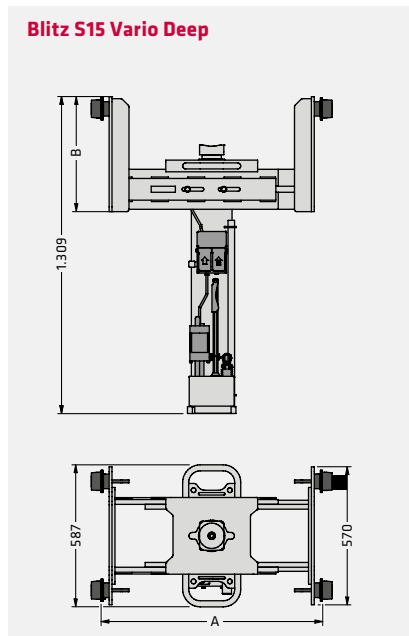
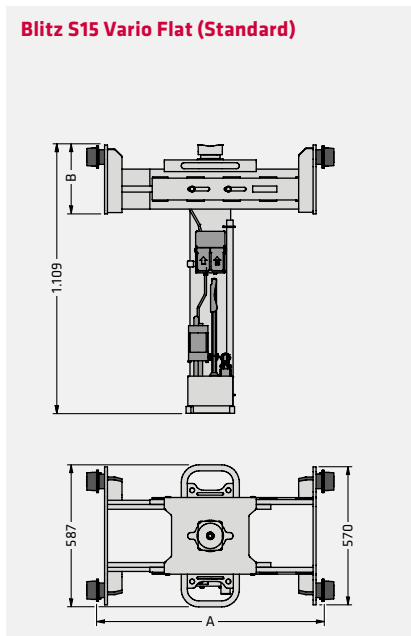

Model	Blitz S15 Vario		
	Flat	Deep	Uni
Capacity	15 t	15 t	15 t
Stroke	800 mm	800 mm	800 mm
Mounting hole	55 mm	55 mm	55 mm
<b>A</b> Undercarriage width	800-1100 mm	800-1100 mm	800-1100 mm
<b>B</b> Undercarriage height	285 mm	485 mm	485 mm
Operating pressure	10 bar	10 bar	10 bar
Weight	285 kg	310 kg	320 kg
Piston rod diameter	80 mm	80 mm	80 mm
Height adjustability	-	-	in steps of 2x 75 mm

# APPLICATIONS

## ACCESSORIES

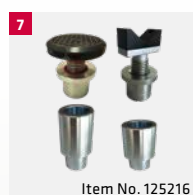
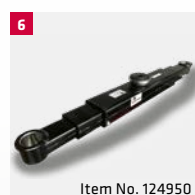
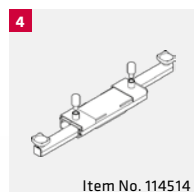
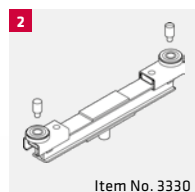

- 1** Traverse ATB Truck Set, 15 t, 55 mm pivot diameter
- 2** Traverse ATB, 15 t, 55 mm pivot diameter
- 3** Traverse ATB NF, 10 t, 55 mm pivot diameter
- 4** Traverse ATEB S2, 15 t, 55 mm pivot diameter
- 5** Transmission plate GA IV, Adjustment angle =  $\pm 12^\circ$ , weight = 23 kg, large contact surfaces made of rubber, straps to secure the load, inclination adjustable on all sides via thread, particularly flat design, galvanized as standard, load capacity 1 t,  $\varnothing$  35 mm, dimensions 530 x 380 x 120 mm
- 6** Traverse ATT 3.2 C, axle traverse 2x extendable, perfect for VW Crafter
- 7** Set of VW Crafter attachment pieces
- 8** Compressed air supply and condensate separator

Technical changes reserved. Data are considered advertisement.  
 Pit-Lift-Suspended-Blitz-S15-Vario-BR-126789-en-2018-07