



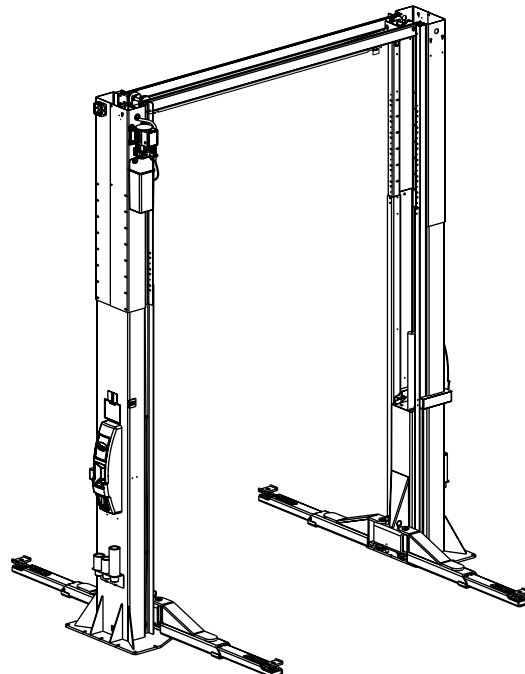
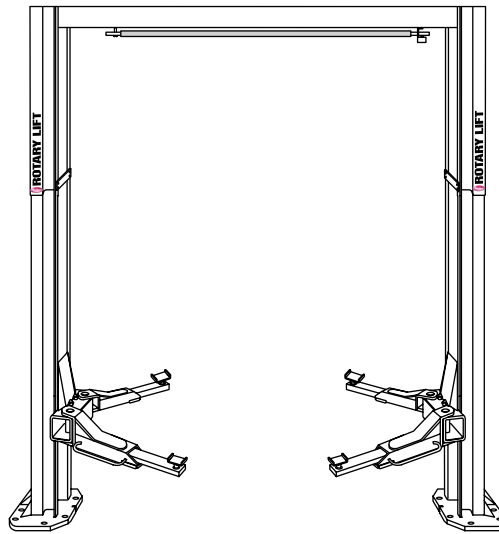
TÜV  
Rheinland

**SP065M** (200 Series Lifts)

**SP065E** (600 Series Lifts)

**Standard Arms Capacity 6500 kg. (14,300 lbs.)**

**Sprinter Arms Capacity 5000 kg. (11,000 lbs.)**



# SP065M Series

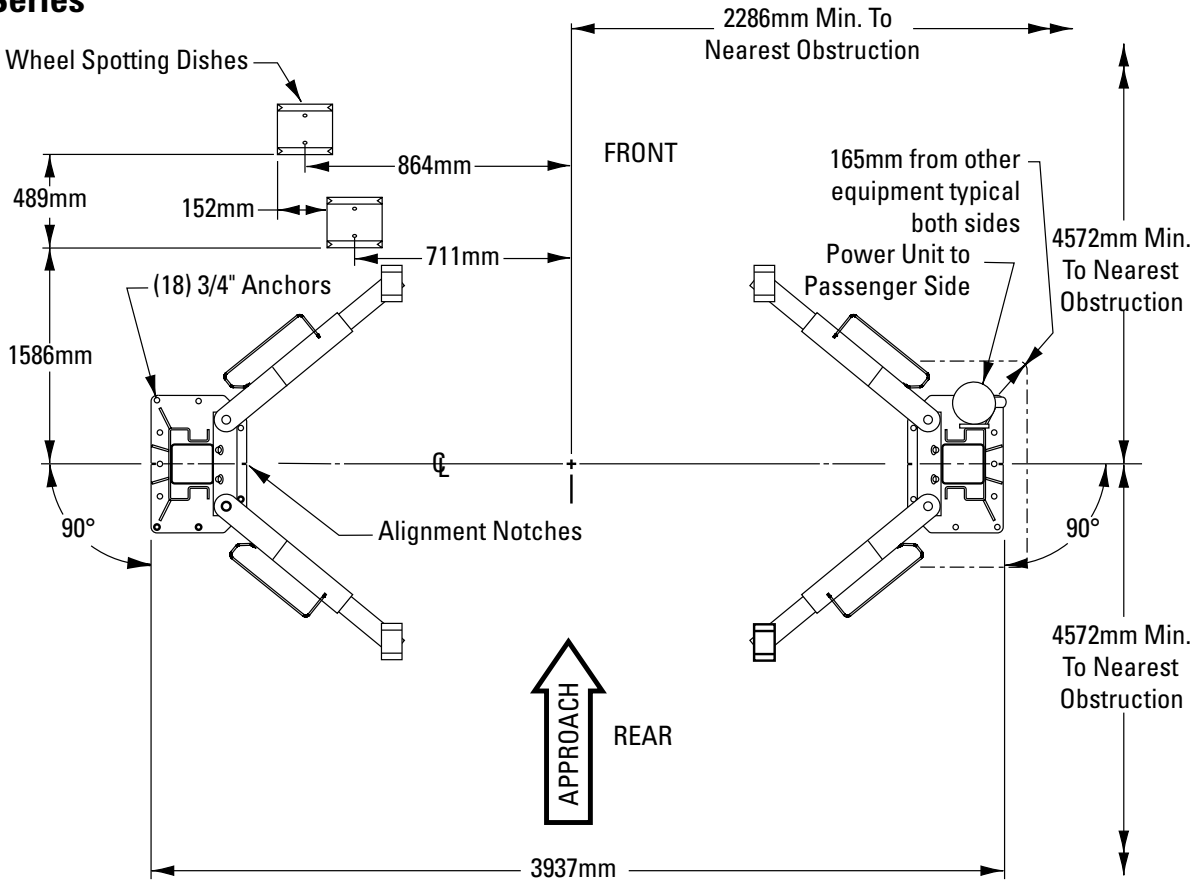
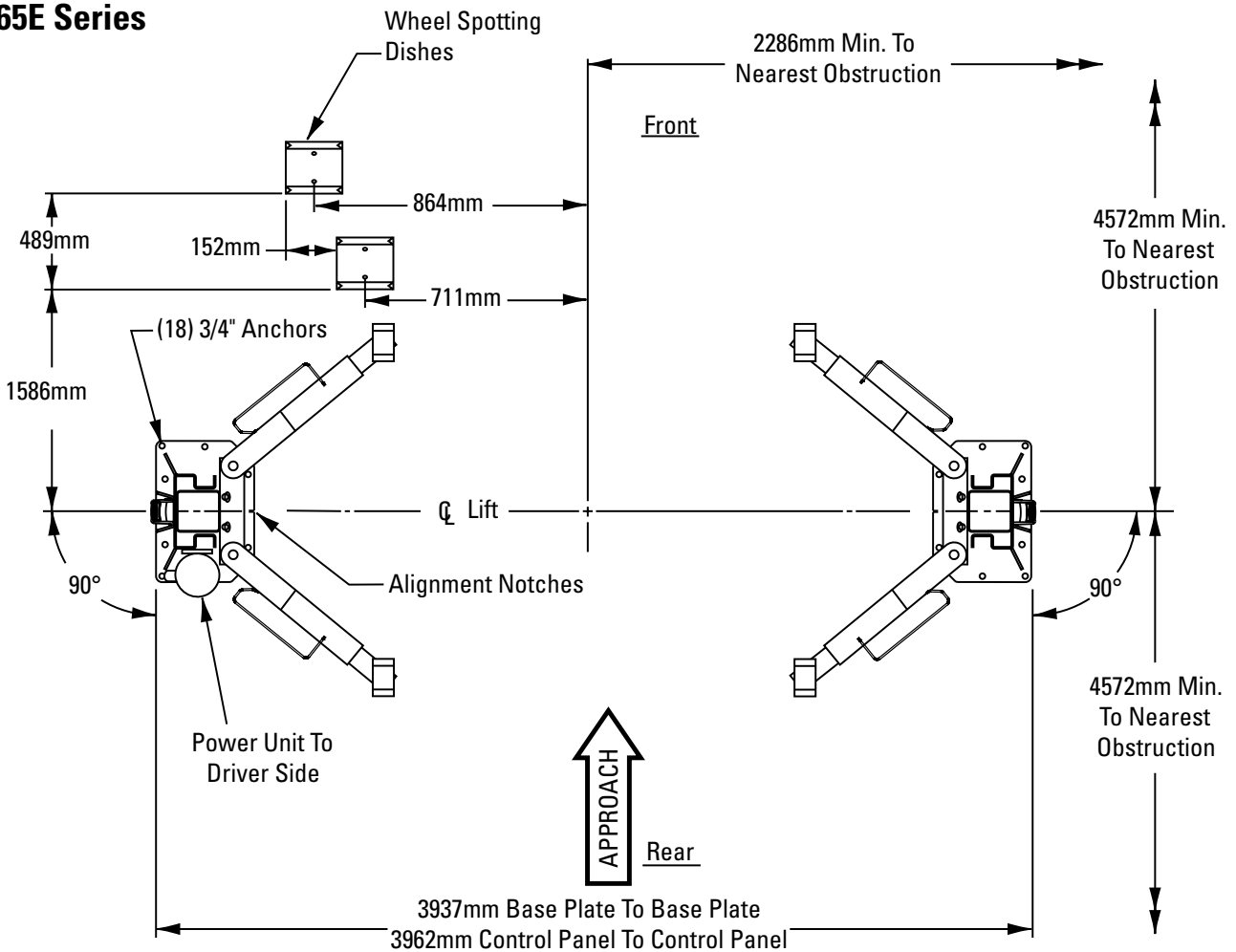


Fig. 1

# SP065E Series



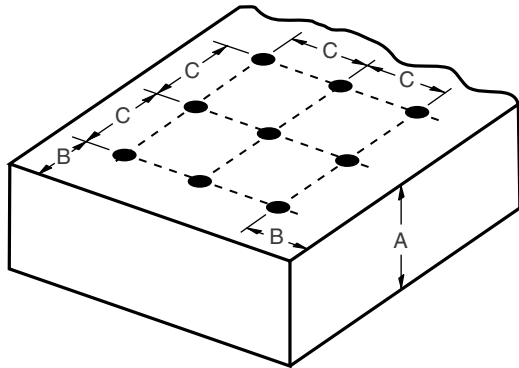
- Lift Location:** Use architects plan when available to locate lift. Fig. 1 shows dimensions of a typical bay layout.
- Lift Height:** See Fig. 4 for overall lift height of each specific lift model. Add 25.4mm min. to overall height to lowest obstruction.

**⚠️ WARNING** DO NOT install this lift in a pit or depression due to fire or explosion risks.

- Lift Setting:** Using a block and tackle (or similar device that increases mechanical advantage), stand the columns up. Position columns in bay using dimensions shown in Fig.1. Place column with power unit mounting bracket on vehicle passenger side of lift. Both column base plate backs must be square on center line of lift. Notches are cut into each base plate to indicate center line of lift.

Use appropriate equipment to raise carriage to first latch position. Be sure locking latch is securely engaged.

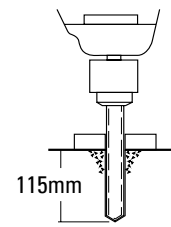
- A) Concrete Thickness & Hole Depth (220mm)
- B) Edge Distance (120mm)
- C) Hole Spacing (165mm)



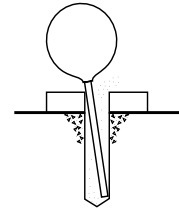
- Concrete and Anchoring:** Concrete shall have a compression strength of at least 20.68 N/mm<sup>2</sup> and a minimum thickness of 108mm in order to achieve a minimum anchor embedment of 83mm. When using the standard supplied 3/4" x 5-1/2" lg. anchors, if the top of the anchor exceeds 57mm above the floor grade, you **DO NOT** have enough embedment.

Drill (18) 19mm dia., Fig. 2 holes in concrete floor using holes in column base plate as a guide. See diagrams for hole depth, hole spacing, and edge distance requirements.

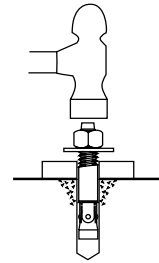
**⚠️ CAUTION** DO NOT install on asphalt or other similar unstable surfaces. Columns are supported only by anchors in floor.



Drill holes using 19mm carbide tipped masonry drill bit per ANSI standard B94.12.1977

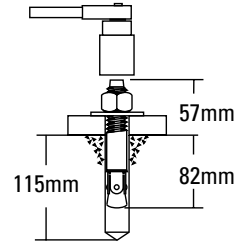


Clean hole.



Run nut down just below impact section of bolt. Drive anchor into hole until nut and washer contact base.

**Fig. 2**

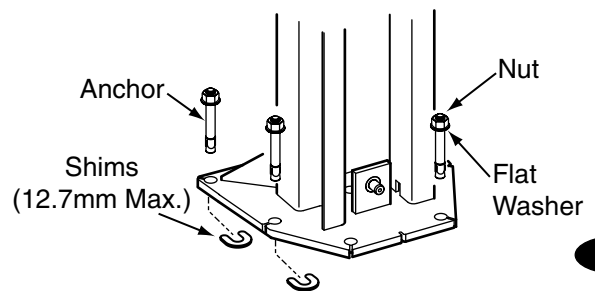


Tighten nut with Torque wrench to 203.4Nm.

**Installation torque of 203.4Nm. is required for all anchor bolts.**

**IMPORTANT** Using the horse shoe shims provided, shim each column base until each column is plumb, Fig. 3. If one column has to be elevated to match the plane of the other column, full size base shim plates should be used (Reference Shim Kit). Recheck columns for plumb. Tighten anchor bolts to an installation torque of 203.4 Nm. Shim thickness **MUST NOT** exceed 13mm when using the 140mm long anchors provided with the lift.

If anchors do not tighten to 203.4 Nm. installation torque, replace concrete under each column base with a 1219mm x 1219mm x 152mm thick 20.68 Nmm<sup>2</sup> minimum concrete pad keyed under and flush with the top of existing floor. Let concrete cure before installing lifts and anchors.



**Fig. 3**

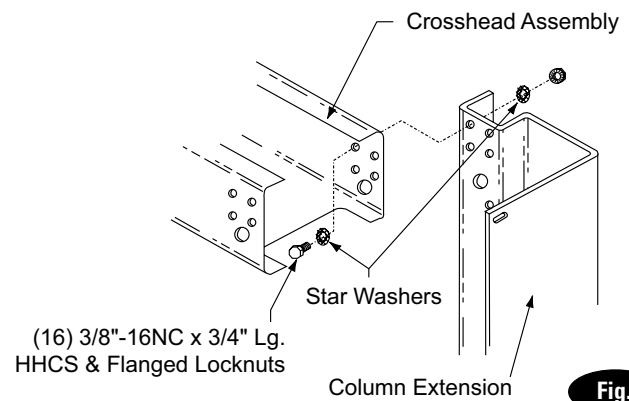
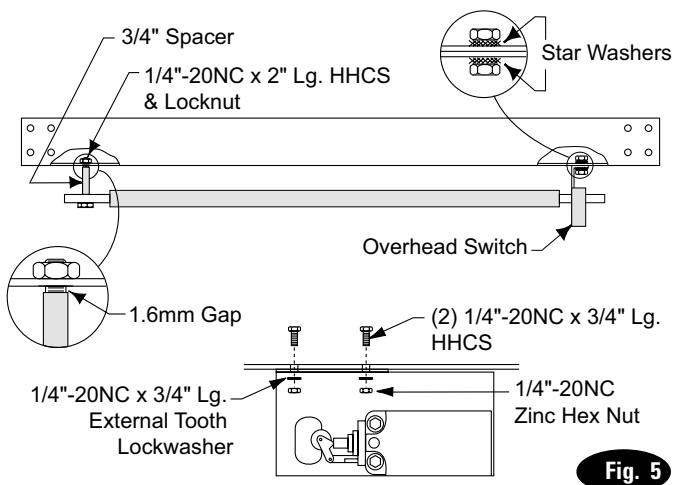
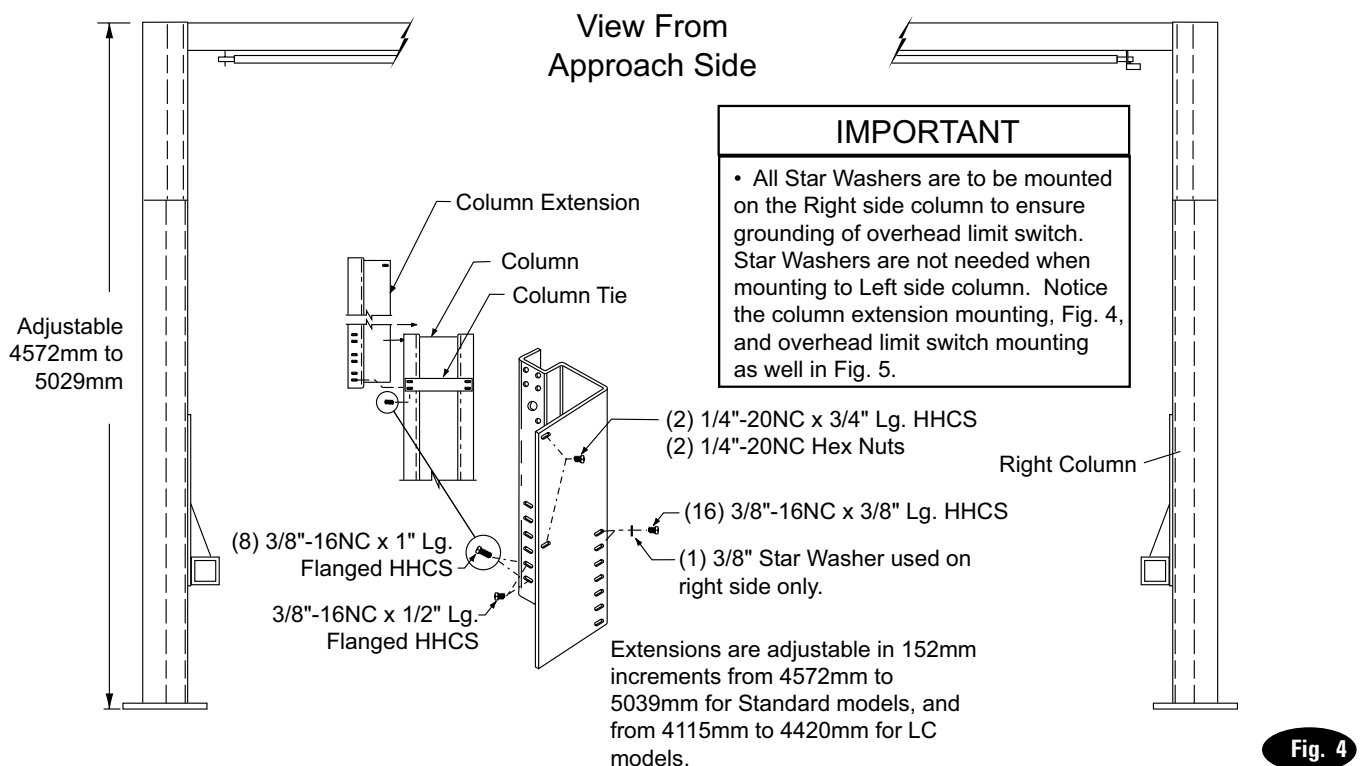
**NOTE:** If more than 2 horse shoe shims are used at any of the column anchor bolts, pack non-shrink grout under the unsupported area of the column base. Insure shims are held tightly between the baseplate and floor after torquing anchors.

5. Install column extensions to columns using (16) 3/8"-16NC x 3/8" lg. Flanged HHCS, Fig. 4, and Column Ties using (8) 3/8"-16NC x 1" Flanged HHCS, also Fig. 4. Adjust column extensions plumb as required.

6. Mount switch assembly towards power unit column as shown, Fig. 5, using (2) 1/4"-20NC x 3/4" lg. HHCS, nuts and Star Washers. Insert 2" Hex bolt through pivot hole in end of switch bar. Insert opposite end (weighted end) of bar through slot in switch mounting bracket. Then secure Hex bolt and switchbar to overhead as shown, using 3/4" spacer and lock nut. Tighten Hex bolt leaving 1.6mm gap between the spacer and the crosshead assembly.

7. Install crosshead assembly to column extensions with (16) 3/8"-16NC x 3/4" lg. HHCS, Flanged Locknuts and Star Washers, Fig. 6.

**Attention: For M series lifts proceed to page 7 Step 8.**



**8. Unité d'alimentation de la série E:** Attach vibration pads and locknuts to bolts per Fig. 7. Enfoncer les 4 vis en acier au carbone à tête hex. 5/16"-18NC x 1 - 1/2" à travers les trous de l'unité d'alimentation, fig. 7. Raccorder les coussinets anti-vibration et les contre-écrous aux boulons comme l'indique la fig. 7. Installer et serrer à la main le raccord en T sur la pompe jusqu'à ce que le joint torique ait une assise correcte, fig. 8. Continuer de serrer le contre-écrou à 10-15 pieds-livres ou jusqu'à ce que l'écrou et la rondelle se trouvent plaqués contre le distributeur de pompe.

**Remarque:** Il se peut qu'il soit encore possible de faire pivoter le raccord en T. Ceci est admissible à moins qu'il n'y ait une infiltration sur le joint torique. Si c'est le cas, serrer légèrement le contre-écrou.

**CAUTION** Si vous serrez le contre-écrou trop fort, vous risquez de déchirer le joint torique ou de tordre le filetage de la sortie du distributeur de pompe.

Accrocher l'unité d'alimentation sur l'extension de colonne côté conducteur, fig. 1. Enfoncer les deux boulons du bas dans l'étrier de l'unité en les faisant passer à travers l'extension de colonne. Visser 2 contre-écrous à bride 5/16"-18NC sur les boulons. Serrer les quatre boulons sur l'étrier de l'unité d'alimentation en vérifiant qu'il est fixé à la colonne, fig. 8a. Accrocher l'unité d'alimentation sur l'extension de colonne côté conducteur, fig. 1. Enfoncer les deux boulons du bas dans l'étrier de l'unité en les faisant passer à travers l'extension de colonne. Visser 2 contre-écrous à bride 5/16"-18NC sur les boulons. Serrer les quatre boulons sur l'étrier de l'unité d'alimentation en vérifiant qu'il est fixé à la colonne, fig. 8a.

Attach (2) 5/16"-18NC Flanged Locknuts To Top Bolts Just Far Enough To Allow You To Hang The Power unit On The Column Safely

Put Bolts Through Bottom Of Power Unit Bracket And Push Vibration Pads Onto The Bolts

Keep Bottom Vibration Pads Flush With The Ends Of The Bolts This Will Aid In The Installation Of The Power Unit To The Column Extension

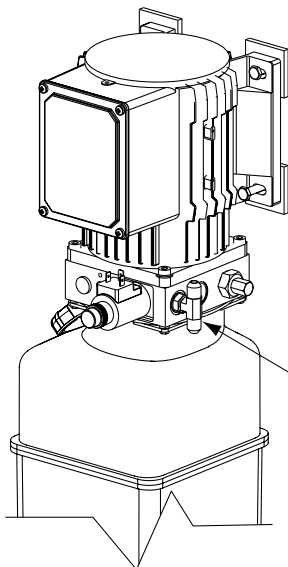
Do Not Put Bottom Flanged Lock Nuts On At This Time These Will Have To Be Attached Through The Column Extension

Fill Breather Cap

5/16"-18NC x 1-1/2" HHCS

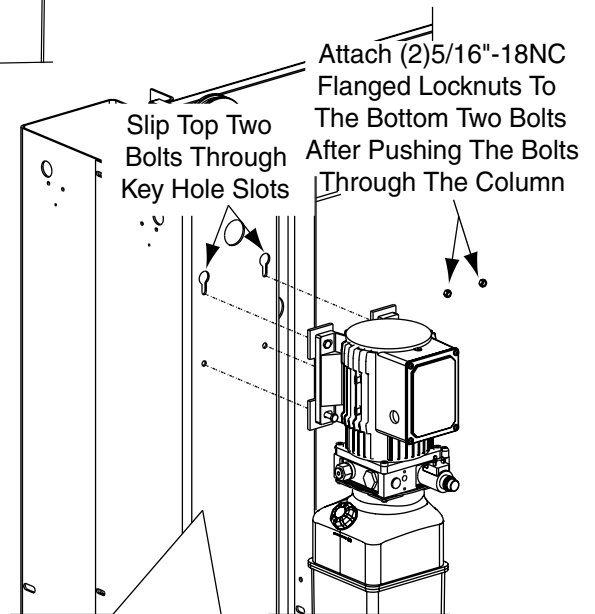
Vibration Pad

Fig. 7



Hand Tighten Tee Then Tighten Hex Locknut 10-15 ft-lbs.

Fig. 8



Slip Top Two Bolts Through Key Hole Slots

Attach (2) 5/16"-18NC Flanged Locknuts To The Bottom Two Bolts After Pushing The Bolts Through The Column

Fig. 8a

**9. E Series Hoses:** Before routing hoses insert rubber grommet in column, Fig. 10. Clean adapters and hose. Inspect all threads for damage and hose ends to be sure they are crimped, Fig. 10a.

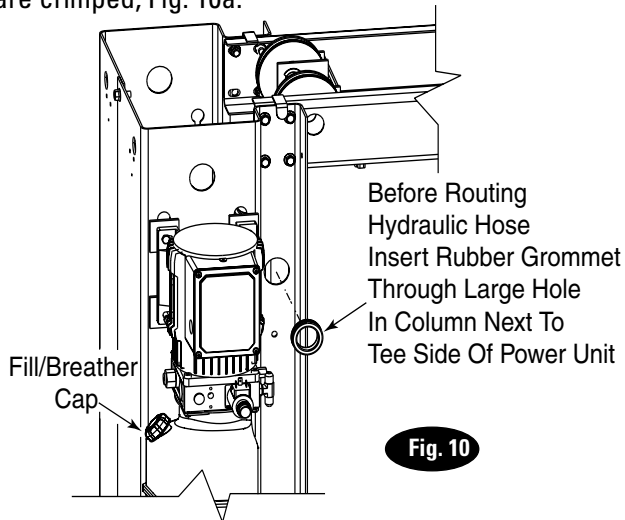


Fig. 10

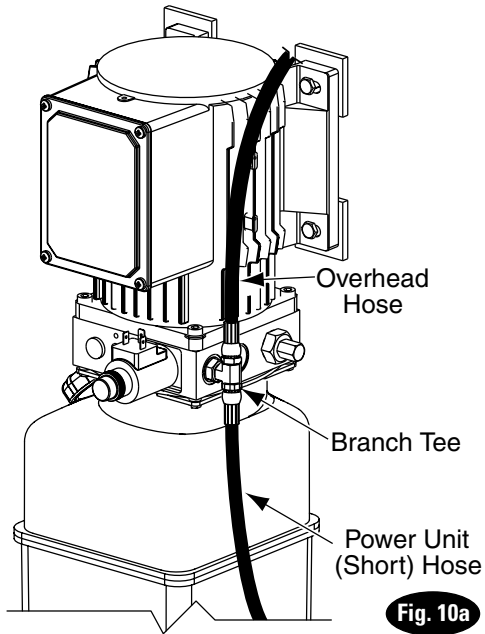


Fig. 10a

**Flared Fittings Tightening Procedure**

1. Screw the fittings together finger tight. Then, using the proper size wrench, rotate the fitting 2-1/2 hex flats (1/3 of a revolution).
2. Back the fitting off one full turn.
3. Again tighten the fittings finger tight; then using a wrench, rotate the fitting 2-1/2 hex flats (1/3 revolution). This will complete the tightening procedure and develop a pressure tight seal.

**Adapter & Hose Installation**

1. Install Pc. (2) with hose clamps, on power unit column side connecting it to the cylinder (1) first.
2. Install Pc. (3) with hose clamps starting at left column cylinder (5) and working toward the right column. All excess hose should be at bends & inside overhead assembly.
3. Install Pc. (4) into power unit.
4. Connect Pc. (2) & Pc. (3) to Tee (4).

**NOTE:** Route Power Unit hose inside columns using slots provided at column base, Fig. 10b. Route Overhead Hose in column channel on outside of column, Fig. 10b. Overhead hose goes through holes beside sheaves in the overhead weldment, Fig. 10b.

**Oil Filling:** Use Dexron III ATF, or Hydraulic Fluid that meets ISO 32 specifications. Remove fill-breather cap, Fig. 10. Add fluid until it reaches fill line on tank. System capacity is (14) quarts. Replace fill-breather cap.

**Attention: For E series lifts proceed to page 8 Step 10.**

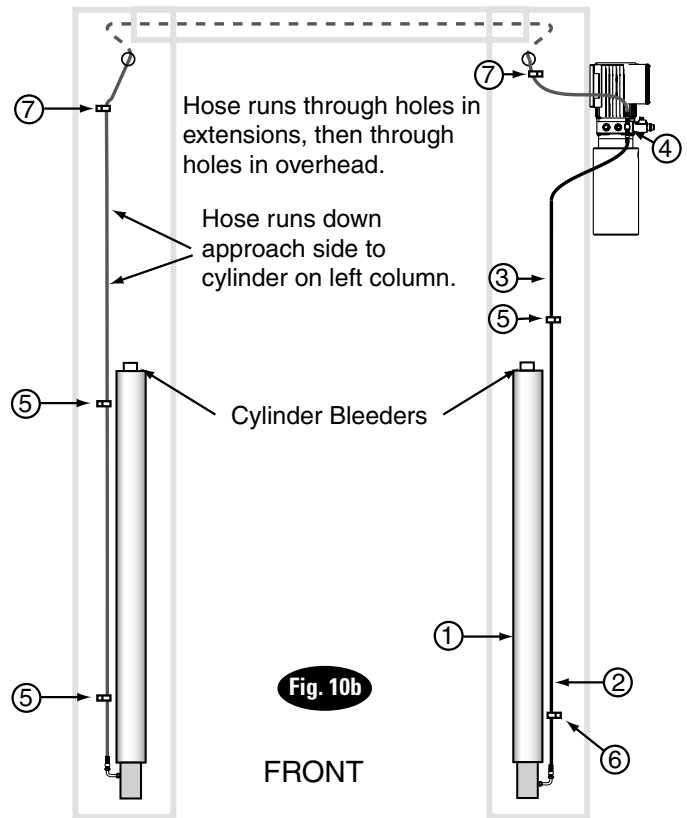
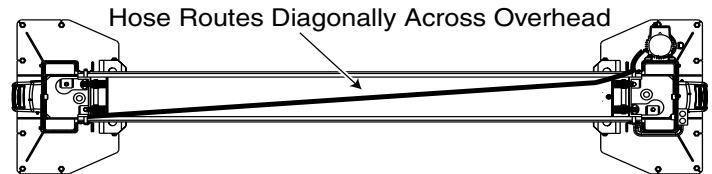


Fig. 10b

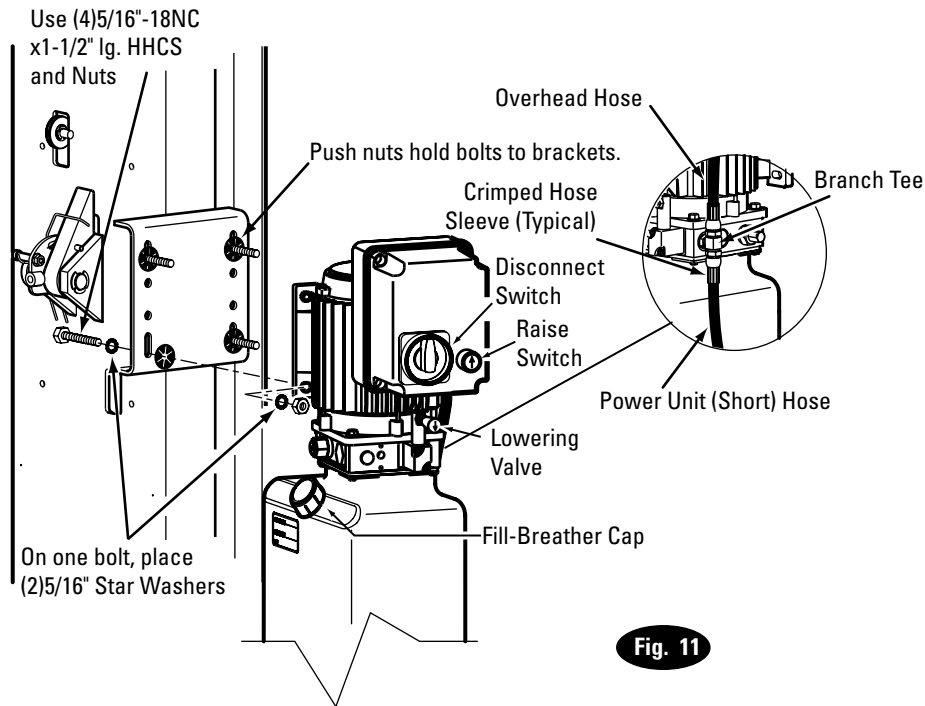
ITEM	QTY.	DESCRIPTION
1	2	Hydraulic Cylinder
2	1	Power Unit Hose
3	1	Overhead Hose
4	1	Branch Tee
5	3	Hose Clips(5/8")
5	3	5/16"-18NC x 3/8" lg. PHMS
6	1	Hose Clips(1/2")
6	1	5/16"-18NC x 3/8" lg. PHMS
7	2	Hose Clips(5/8")
7	2	5/16"-18NC x 1/2" lg. PHMS
7	2	5/16"-18NC Nut

8. **M Series Power Unit:** First install (1) Star Washer onto one of the (4) 5/16" 18NC x 1-1/2" bolts. **This is very important for grounding.** Put (4) 5/16" 18NC x 1-1/2" lg. bolts thru holes in power unit bracket using push-nuts to hold in place. With the motor being the heaviest part of the unit, two people lift the unit, each with one hand supporting the motor. Position the unit on the bolts with one person supporting the power unit while the other installs lock washers and nuts. Install and tighten Hydraulic Hose Adapter to pump. Then install and tighten Tee, and connect supply hoses to Tee, Fig. 11.

9. **M Series Hoses:** Clean adapters and hose. Inspect all threads for damage and hose ends to be sure they are crimped, Fig. 11.

#### Flared Fittings Tightening Procedure

1. Screw the fittings together finger tight. Then, using the proper size wrench, rotate the fitting 2-1/2 hex flats (1/3 of a revolution).
2. Back the fitting off one full turn.
3. Again tighten the fittings finger tight; then using a wrench, rotate the fitting 2-1/2 hex flats (1/3 revolution). This will complete the tightening procedure and develop a pressure tight seal.



## M Series Adapter & Hose Installation

1. Install item (2) with hose clamps, on power unit column side connecting it to the cylinder (1) first.
2. Install item (3) with hose clamps starting at left column cylinder (5) and working toward the right column. All excess hose should be at bends & inside overhead assembly.
3. Install item (4) into power unit.
4. Connect item (2) & item (3) to Tee (4).

**NOTE:** Route Power Unit hose inside columns using slots provided at column base, Fig. 12. Route Overhead Hose in column channel on outside of column, Fig. 12. Overhead hose goes over top end of overhead assembly, Fig. 12 and Fig. 12a.

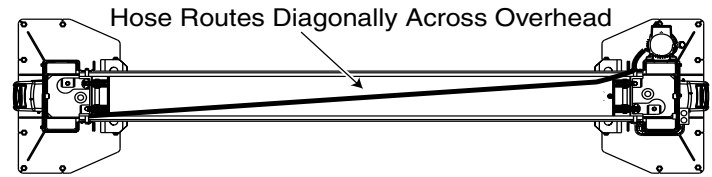


Abb. 12a

### HOSE ROUTING FOR SPO65M SERIES

ITEM	QTY.	DESCRIPTION
1	2	Hydraulic Cylinder
2	1	Power Unit Hose
3	1	Overhead Hose
4	1	Branch Tee
5	6	Hose Clips
6	6	3/8"-16NC x 3/4" Carriage Bolts
6	6	3/8"-16NC Flanged Locknuts
6	4	Hose Clips
4	4	3/8"-16NC x 3/4" HHCS
4	4	3/8"-16NC Flanged Locknuts
7	2	Mechanical Lift Hole Plug

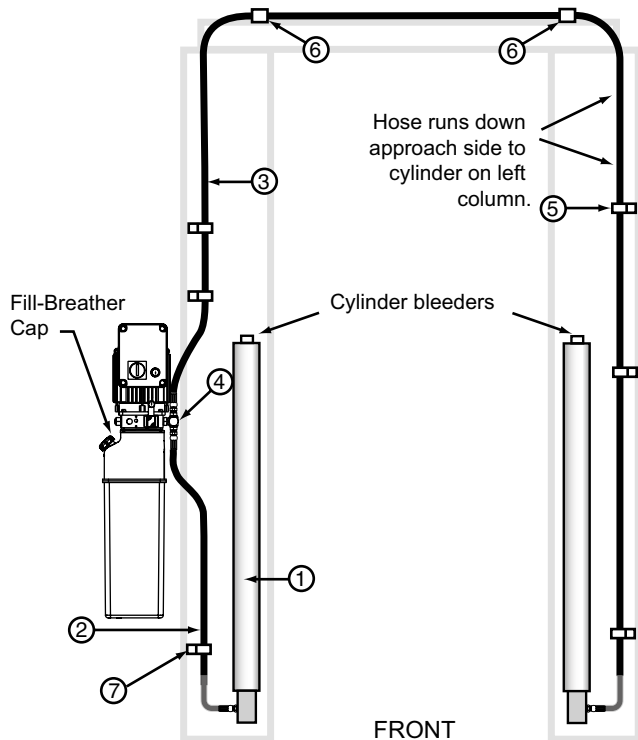


Abb. 12

**10. Equalizer Cables:** Fig. 13 describes general cable arrangements. It is easier to tie-off lower studs first.

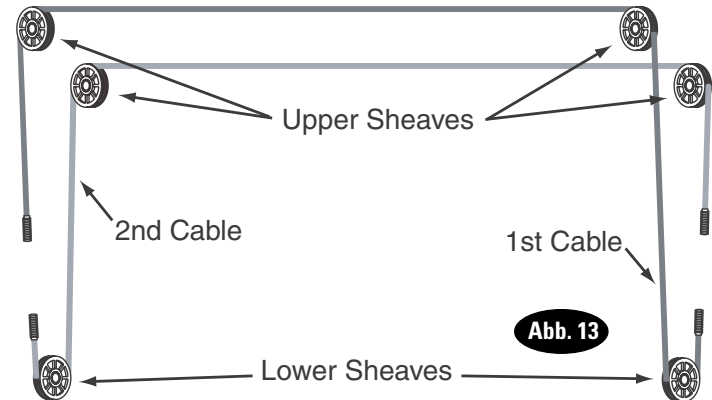
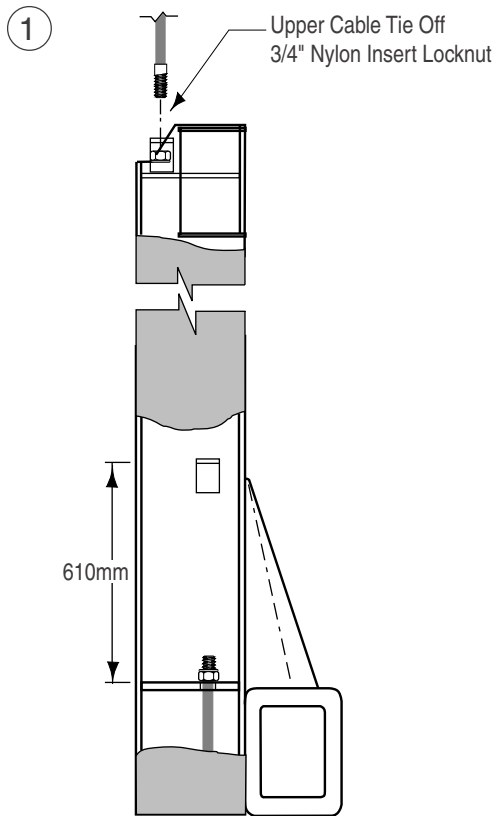


Abb. 13

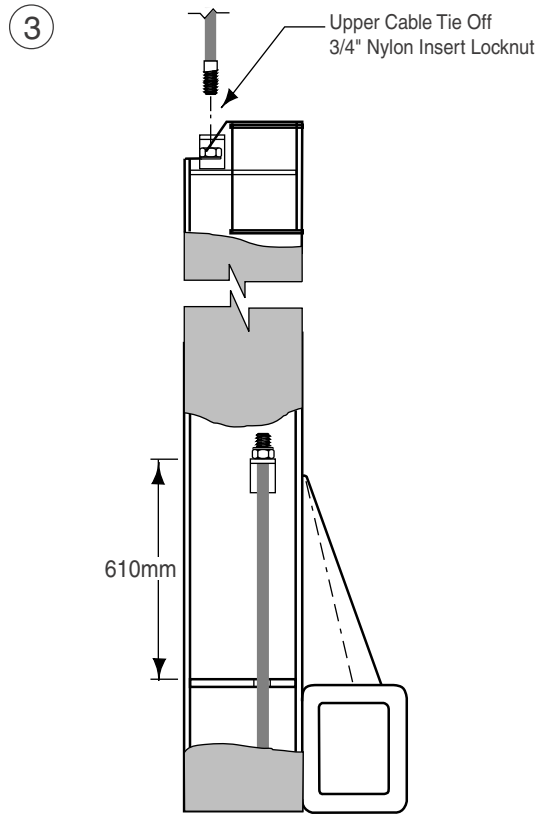
- Run cable stud up through the lower tie-off plate, and/or bracket(s), and/or spacer(s) depending on the lift model, Fig. 14.
- Push cable up until stud is above top of carriage Fig. 10.
- Run nylon insert locknut onto studs so that 12mm extends out from locknut Fig. 14.
- Pull cables back down through carriage Fig. 14.
- Run cable overhead and tie-off top studs and torque to about 11.3J., see Fig. 13 & Fig. 14.

**Attention: For E series lifts proceed to page 12 Step 11.**

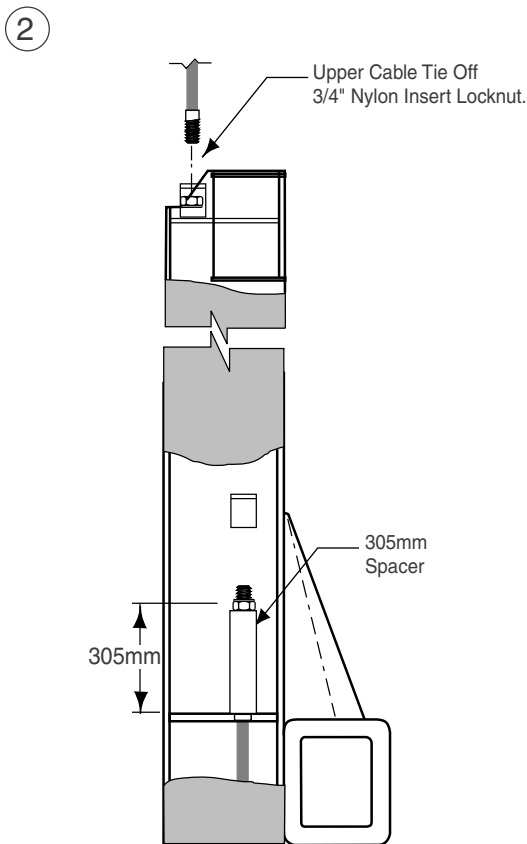




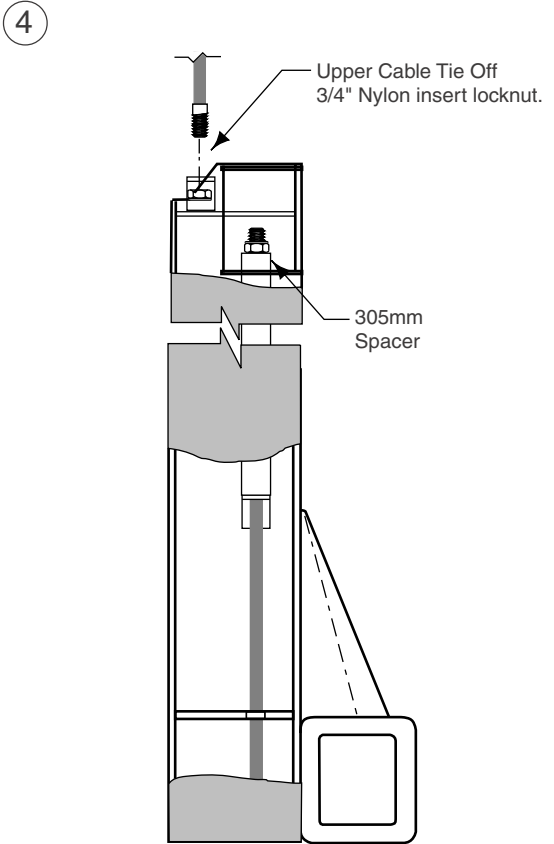
For 5029mm height with 11,989mm long cable or for 4420mm height with 10,770mm long cable, both use pattern one.



For 4724mm height lift with 11,989mm cable, or 4115mm height lift with 10,770mm long cable. Use pattern 3.



For 4877mm height lift with 11,989mm cable or for 4267mm height lift with 10,770mm long cable, both use pattern two. Has 305mm spacer provided.



For 4572mm height carriages use pattern four with 11,989mm cable. Has 305mm spacer provided.

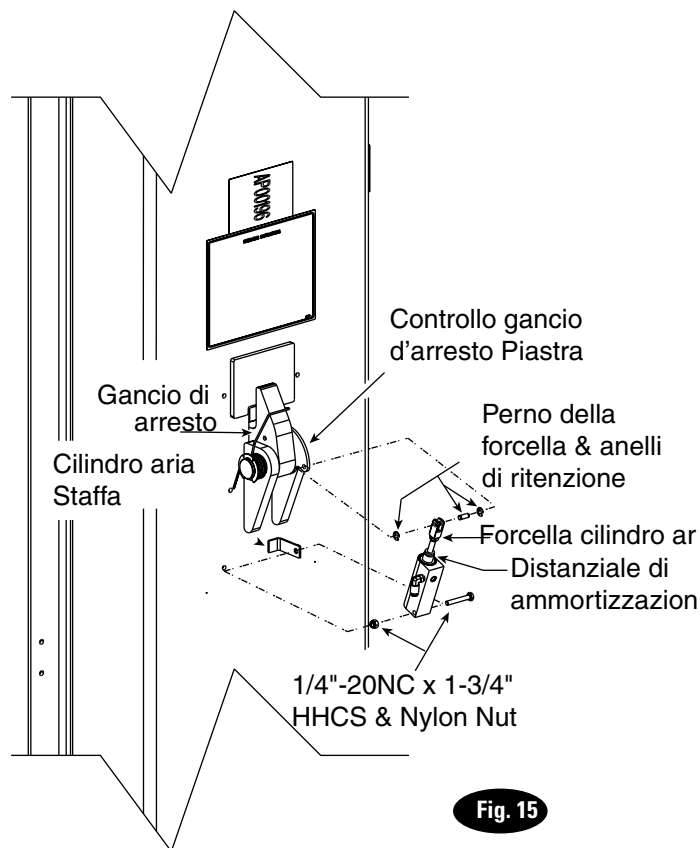
### 11. For M Series Locking Latch & Air Cylinders:

- A) To install cylinder, first slip dampening spacer over rod with rod in retracted position, Fig. 15.
- B) Put locknut on threaded shaft and run it down to the dampening spacer.
- C) Let rod extend and thread locknut down 1-1/2 more turns.
- D) Screw Bracket Clevis onto shaft, position, and tighten locknut securely, Fig. 15.
- E) Attach air cylinder clevis to latch control plate with clevis pin and retaining rings, Fig. 15. Attach bottom of air cylinder to air cylinder bracket with 1/4" x 1-3/4" HHCS and nylon nut, Fig. 15. Repeat procedure for other locking latch.
- F) Mount lowering switch and bracket to column using (2) 5/16"-18NC x 3/8" lg. PHMS, Fig. 15a.
- G) Install air lines from main air supply (with filter) to lowering switch. Install air line from lowering switch to union tee then to the right column air cylinder.
- H) Install air line from union tee to left column air cylinder. Figs. 15b and 16.

**Note:** Cut provided tubing with sharp blade to length as required. Tubing must be cut square with no burrs. To assemble air line tubing into fitting, use firm, manual pressure to push tubing into fitting until it bottoms, see below. If removal of the air line tubing from the fitting is ever required, hold Push Sleeve in (against fitting) and at the same time, pull out on tubing.

#### Locking Latch Engagement Test:

- A) Raise carriages past the first latch position and then lower onto latches.
- B) Check that the latches have fully engaged when the release switch is not depressed.
- C) Raise carriages fully off latches. Now depress release switch and check that the latches have fully disengaged.
- D) Check for air leaks, make necessary adjustments or repairs if required.
- E) Install latch covers with 5/16"-18NC x 3/8" lg. BHCS, Fig. 17.



**Fig. 15**

**Attention: For M series lifts proceed to page 24 Step 12.**

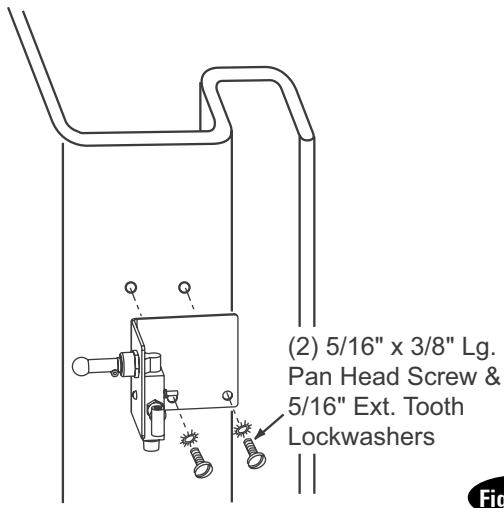


Fig. 15a

**Note:** Absence of air filter will void the warranty on all pneumatic components

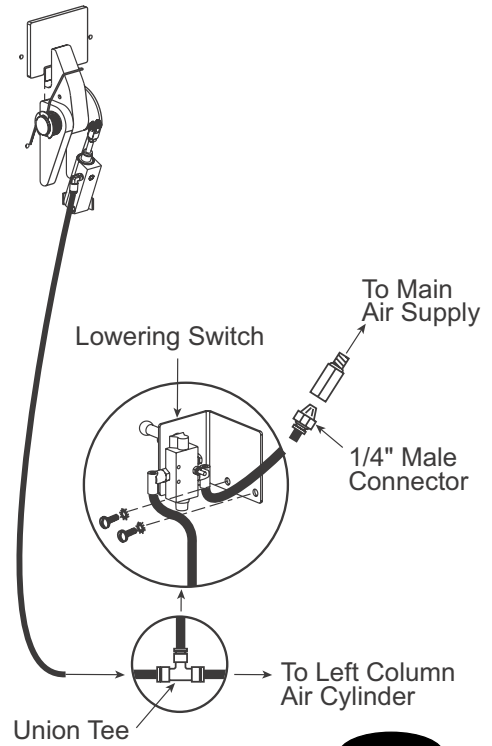


Fig. 15b

\* Do Not Route Switch Cord Thru This Hole

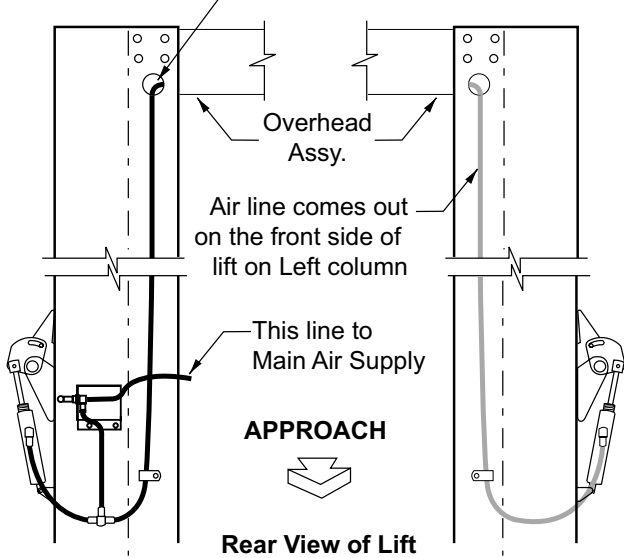


Fig. 16

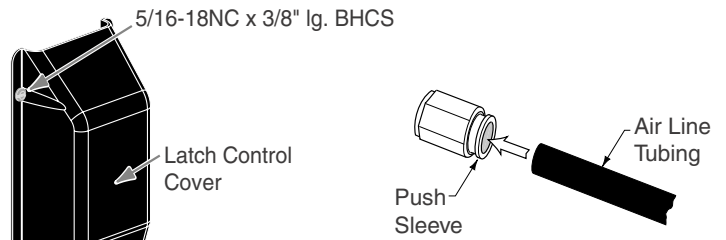


Fig. 17

### 11. For E Series Locking Latch & Air Cylinders:

- A) To install cylinder, first slip dampening spacer over rod with rod in retracted position, Fig. 18.
- B) Put locknut on threaded shaft and run it down to the dampening spacer.
- C) Let rod extend and thread locknut down 1-1/2 more turns.
- D) Screw Bracket Clevis onto shaft, position, and tighten locknut securely, Fig. 18.
- E) Attach air cylinder clevis to latch control plate with clevis pin and retaining rings, Fig. 12. Attach bottom of air cylinder to air cylinder bracket with 1/4" x 1-3/4" HHCS and nylon nut, Fig. 18. Repeat procedure for other locking latch.

### 12. Installing Master Control Panel & Tool Holder:

- Remove access panel from the master control panel, Fig. 19.
- Install (2) 5/16"-18NC x 3/8" PHMS screws in holes on each side of the locking latch (power unit side) leaving approximately 3mm exposed to hold the panel. Hang the master control panel over locking latch to column on the 5/16"-18NC x 3/8" PHMS screws and pull the locking latch solenoid wire through the panel, Fig. 19. Plug locking latch solenoid into master control panel.
- Install (1) 5/16"-18NC x 3/8" PHMS in bottom of master control panel. Tighten down all (3) screws. Do not install access panel back into control panel at this time. It will be reinstalled in a later step.

12a. Install Master Cable Motor Cable to Master panel connections. Fig. 19.

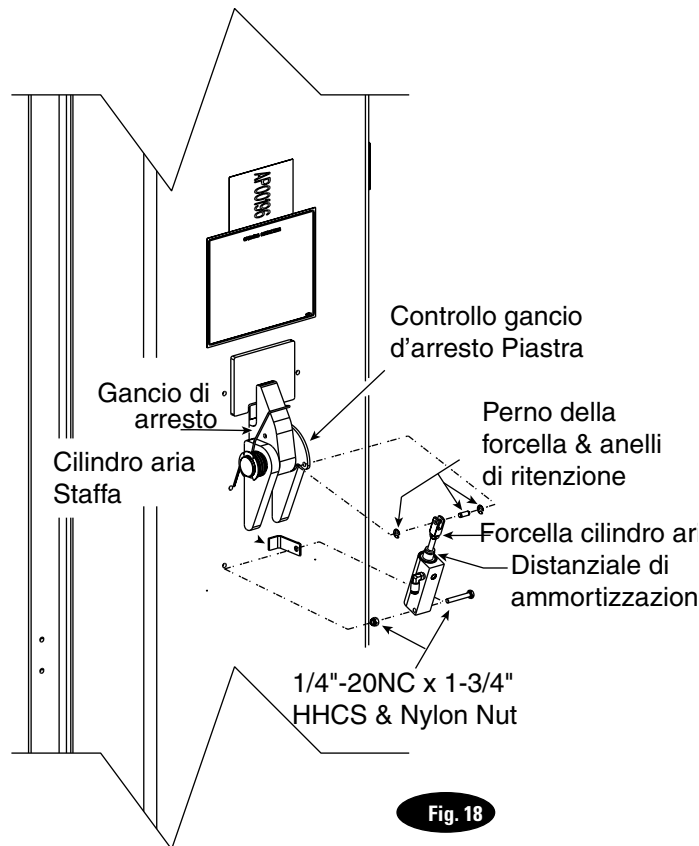
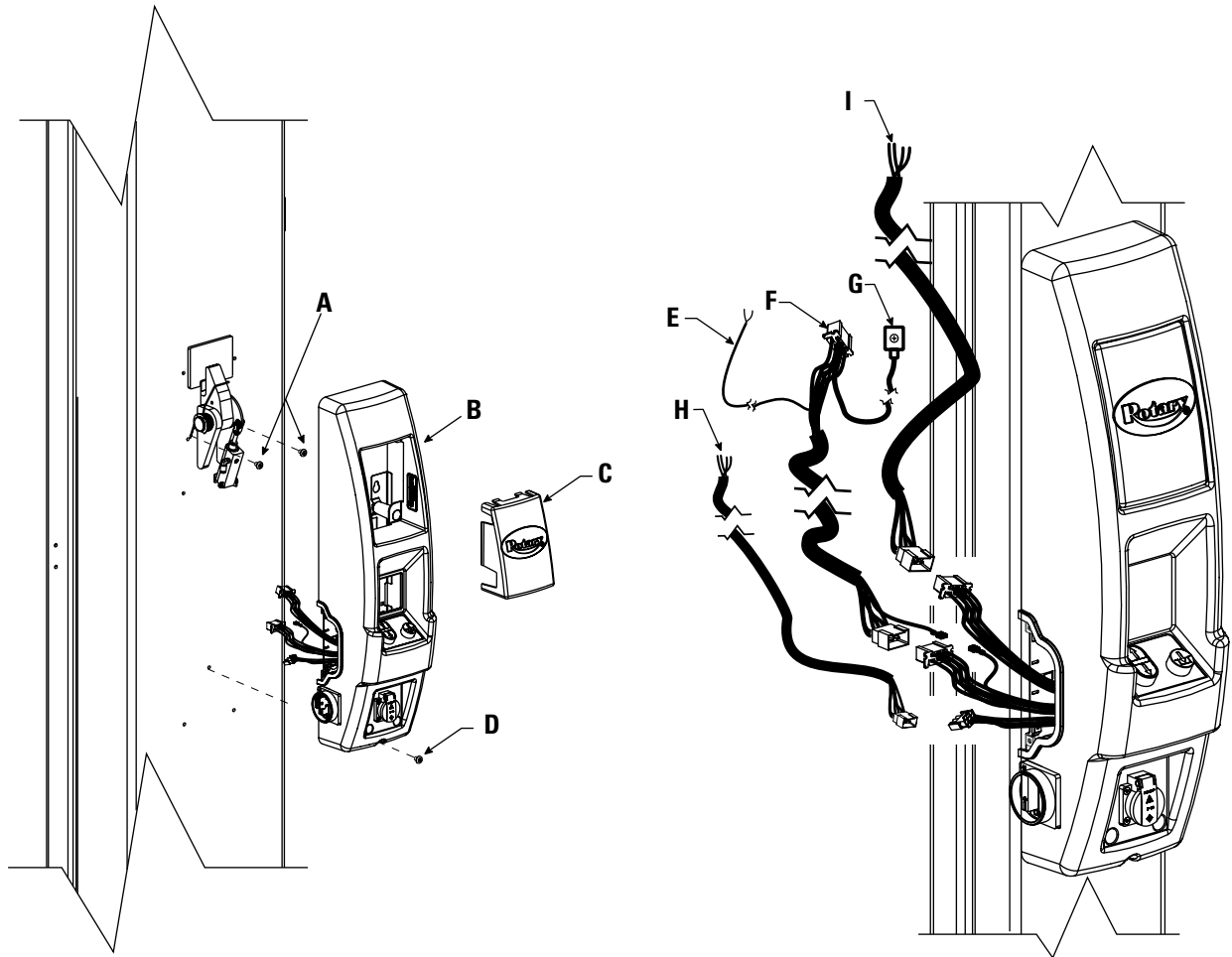


Fig. 18



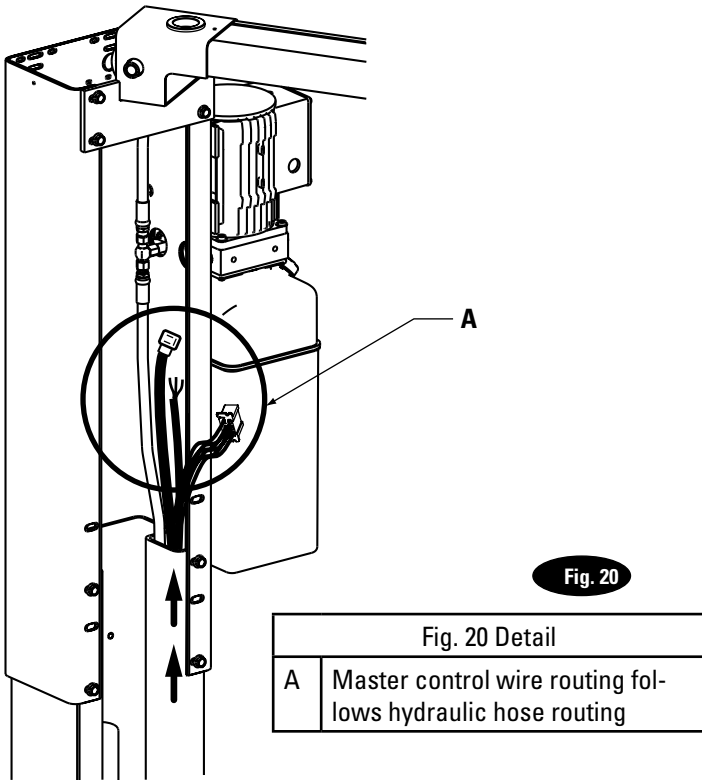
**Fig. 19**

Fig. 19 Detail	
A	5/16"-18NCx3/8" PHMS, Leave these two screws exposed out of the column approximately 3mm.
B	<b>IMPORTANT</b> Master control panel always mounts on the power unit side.
C	Access Panel
D	5/16"-18NCx3/8" PHMS, Through the control panel.
E	Overhead Switch Cable
F	Master Cable

Fig. 19 Detail	
G	Lowering Valve Cable
H	Motor Cable
I	Power Harness Cable

### 12-1. Routing Motor and Master Cables:

From the master control panel route cables up through column along the hose routing, Fig. 20.



- A) Locate the overhead switch cable at the master cable connector. Feed the overhead switch cable through the strain relief and into the overhead switch box, Fig. 22.
- B) Attach lowering valve cable to lowering valve and tighten screw on top, Fig. 22.
- C) Run the motor cable through strain relief in the motor junction box. Motor wiring and wire diagrams are detailed in, Fig. 25.

### 12-2. Installing Slave Control Panel & Tool Holder:

Remove access panel from the slave control panel, Fig. 21. Place (2) 5/16"-18NC x 3/8" PHMS screws in holes on each side of the locking latch leaving approximately 3mm exposed to hold the panel. Hang the slave control panel over locking latch to column on the 5/16"-18NC x 3/8" PHMS screws and pull the locking latch solenoid wire through the panel, Fig. 21. Install (1) 5/16"-18NC x 3/8" PHMS in bottom of slave control panel. Do not install access panel back into control panel at this time. It will be reinstalled in a later step.

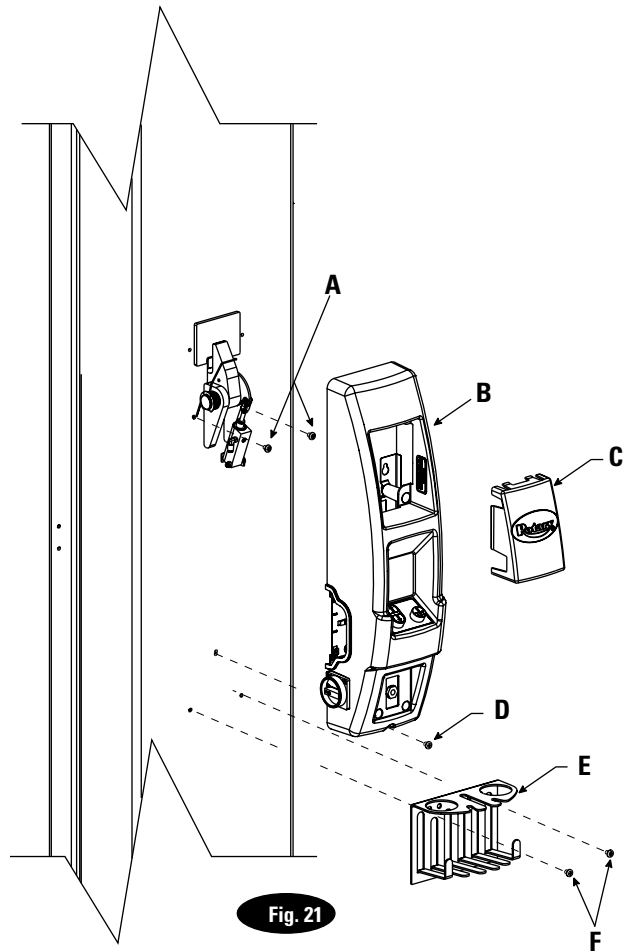
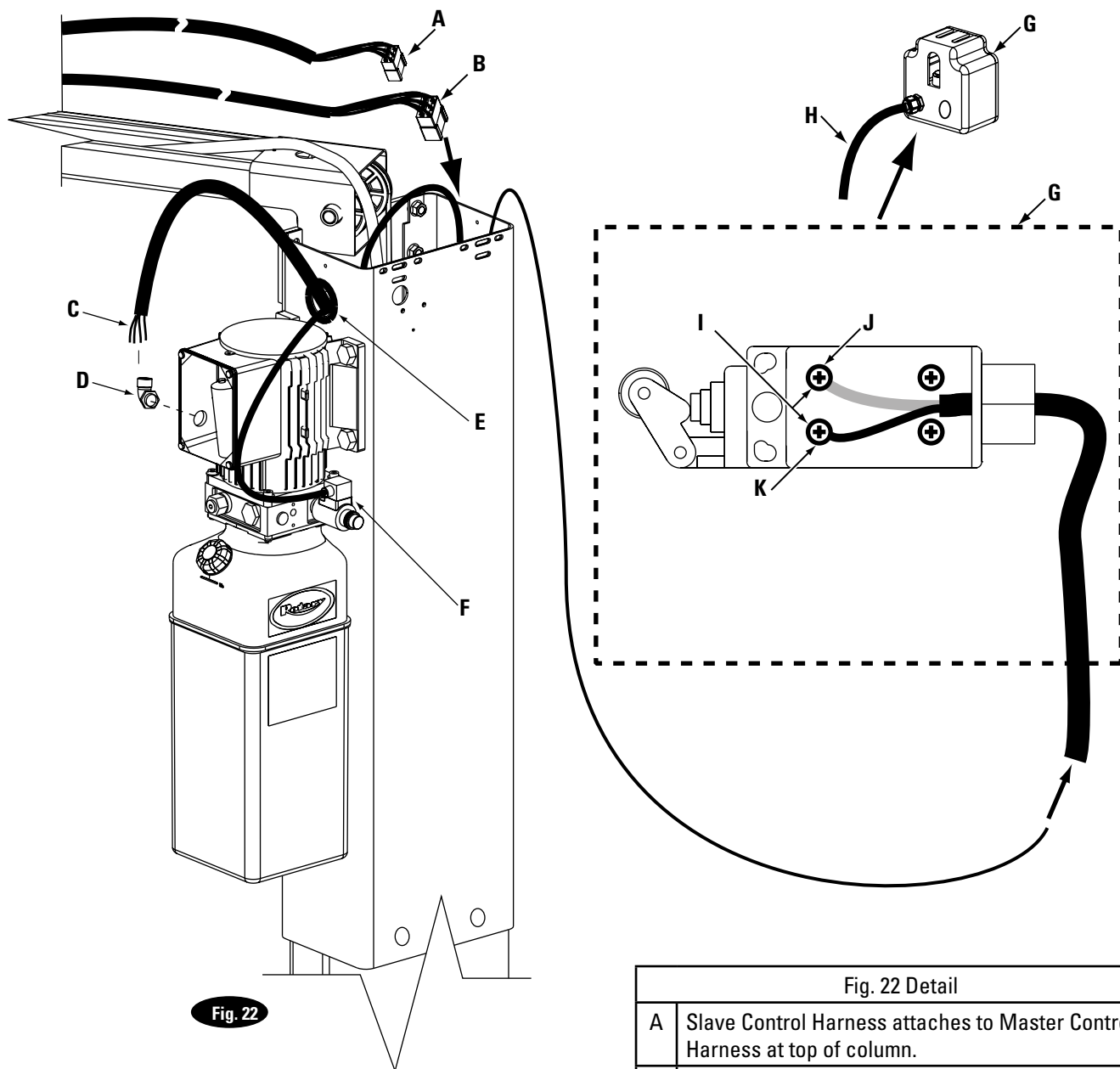


Fig. 21 Detail	
A	5/16"-18NCx3/8" PHMS, Leave these two screws exposed out of the column approximately 3mm.
B	<b>IMPORTANT</b> Slave control panel always mounts on opposite column of the power unit.
C	Access Panel
D	5/16"-18NCx3/8" PHMS, Through the control panel.
E	Pull connector through panel



**Fig. 22**

**Fig. 22 Detail**

Fig. 22 Detail	
A	Slave Control Harness attaches to Master Control Harness at top of column.
B	Power harness or extension for power harness follows hydraulic hose back to slave control panel.
C	4 wire from master control panel goes through strain relief into junction box on powerunit motor.
D	Strain Relief
E	Grommet Note: Secure all cables coming up from master control panel to grommet hole with a wire tie when hook-up is complete.
F	Plug in lowering valve cord and tighten screw on top to lock in place.
G	Overhead Limit Switch
H	From master cable connector
I	N.O. Contacts
J	White Wire
K	Black Wire

### 12-3. Slave Cable & Disconnect Harness Routing:

- A) Remove cover panel from slave control side, Fig. 23 disconnecting the pushbutton cable from slave harness. Do not unscrew the ground connection. Unplug airline from back of Slave Control Panel bulkhead, Fig. 23.
- B) Wire the disconnect harness into the bottom of the slave side disconnect as shown in Fig. 23a. Facility power will be wired into top of the slave side disconnect.
- C) Run slave cable up through the column along hose routing.
- D) Secure cable to structure with wire ties and away from equalization cables.
- E) Connect the master cable to the slave cable near the top of the master column. If extension cables are needed connect them between the master and slave cables.
- F) Run the disconnect harness down the master column and plug into master control and add extensions if necessary.
- G) Do not attach the slave control panel to the back plate until the gasket has been installed in Step 12-6.

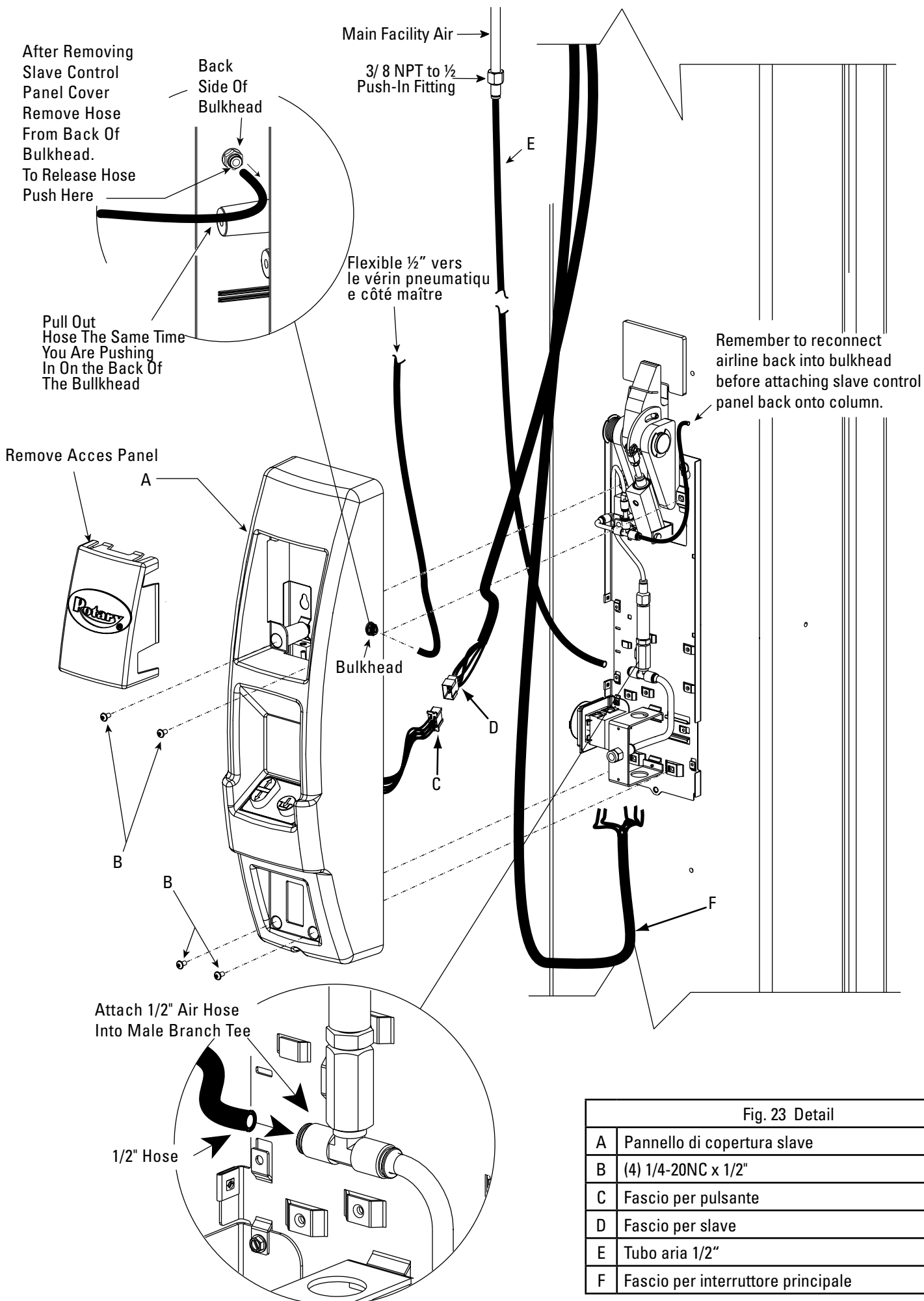
### 12-4. Air Connections:

- A.) Attach 1/2" airline into male branch tee, Fig. 23. Make sure airline is square not cut at a taper.
- B.) Route 1/2" airline up column channel to facility air. Connect with 3/8" NPT fitting provided.
- C.) Insert 1/2" airline into Slave Control Panel bulkhead (outside of bulkhead), Fig. 23. and route hose up column thru hole in top of the column extension trough.
- D.) Airline will follow the hydraulic hose up slave side column, across the overhead, down the power unit column through the wire chase opening on the master side enclosure and plug into the air cylinder connection.
- E.) Re-attach Slave Control Panel Cover making sure to plug airline into the back of the bulkhead. Plug in push buttons and air cylinder connections, Fig. 23.

**IMPORTANT** Be sure all cables do not become pinched between the backplate and the control panel where it screws in.

Note: Before cutting the airline to insert into the Master Control Panel bulkhead go back to the Slave Control Panel Column and wire tie airline to the column. Also make sure that the airline is not making contact with the pulleys and cables in the overhead assembly. Use wire ties to keep the airline against the hydraulic hose all the way to the Master Control Panel.





**Fig. 23**

Fig. 23 Detail	
A	Pannello di copertura slave
B	(4) 1/4-20NC x 1/2"
C	Fascio per pulsante
D	Fascio per slave
E	Tubo aria 1/2"
F	Fascio per interruttore principale

Fig. 23a Three Phase Detail

A	Facility power connects into the top of the disconnect.
B	Power harness to Master Control panel connects into the bottom of the disconnect.
C	Connection plugs into solenoid.
D	Connection plugs into back of slave panel for button controls.
E	PE wires attach to green grounding screw on backplate of control panel near disconnect.
F	1/2" Air Line

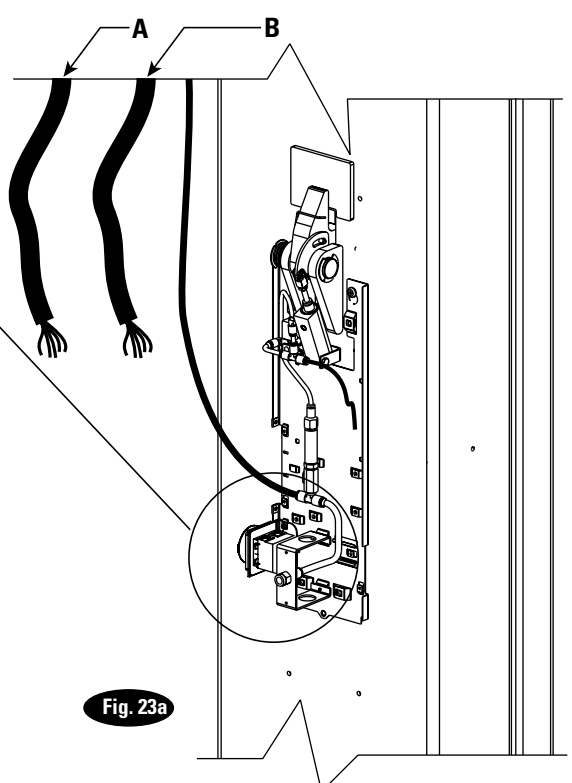
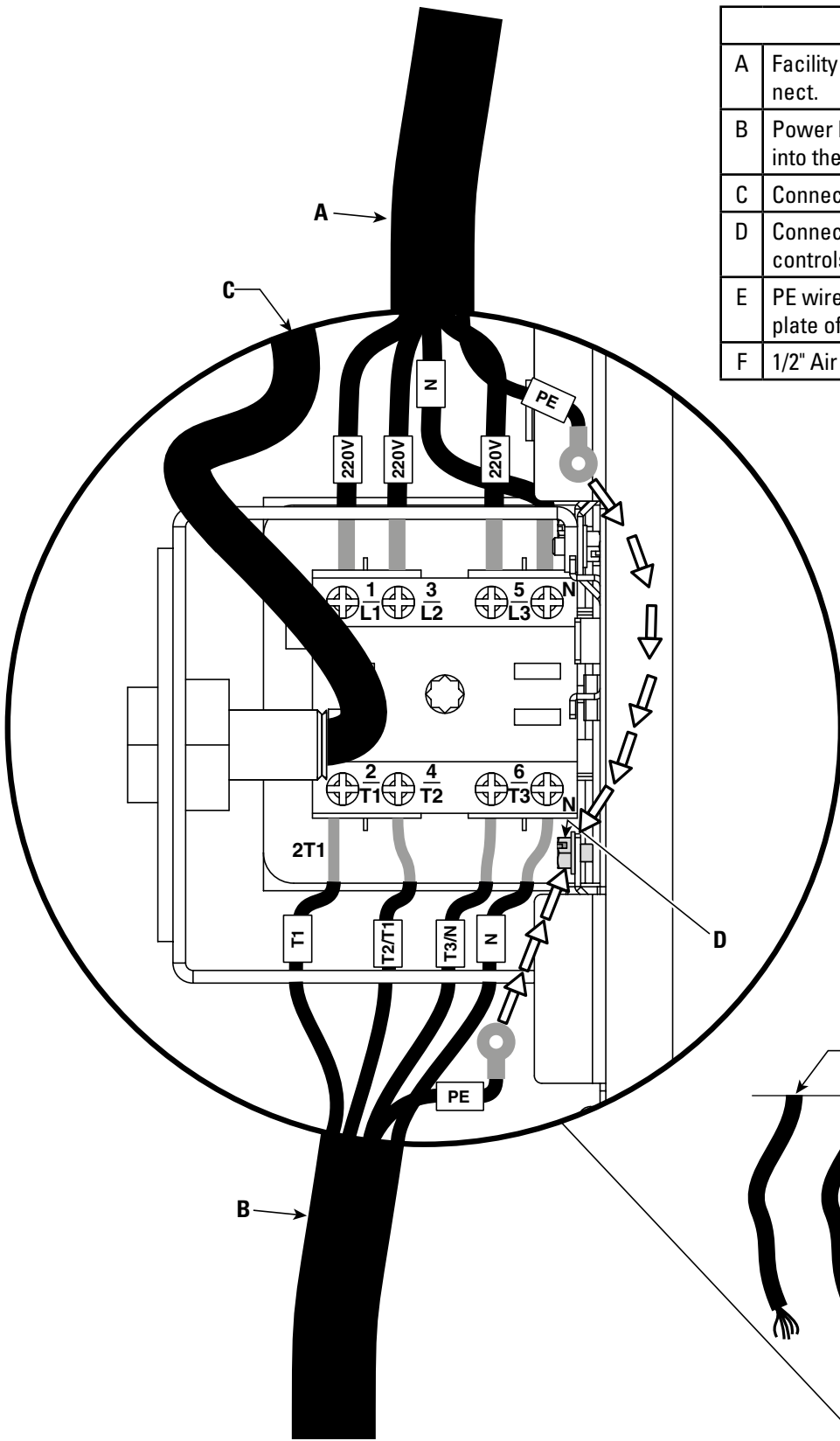


Fig. 23a

### 12-5. Electrical For E Series Lifts:

Have a certified electrician run power supply to slave side disconnect, Fig. 23a for three phase. Size wire for 25 amp circuit. See Motor Operating Data Table.

**IMPORTANT** Use separate circuit for each power supply. Protect each circuit with time delay fuse or circuit breaker. For single phase 230V, use 20 amp fuse. For three phase 400V, use 10 amp fuse. All wiring must comply to all local electrical codes. Wire motor according to wiring diagram provided on page 22.

**IMPORTANT** As with all electronic equipment, the inbay control modules can be affected by voltage irregularities. It is the lift owner's responsibility to ensure that adequately protected power sources are available for connecting this equipment.

#### NOTES:

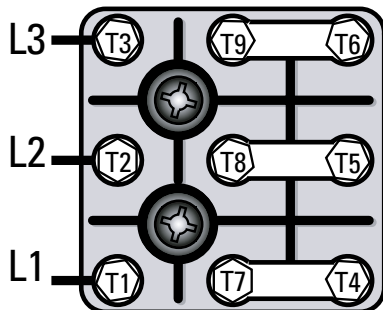
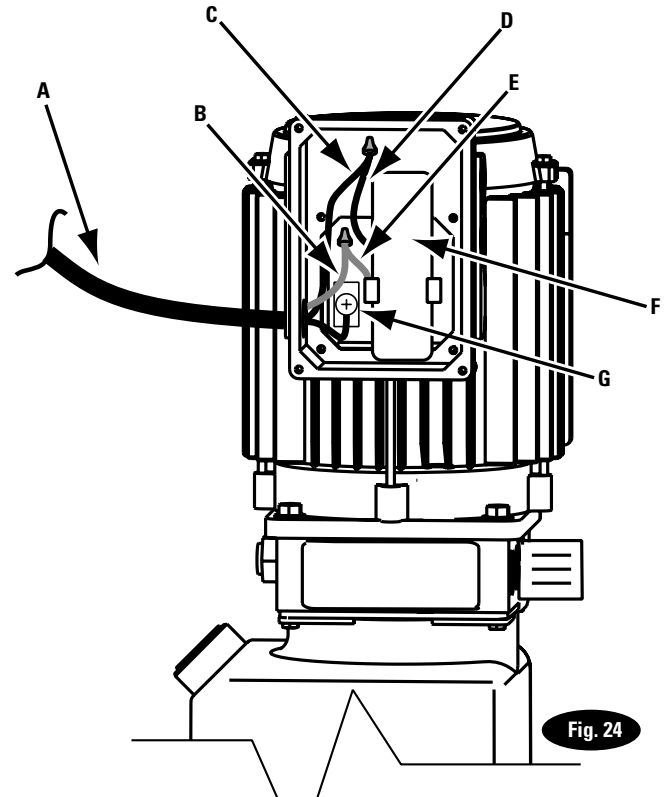
1. Unit not suitable for use in unusual conditions. Contact Rotary Lift for moisture and dust environment duty unit.
2. Motor rotation is counter clockwise from top of motor.

MOTOR OPERATING DATA - SINGLE PHASE					
LINE VOLTAGE		CURRENT		POWER	
220 - 240 Volts	50Hz	17A	-	1.5Kw	

MOTOR OPERATING DATA - THREE PHASE					
LINE VOLTAGE		CURRENT		POWER	
400 - 415 Volts	50Hz	4.55A	-	3Kw	

Fig. 18 Single Phase Motor Wiring 220V/50Hz	
A	Connection from Master Control panel.
B	N
C	L1
D	Black Wire
E	White Wire
F	Capacitor
G	Ground Connection



**High Voltage  
440V, 50Hz**

Fig. 24

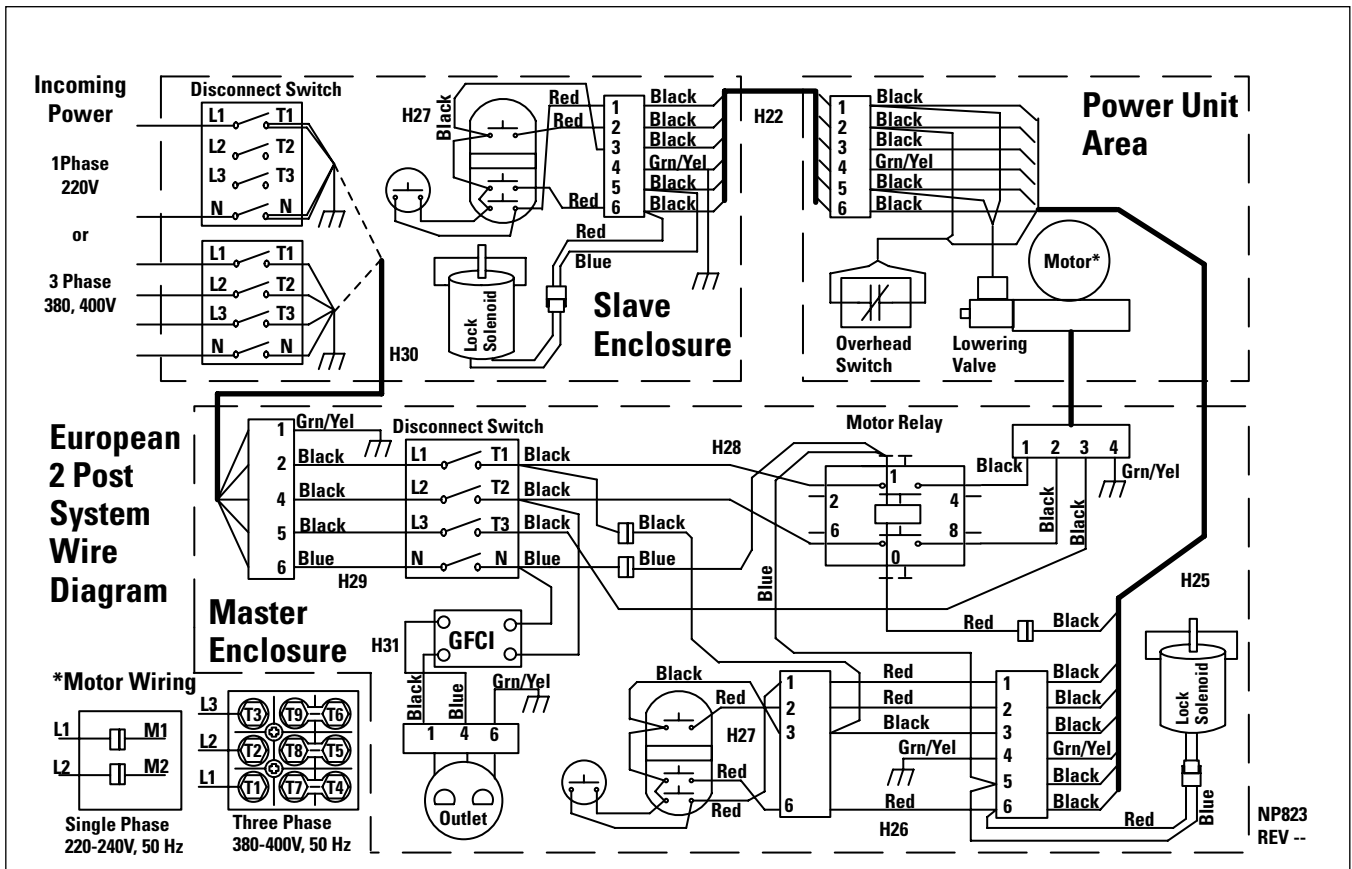


Fig. 25

## 12-6. Installing Gaskets To Master And Slave Enclosures:

**IMPORTANT** These gaskets must be installed to maintain CE certification.

A) To install gasket on master side control, locate the (4) 5/16"-18NCx3/8" BHCS that hold down the black enclosure and loosen them by 3 or 4 turns, Fig. 26. Also loosen the (2) upper and (1) lower 5/16"-18NCx3/8" PHMS that hold the control unit to the column. Fit the gasket behind the master enclosure and tighten down the screws, Fig. 26. Tighten down the mounting screws until the gasket makes a good seal with the column. Do not over tighten.

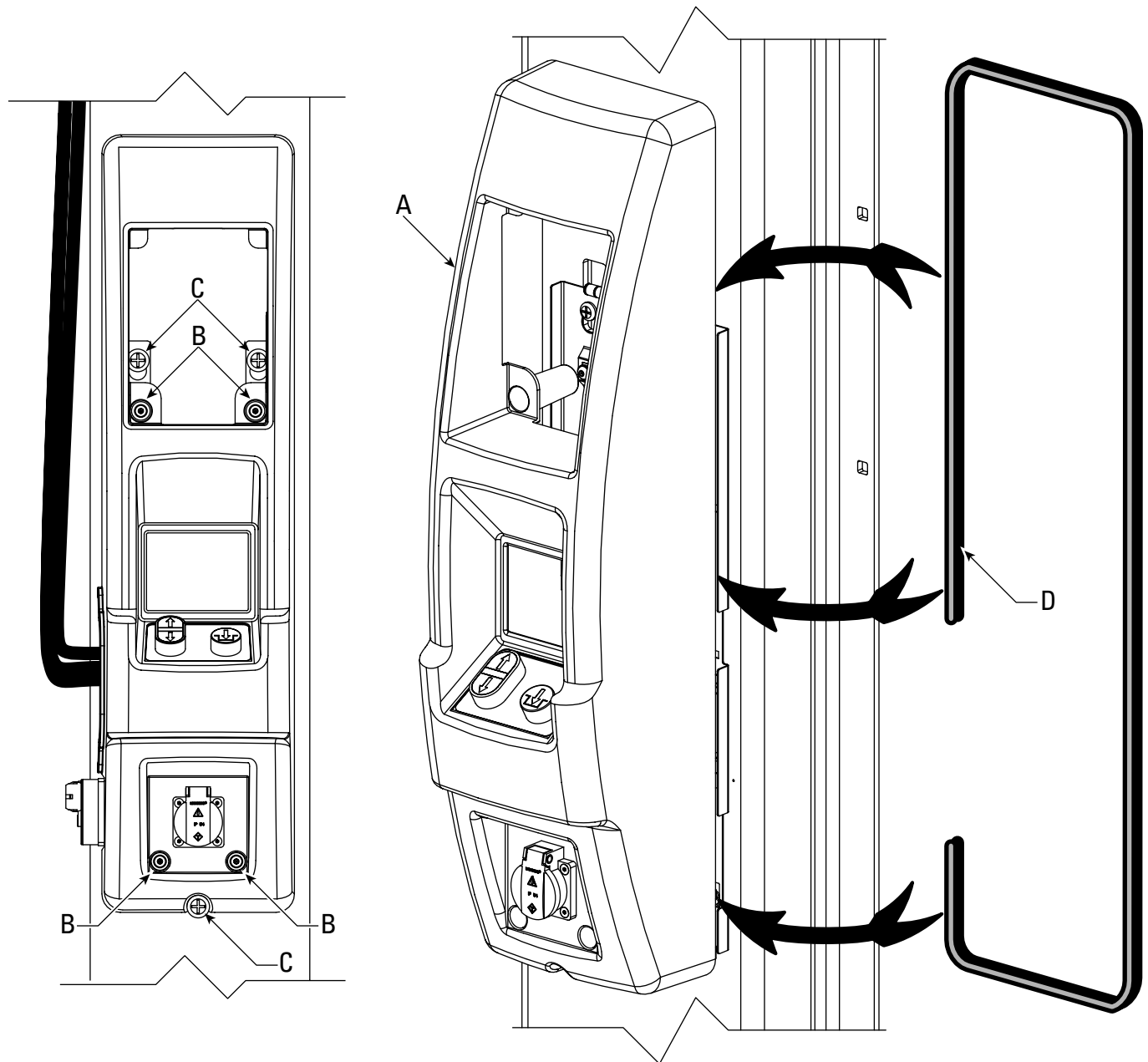


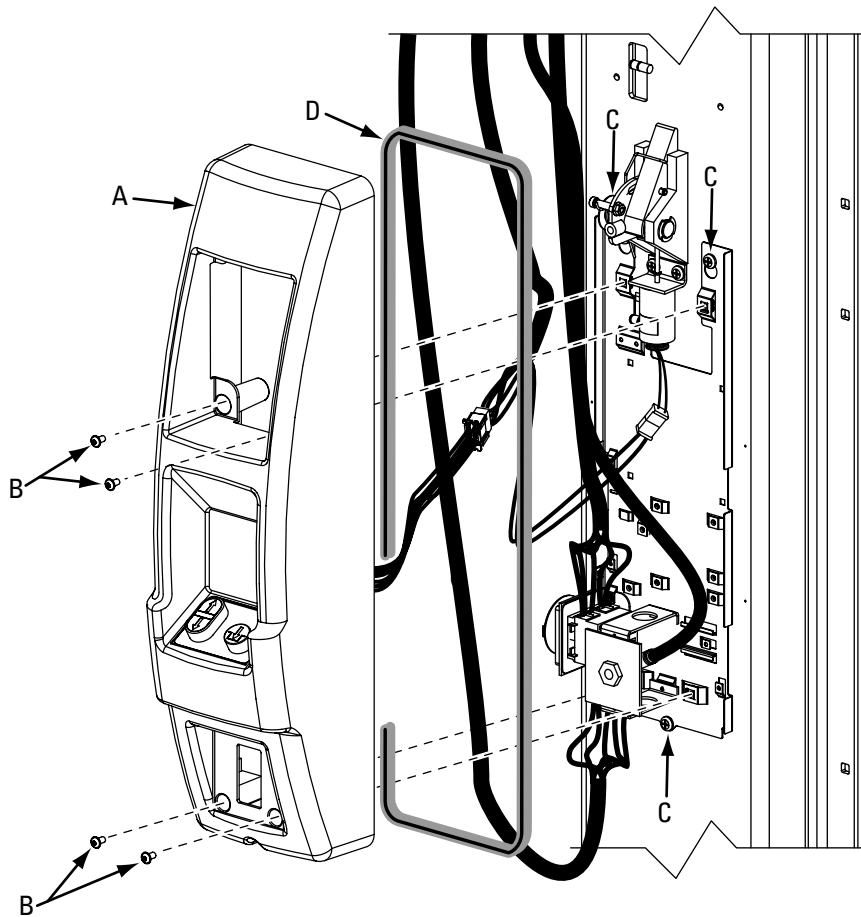
Fig. 26

A	Master Cover
B	(4) 5/16"-18NCx3/8" BHCS
C	(3) 5/16"-18NCx3/8" PHMS
D	Master Cover Gasket

Fig. 26

B) To install gasket on the slave side, loosen the (2) upper and (1) lower 5/16"-18NCx3/8" PHMS that hold the control unit to the column. Fit the gasket behind the black enclosure, make sure to plug in all connections, and reinstall with (4) 5/16"-18NCx3/8" BHCS , Fig. 26a. Tighten down the mounting screws until the gasket makes a good seal with the column. Do not over tighten.

C) Reinstall the access panels.



**Fig. 26a**

Fig. 26a	
A	Slave Cover
B	(4) 5/16"-18NCx3/8" BHCS
C	(3) 5/16"-18NCx3/8" PHMS
D	Slave Cover Gasket

### 12-7. Power Up For E Series Lifts:

Turn disconnect to ON position from the master control panel, Fig. 27.

Note: Lift can only be powered up from the Master Control Side. The Slave Control side only runs the lift.

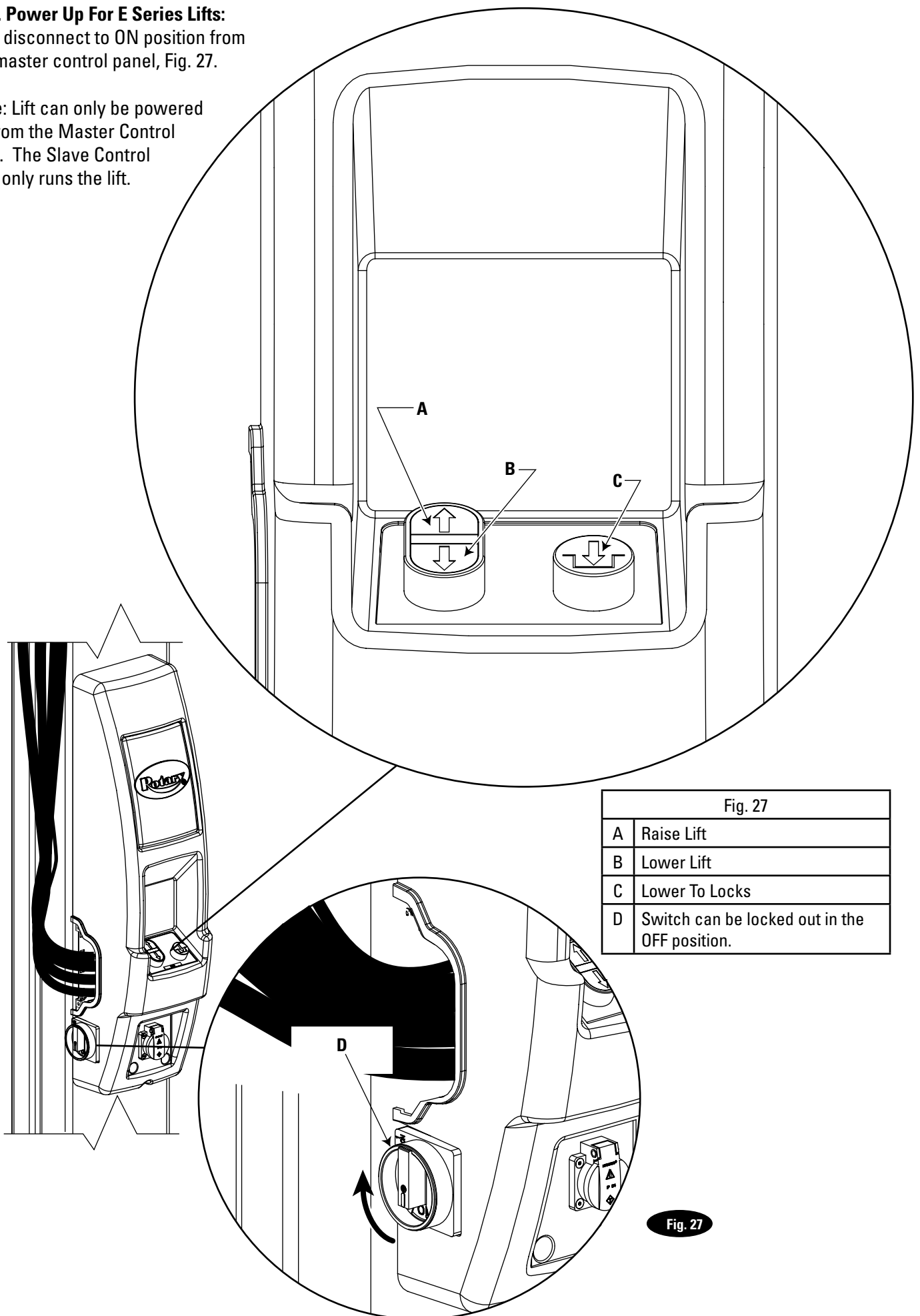


Fig. 27

## 12. Sistema eléctrico para los elevadores de la serie M:

Un electricista cualificado deberá ser el encargado de hacer llegar al motor un suministro de potencia de 400-415 voltios 50 Hz trifásico, Fig. 16. Tamaño de cable para circuito de 15 amp. Consulte la tabla de datos de funcionamiento del motor.

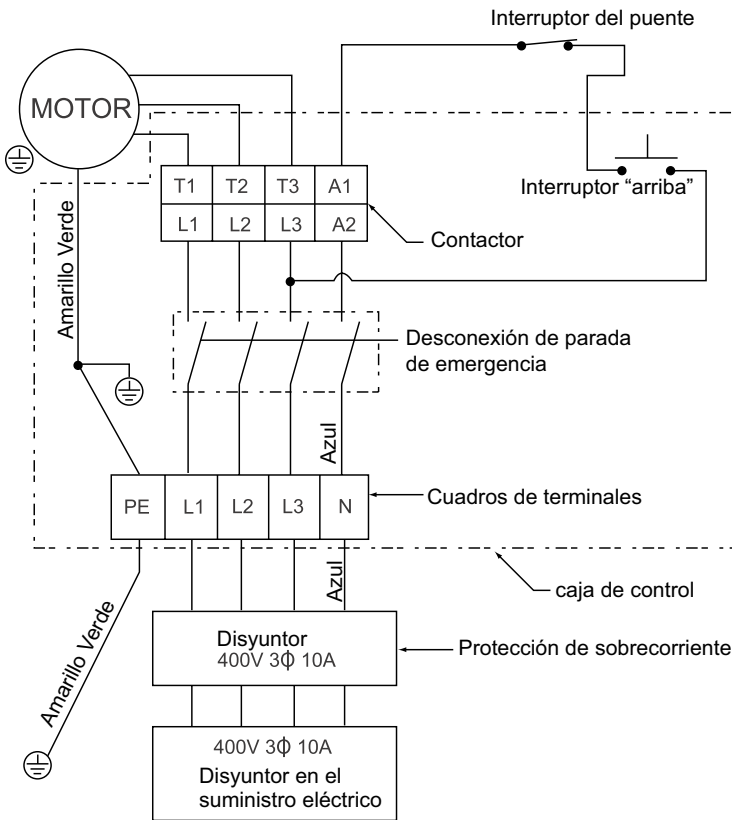


Fig. 28

Notas:

1.) Unidad no apta para ser utilizada en condiciones adversas. Contacte con Rotary para obtener información acerca de una unidad para funcionamiento en ambientes con polvo o húmedos.

2.) El giro del motor se produce en el sentido de las agujas del reloj, visto desde la parte superior del motor.

**IMPORTANTE** Utilice un circuito independiente para cada unidad de potencia. Proteja cada circuito con un disyuntor según los requisitos locales. Disponga de una desconexión por separado (disyuntor de circuito de 10 A, 400V, 3 fases) entre la alimentación de tensión y la unidad de potencia. El cableado debe cumplir con los requisitos eléctricos locales



DATOS DE FUNCIONAMIENTO DEL MOTOR - TRIFÁSICO				
LÍNEA DE TENSIÓN		CORRIENTE	POTENCIA	
400-415 Volts	50 HZ	4.8A	-	2.2 kW



**CAUTION** When bleeding, hold a shop cloth over bleeder screw to buffer the air and fluid while bleeder valve is open.

**13. Oil Filling & Bleeding For M Series Lifts:** System capacity is (14) liters. Use Dexron III or equivalent ATF. Remove fill-breather cap, Fig. 11. Pour in (8) liters of fluid. Start unit, raise lift about 650mm. Open cylinder bleeders approx. 2 turns, Fig. 12. Close when fluid streams. Fully lower lift. Add more fluid until it reaches the fill line.

**CAUTION** If fill-breather is lost or broken, order replacement. Reservoir must be vented.

**13. Oil Filling/Bleeding For E Series Lifts:** Use Dexron III ATF or ISOVG32 Hydraulic Oil. Remove fill-breather cap, Fig. 10. Pour in fluid until it reaches MIN \_\_\_\_\_ mark on the tank. Press  and raise lift about 2 ft. Open cylinder bleeders approx. 2 turns, Fig. 10b. Close bleeders when fluid streams. Press  to fully lower lift. Fill tank until it reaches the MIN \_\_\_\_\_ mark on the tank. Replace fill-breather cap.

**CAUTION** If fill-breather cap is lost or broken, order replacement. Reservoir must be vented.

**14. Wheel Spotting Dishes For Both E And M Series Lifts:** Position wheel spotting dishes as described in Fig. 1. Drill (4) 9.5mm holes 63.5mm deep in concrete floor using holes in wheel spotting dishes as guide. Drive all anchors, provided, into concrete to secure dish.

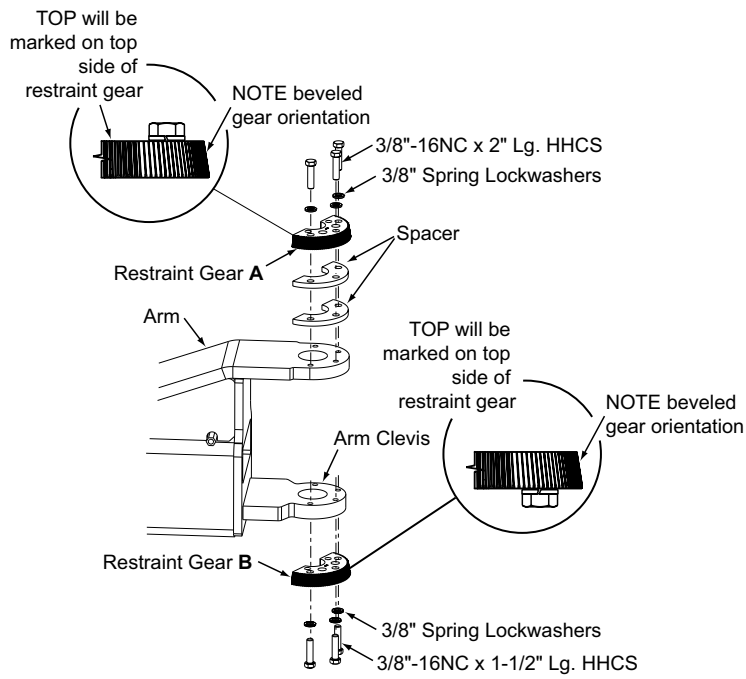
**15. Arm Restraints & Superstructure For Both E And M Series Lifts :** Before installing arms, install arm Restraint Gears as follows making sure Restraint Gear is oriented so that the beveled edge (top side) of the gear teeth is facing upward:

- Install Restraint Gear **A** with (2) Spacers onto upper Arm Clevis with (3) 3/8"-16NC x 2" Lg. HHC Screws and 3/8" Spring Lockwashers as illustrated Fig. 18, but do not tighten.
- Install Restraint Gear **B** with (3) 3/8"-16NC x 1 1/2" Lg. and 3/8" Spring Lockwashers as illustrated Fig. 29, but do not tighten.

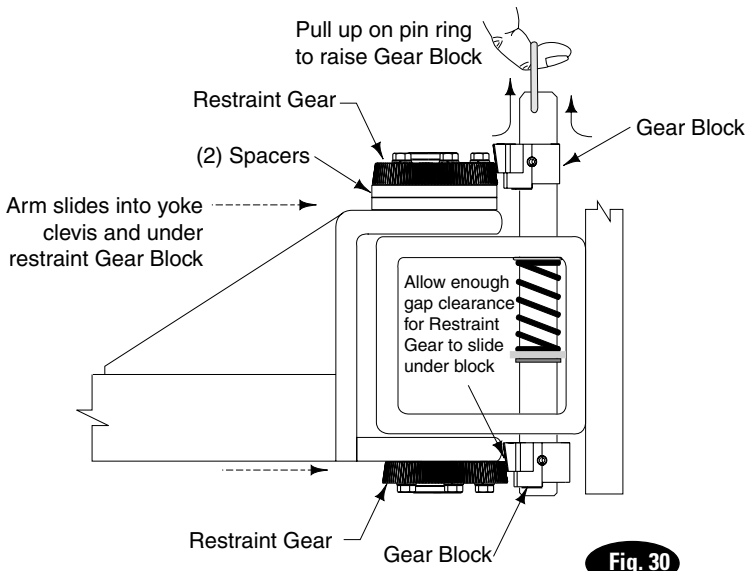
After installing Restraint Gears, raise carriage to a convenient height. Grease Arm Pins and holes with Lithium grease. Raise Gear Block by pulling upward on pin-ring to allow enough clearance for the Restraint Gear and arm to slide over the yoke and under the teeth of the Gear Block (or gear stop), Fig. 30. Install 1 1/2" diameter Arm Pin(s), Fig. 31. Bottom of Restraint Gear **B** holds the Arm Pin in place. Make sure bottom of Gear **B** slides into groove in Arm Pin. Leave 7mm of Spring Pin protruding from hole. Install Arm Guards as shown in Fig. 31.

After installing arm pin, torque the three Restraint Gear bolts to 40.7 - 46.1Nm.. Let the Gear Block down allowing the teeth of the Restraint Gear and Gear Block to mesh together, Fig. 30.

**Note:** To check operation of arm restraints, raise carriage 25mm min. from full down position. Pull up on pin-ring and adjust arms to desired position. To engage restraint, let pin-ring down allowing gear teeth to mesh together. It may be necessary to rotate arm slightly to engage gear teeth.

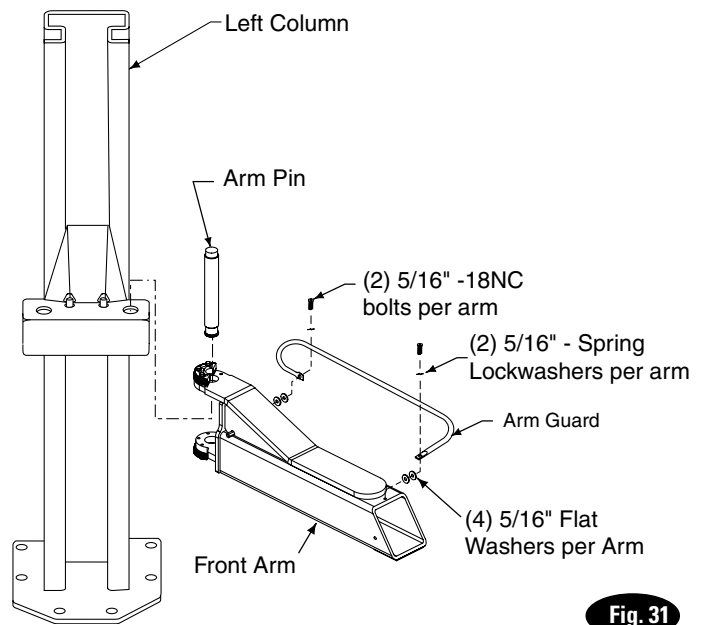


**Fig. 29**



**Fig. 30**

**Note:** Pin, Ring, Spring and Gear Block are pre-assembled at factory. No set up required.

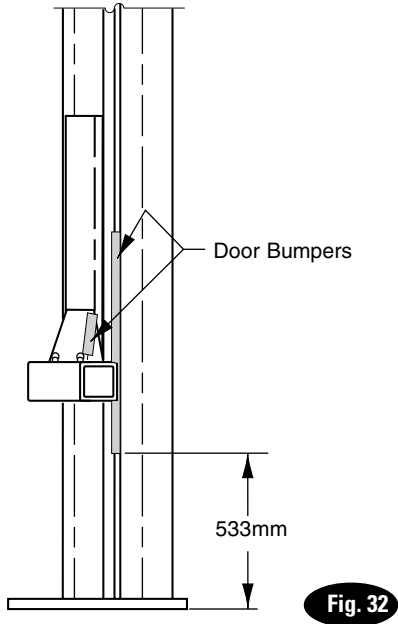


**Fig. 31**

**16. Door Bumper Installation For Both E And M Series Lifts:**

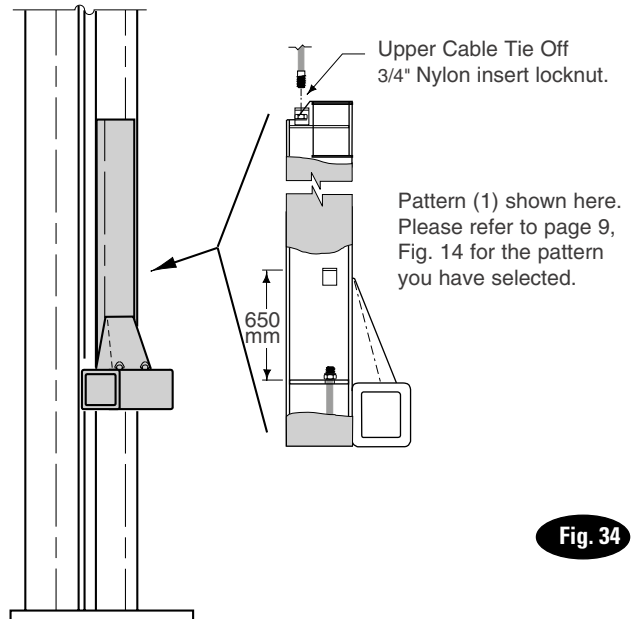
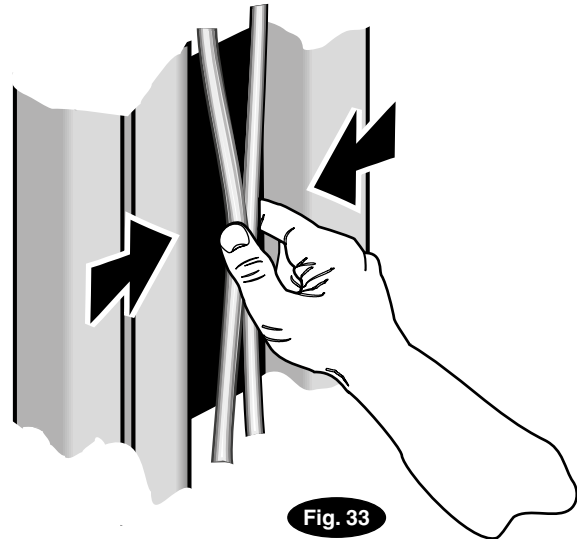
- 1) Press bumpers on column edge and carriage, Fig. 32.

**Note:** Door Bumpers may need to be installed in different areas depending upon type(s) of vehicles used. Fig. 32 is the most recommended.



17. **Pressure Test For M Series Lifts:** Run lift to full rise and keep motor running for 5 seconds. Stop and check all hose connections. Tighten or reseal if required. Repeat air bleeding of cylinders.

18. **Final Adjustments For Both E And M Series Lifts:** Raise lift to check equalizer cable tension. Below carriage, grasp adjacent cables between thumb and forefinger, with about 67N. effort you should just pull the cables together. Adjust at upper tie-offs, Figs. 33 and 34.



**19. For Both E And M Series:**

Check continuity of the protective bonding circuit, perform installation resistance tests, and perform voltage tests according to sections 20.2, 20.3, and 20.4 in EN60204-1:1992.

**20. Testing For M Series Lifts:** Operate lift and assure that push button raises lift when pushed and stops lift when released. Check key switch for cutting power to push-button. Also check that overhead switch stops lift from raising when actuated and that lift regains power when deactivated, Fig. 35.

**20. Testing For E Series:** Check overhead sensor assembly to assure that switch bar is depressing switch plunger sufficiently to actuate the switch. The overhead switch is wired normally open, see appropriate wiring diagram for lift being installed. Lift will not operate until weight of switch bar is depressing switch plunger. Verify that Power Unit stops working when switch bar is raised, and restarts when the bar is released, Fig. 35.

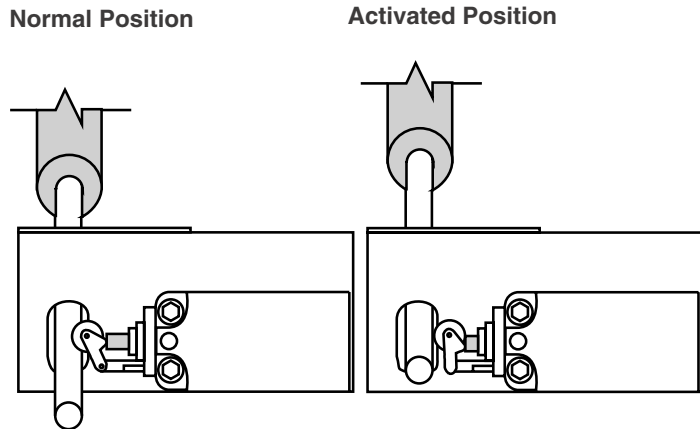


Fig. 35

**21. Pressure Test For M Series Lifts:** Check hydraulic pressure on the power unit. The maximum relief is not to exceed 17.2 N/mm, Fig. 36.

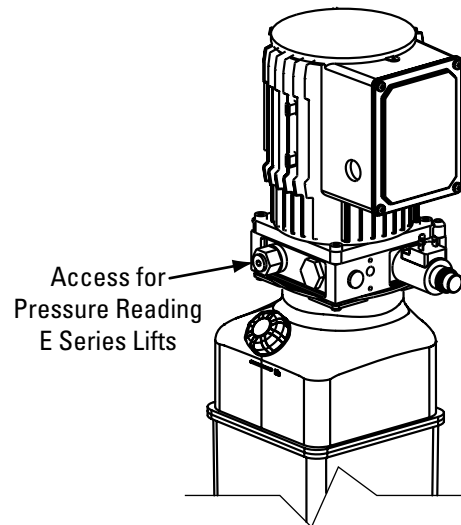
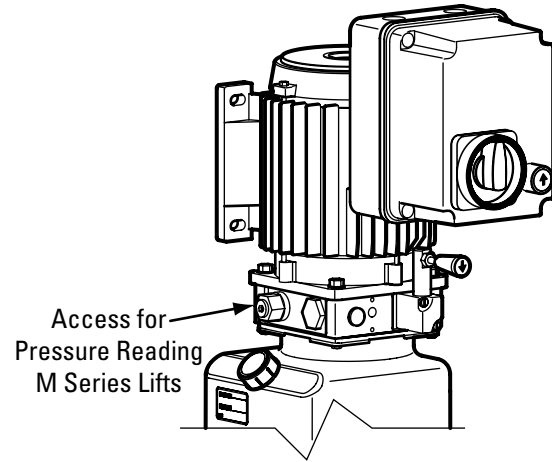


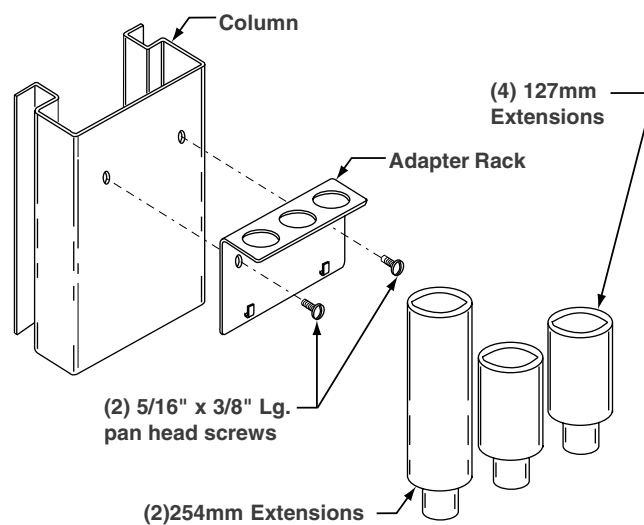
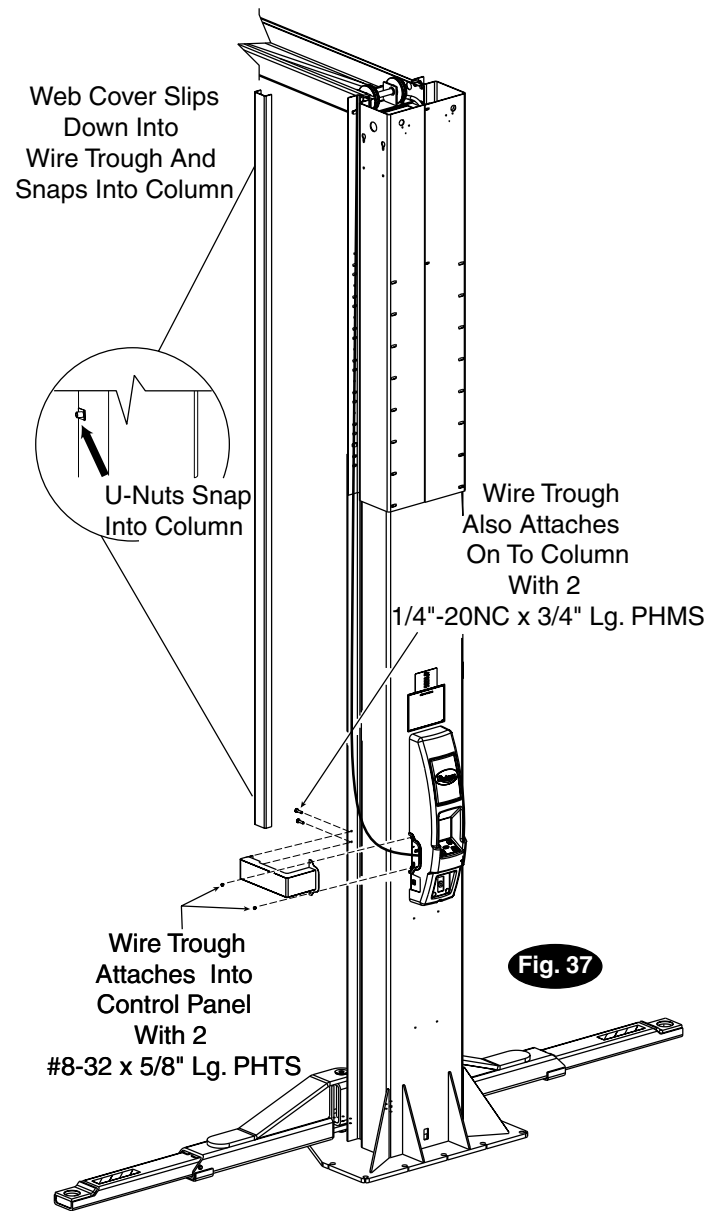
Fig. 36

## 22. Web covering and wire trough placement for E Series

**Lifts:** Start by wire tying all the wires and hoses neatly and out of the way of the cables. Take one of the wire troughs and attach it to one of the control panels with two #8-32NC x 5/8" Lg. PHTS and two 1/4"-20NC x 3/4" Lg. PHMS, Fig 37. Slide web cover down into the wire trough and snap into column.

## 23. Installing Adapter Racks For E And M Series Lifts:

Install adapter racks to columns. The holes are located approximately 537mm from the bottom of the column base plates, Fig. 38.



**Fig. 38**

# NOTES

# NOTES

Installer: **Please return this booklet to literature package, and give to lift owner/operator.**

*Thank You*

**Trained Operators and Regular Maintenance Ensures Satisfactory Performance of Your Rotary Lift.**

**Contact Your Nearest Authorized Rotary Parts Distributor for Genuine Rotary Replacement Parts. See Literature Package for Parts Breakdown.**